

 **PLUSWINCH™**

The REID **PLUS** WINCH is a 1100lb manual goods winch, designed to work in the same challenging environments as our Davit and Gantry range, where reliability and safety are key.

The PlusWinch is ideal for demanding applications where operators need the precision and convenience of a manual goods winch.

Plus with the new Reid material winch, you get many additional features that help increase productivity and improve ergonomics, making sure you can make light work of lifting and lowering.

Key features

- Up to 500kg* Goods capacity ensures even the most ambitious manual lifts are within the PLUS Winch capacity
- Free spool cable system enables rapid cable deployment and quicker on-site setup
- Built in cable tensioner means consistent cable layering and virtually tangle free cable wraps.
- Variable length handle enables faster lifts at lower loads and increased leverage for higher loads
- Low crank force effort of 15daN means easy lifting no matter the task
- Robust steel body and zinc plated drum to ensure longevity in demanding environments.
- Double cable clasp, ensures the cable is held securely in all situations
- Galvanized & stainless steel* cable in lengths from 10 to 20m, supports different user applications
- Driven by spur-gear mechanism incorporating a load pressure brake

*Stainless steel cable version are only available up to 400Kg capacity.



1000LB
CAPACITY



1 PERSON
ASSEMBLY



SPECIFIED
FOR GOODS
LIFTING

Features & Performance

Accreditations, Certifications & Standards	Galvanized Steel Wire Rope Length		
	32' 9 3/4"	49' 2 1/2"	65' 7 1/2"
EN13157:2004+A1:2009 (EU)	✓	✓	✓
Capacity			
Max Capacity First Layer (lb)	1100	1100	1100
Max Capacity Final Layer (lb)	1050	950	860
Specification			
Crank force first layer (lbf)	34	34	34
Hoisting height per crank revolution	1/10"	1/10"	1/10"
Own Weight (lb)	31	31	31

Accreditations, Certifications & Standards	Stainless Steel Wire Rope Length		
	32' 9 3/4"	49' 2 1/2"	65' 7 1/2"
EN13157:2004+A1:2009 (EU)	✓	✓	✓
Capacity			
Max Capacity First Layer (lb)	880	880	880
Max Capacity Final Layer (lb)	880	880	860
Specification			
Crank force first layer (lbf)	34	34	34
Hoisting height per crank revolution (mm)	1/10"	1/10"	1/10"
Own Weight (lb)	31	31	31

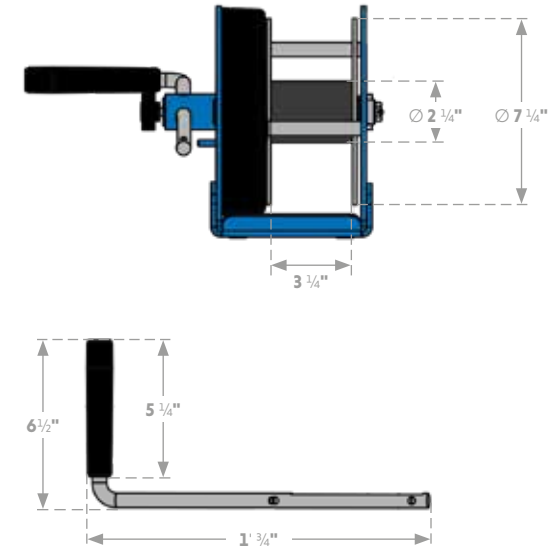
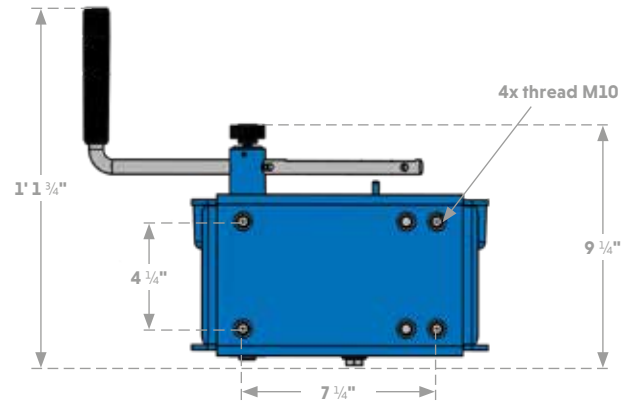
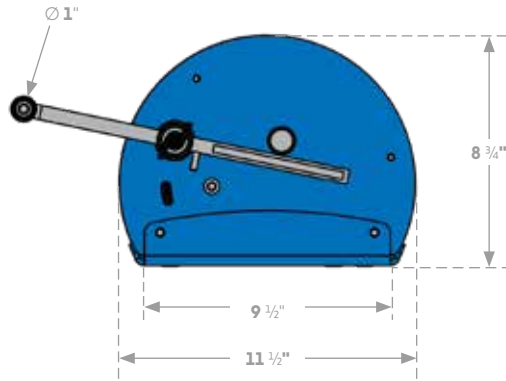

PlusWinch Galvanized Steel Wire Rope				
Product Code	Wire rope Length	Own Weight (lb)	Max Capacity (lb)	
			First Layer	Final layer
US-RLGW50010	32' 9 3/4"	31	1100	1050
US-RLGW50015	49' 2 1/2"	31	1100	950
US-RLGW50020	65' 7 1/2"	31	1100	875

PlusWinch Stainless Steel Wire Rope				
Product Code	Wire rope Length	Own Weight (lb)	Max Capacity (lb)	
			First Layer	Final layer
US-RLGW000010	32' 9 3/4"	31	880	880
US-RLGW000015	49' 2 1/2"	31	880	880
US-RLGW000020	65' 7 1/2"	31	880	860

Ø 3/4" Galvanized Steel Wire Rope			
Wire rope Layer	Wire Rope Capacity per layer	Total Capacity	Max Load (lb)
1	6' 2 3/4"	6' 2 3/4"	1100
2	8' 6 1/2"	14' 9 1/4"	1100
3	10' 10"	25' 7"	1100
4	11' 1 3/4"	36' 9"	1050
5	13' 5 1/2"	50' 2 1/4"	950
6	13' 5 1/2"	63' 7 3/4"	875

Ø 3/4" Stainless Steel Wire Rope			
Wire rope Layer	Wire Rope Capacity per layer	Total Capacity	Max Load (lb)
1	6' 2 3/4"	6' 2 3/4"	880
2	8' 6 1/2"	14' 9 1/4"	880
3	10' 10"	25' 7"	880
4	11' 1 3/4"	36' 9"	880
5	13' 5 1/2"	50' 2 1/4"	880
6	13' 5 1/2"	63' 7 3/4"	860

➤ Brackets for fixing to REID products

Brackets for PlusWinch	
Product Code	Product
US-RAWB010200	T DAVIT [®] , PORTX [®] DAVIT or PORTA DAVIT [®] <small>QUANTUM</small> Column
US-RAWB010203	PORTA DAVIT 500 Backstay
US-RAWB010206	PORTA DAVIT [®] <small>QUANTUM</small> Backstay
US-RAWB010208	PORTA GANTRY [®] Winch column
US-RAWB010209	PORTX [®] DAVIT with deviation
US-RAWB010220	PORTA GANTRY [®] <small>RAPIDE</small>
US-RAWB010225	PORTA GANTRY [®] small or medium trap plate

All information herein is copyright protected by REID Lifting Ltd. All company and product names are Trade Mark and Trade Name protected and all REID Product IPR is protected under Patents, Patents Pending and/or Design Rights.

 Printed using environment friendly processes and materials.

REID Lifting Inc
 7900 International Drive,
 Suite 300,
 Bloomington,
 MN 55425

➤ +1-(888)-721-6411
 ➤ info@reidlifting.com
 ➤ us.reidlifting.com