

# FOLDABLE/NESTABLE ROLLER CONTAINERS - ROL-1834-3

APPROX WEIGHT: 134.32 lbs.  
DOES NOT INCLUDE WEIGHT OF POWER OR PACKAGING!!!

\*\*\* ANY ADDITIONS, DELETIONS, OR OMISSIONS MUST BE CORRECTED ON THIS DRAWING AS THIS DRAWING WILL BE CONSIDERED ALL INCLUSIVE \*\*\*

ALL GRAPHICS PROVIDED ARE FOR REFERENCE ONLY. IF CERTAIN DIMENSIONS ARE CRITICAL PLEASE VERIFY THOSE DIMENSIONS WITH YOUR SALESPERSON

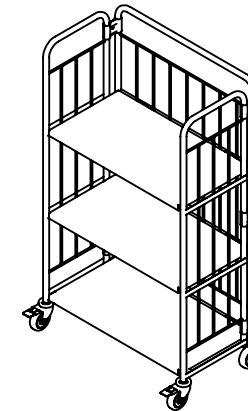
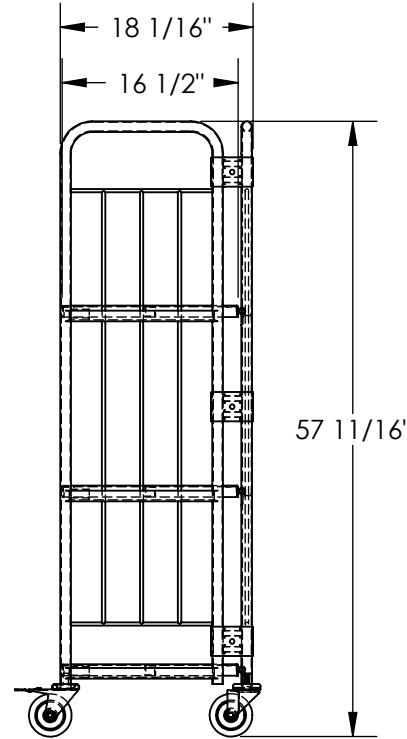
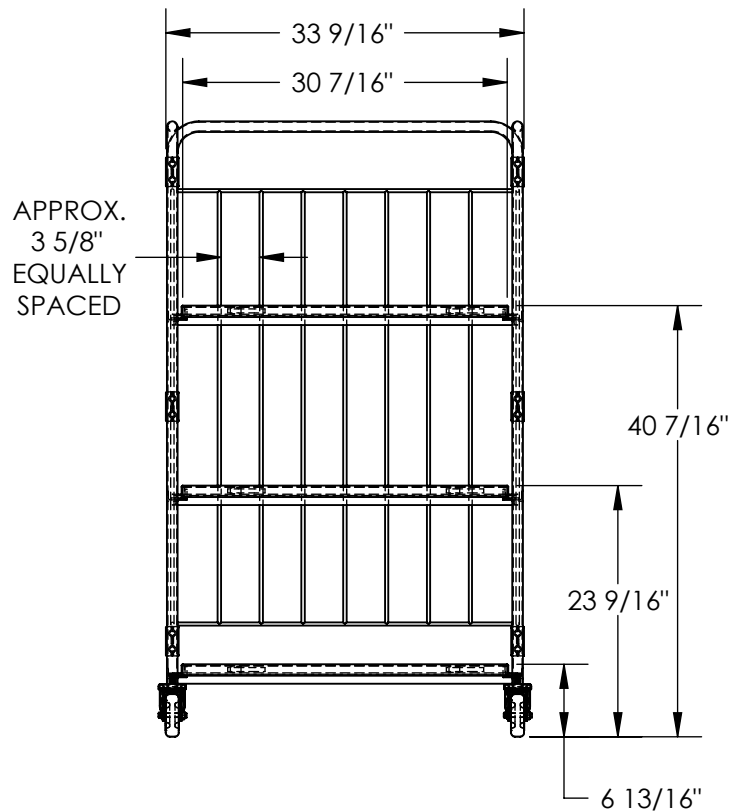

OPEN

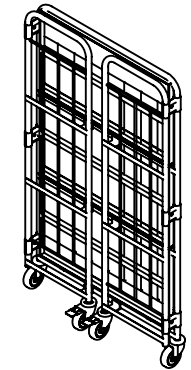

COLLAPSED

DIMENSION TOLERANCE ± 1/4"

## STANDARD FEATURES

- MODEL NUMBER IS ROL-1834-3
- OVERALL WIDTH IS 33 9/16"
- USABLE WIDTH IS 30 7/16"
- OVERALL DEPTH IS 18 1/16"
- USABLE DEPTH IS 16 1/2"
- OVERALL HEIGHT IS 57 11/16"
- MAX CAPACITY IS 990 LBS.;
- 330 LBS PER SHELF
- FOUR SWIVEL CASTERS,
- TWO WITH SIDE BRAKES
- UNIT IS COLLAPSABLE
- FOR EASY STORAGE
- TOUGH BAKED IN POWDER COAT BLUE FINISH

## SPECIAL FEATURES

NONE

APPROVAL

I, THE UNDERSIGNED, AGREE THAT THE PRODUCT AS REPRESENTED SATISFIES DESIGN AND DIMENSION REQUIREMENTS. I ALSO ACKNOWLEDGE MY DUTY TO CONFIRM PRODUCT AND INSTALLATION COMPLIANCE WITH ALL APPLICABLE FEDERAL, STATE AND LOCAL REGULATIONS AND STANDARDS.

**UNITS REQUIRING APPROVAL DRAWINGS OR MODIFIED ARE NON-RETURNABLE**

As drawn       As marked

Signed: \_\_\_\_\_ Date: \_\_\_\_\_

Printed Name: \_\_\_\_\_

LEAD TIME WILL START UPON RECEIPT OF SIGNED APPROVAL DRAWING

DISTRIBUTOR'S NAME:		P.O.#
VESTIL MANUFACTURING		X
DRAWN BY: JB		W.O.#
DATE: 07/01/09		X
REFERENCE: X	SCALE: 1:18	SALES: X
QUOTED LEAD TIME: X	QUOTE #	FILE NAME:
	X	16-007-214