

ROTARY LIFT, LO-TEMP W/ SAFETY LOCK, THERMAL ZINC COATED (416000C)

Cage Code: 65059 | Drawing No: S416000C | Revision: F | Sheet: 1 of 1

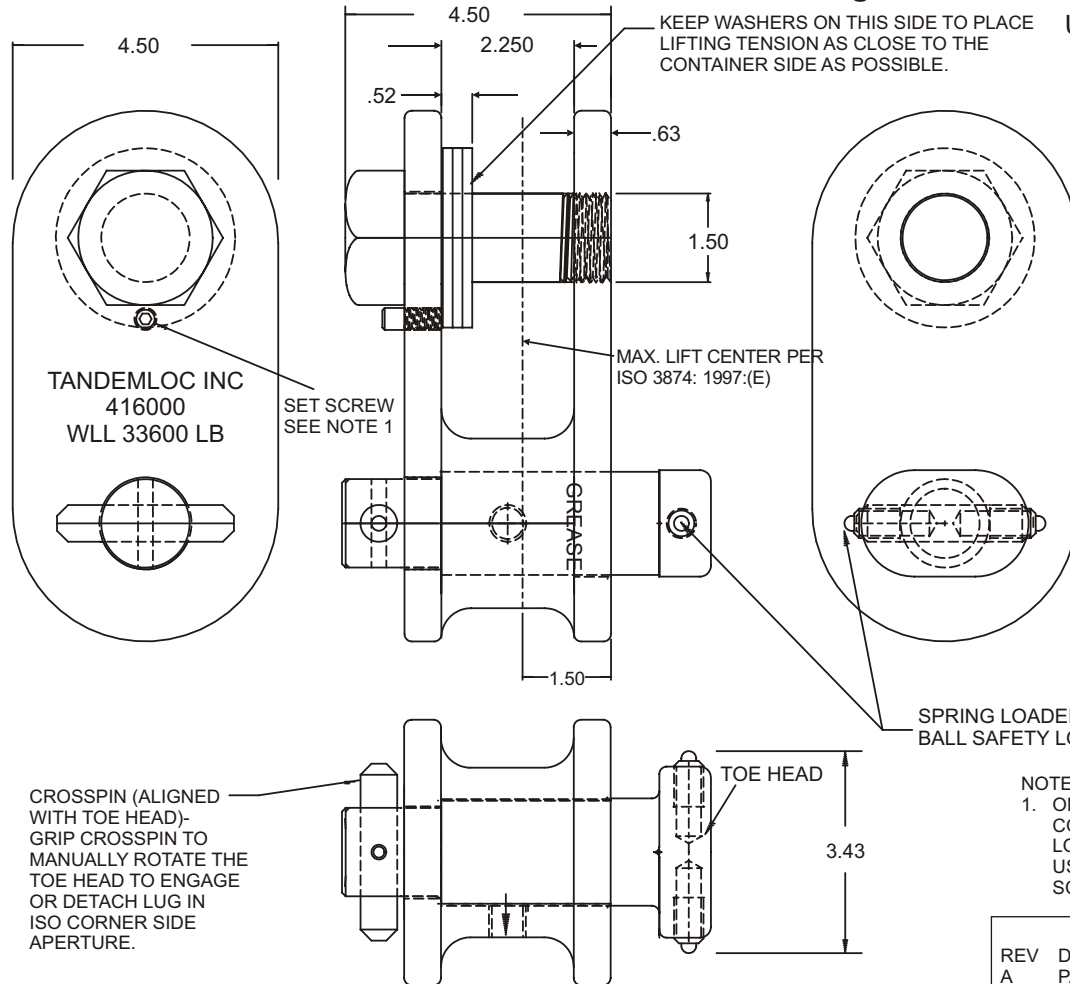

WORK LOAD LIMIT (WLL): 33,600 LB.P
ROOF TESTED TO 2X WLL.

416000C-LSTZ LUG, ROTARY LIFT WITH SAFETY LOCK,
LO-TEMP TYPE, THERMAL ZINC COATED, WEIGHT 22.3 LB

To avoid lifter failure, potential death and property damage, Never Exceed WLL (Working Load Limit)

This document contains the proprietary information of Tandemloc, Inc. and your access and use shall be, and is at all times, pursuant to and limited by the Tandemloc, Inc. Terms of Use.

You shall not, and shall not encourage, assist, or authorize another party to copy, distribute, publically display, modify, reverse engineer, decompile, or take any other action to reproduce or replicate this document or the information contained herein. © Copyright 2011 by Tandemloc, Inc.

Dimensions are subject to manufacturing tolerance and change.

UNLESS OTHERWISE SPECIFIED, DIMENSIONS ARE IN INCHES

USE:

USE THE ROTARY LIFT LUG TO CONNECT LIFTING SLINGS TO THE BOTTOM SIDE APERTURES IN ISO 668 TYPE FREIGHT CONTAINER CORNER FITTINGS (ISO 1161). WHEN TOE OF THE LUG IS INSERTED INTO THE APERTURE, IT IS ROTATED MANUALLY, USING THE CROSSPIN, TO A LOCK POSITION 90° OFFSET FROM ITS ENTRY POSITION. WHEN THE SLING IS LIFTED, THE FLAT SIDES OF THE TOE HEAD BEAR UP ONTO THE INTERNAL "CEILING" WALL OF THE CORNER FITTING AND ARE THUS HELD IN THE LOCK POSITION DURING THE LIFT. BECAUSE THE BODY OF THE ROTARY LUG FREELY ROTATES ABOUT THE TOE HEAD, THE LIFT SLING LEG CAN ASSUME ANY ANGLE FROM BETWEEN 30° TO 90° FROM HORIZONTAL WITHOUT CHANGING THE INTERNAL BEARING OF THE TOE HEAD INSIDE THE CORNER.

THE -LSTZ ASSEMBLY HAS AN ADDITIONAL SAFETY FEATURE TO HELP PREVENT THE LUG FROM ACCIDENTAL DISLODGEMENT, UNDER UNSTABLE DYNAMIC CONDITIONS, WHERE IT IS NOT PRACTICAL TO HAVE PERSONNEL STANDING BY TO INSURE THAT THE 90° INTERLOCK OF THE TOE IN THE CORNER FITTING IS MAINTAINED PRIOR TO THE FINAL LIFTING.

TO INSERT THE -LSTZ ASSEM., ALIGN THE TOE HEAD FOR ENTRY INTO THE APERTURE IN THE CORNER FITTING. TILT THE BODY BACK SLIGHTLY AND LAY THE BOTTOM BALL LOCK INSIDE THE APERTURE, DEPRESSING IT AS THE BODY IS TILTED UP AGAINST THE SIDE OF THE CORNER AND ALLOWING THE TOP BALL LOCK TO ENTER THE APERTURE. PUSH AGAINST THE BODY & MANUALLY TURN THE TOE FROM THE OPPOSITE END, USING THE CROSSPIN TO GRIP AND TURN IT. SINCE THE CROSSPIN IS IN THE SAME PLANE AS THE TOE HEAD YOU WILL SEE WHEN THE 90° INTERLOCK IS ACHIEVED. ONCE INTERLOCKED, THE BALL LOCKS EXPAND TO RESIST DISLODGING. TO REMOVE, REVERSE THE PROCEDURE.

FOR USE IN TEMPERATURES FROM 120° TO MINUS 40° F.

THE 416000C-LSTZW IS THE EXACT SAME AS THE 416000C-LSTZ EXCEPT THE BODY IS WELDED INSTEAD OF CAST.

SPRING LOADED
BALL SAFETY LOCKS

NOTE:

- ONCE THE ROTARY LIFT LUG IS CONNECTED TO A LIFT PENDANT, LOCKTITE SOLUTION SHOULD BE USED ON THREADS OF THE SET SCREW TO PREVENT UNSCREWING.

REVISIONS				
REV	DESCRIPTION	DATE	APPROVED	
A	PART NO. 416000B-YPA WAS 416000C-YPA	4/15/97	MD	
B	ADDED ISO 3874 DATA & DIMS.	4/24/03	MD	
C	ADDED NOTE 1 & CHANGED TOE SHAPE	6/18/03	MD	
D	REMOVED WASHER, -STZ WAS -SPA	7/09/04	MD	
E	PART NO. DASH -LSTZ WAS -SPA. / LO-TEMP ADDED	3/01/05	MD	
F	ADDED NOTE ABOUT -LSTZW BEING WELDED INSTEAD OF CAST	6/07/12	DAH	



Email: info@tandemloc.com • www.tandemloc.com
824 Highway 101 • Havelock, NC 28532
TEL: 1.800.258.7324 (252.447.7155)
FAX: 1.800.892.3273 (252.447.5502)

Tandemloc designs, manufactures and tests lifting, securing and mobilizing components for all industries. See our website for details and important safety information.
Read all safety labels and instructions prior to use. Product to be used by qualified personnel only.