

REVISIONS			
REV	DESCRIPTION	DATE	APPROVED

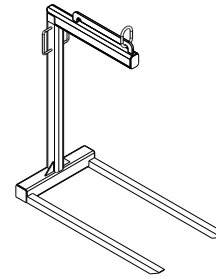

This document contains the proprietary information of Tandemloc, Inc. and your access and use shall be, and is at all times, pursuant to and limited by the Tandemloc, Inc. Terms of Use. You shall not, and shall not encourage, assist, or authorize another party to copy, distribute, publicly display, modify, reverse engineer, decompile, or take any other action to reproduce this document or the information contained herein.

©2019 by Tandemloc, Inc.  
Dimensions are subject to manufacturing tolerance and change.

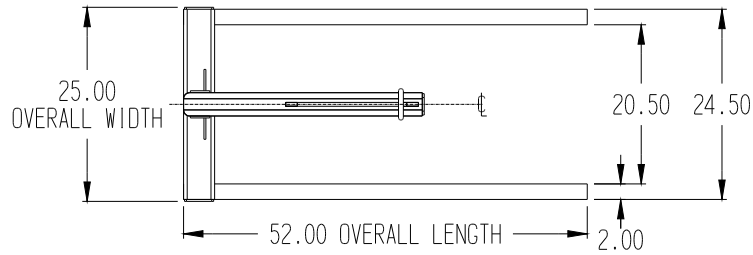
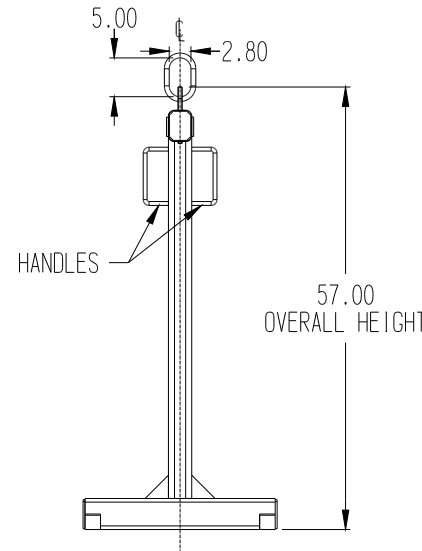
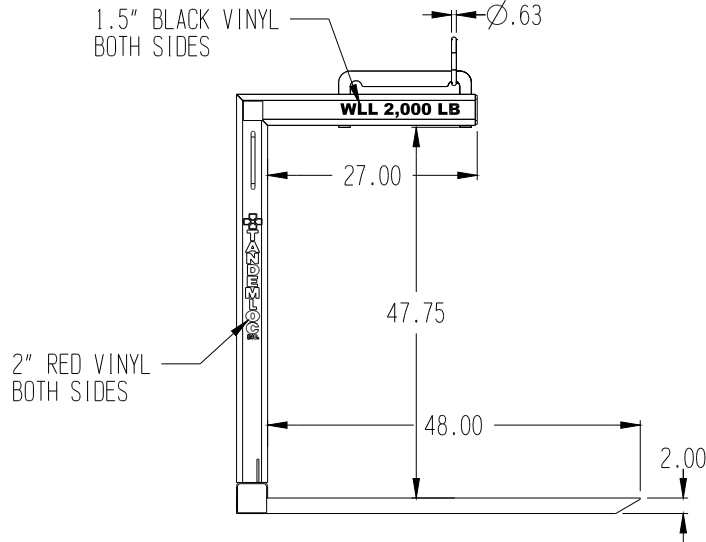

- NOTES:
- PART NO.: AN17A02-00A-PA, LIGHT WEIGHT FIXED FORK PALLET LIFTER
  - WLL: 2,000 LB.
  - PROOF TESTED TO 125% (2,500 LB.) AND CERTIFIED
  - STANDARD SPECIFICATION # EAD21000A APPLIES
  - FINISH: SANDBLAST, PRIME AND PAINT SAFETY YELLOW
  - CALCULATED WEIGHT: 274 LB.
  - DESIGNED AND MANUFACTURED TO MEET OR EXCEED ASME B30.20 AND BTH-1, DESIGN CATEGORY B, SERVICE CLASS 0.

**\*\* DO NOT SIGN IF CHANGES ARE REQUIRED \*\***

**CUSTOMER APPROVAL:** \_\_\_\_\_

**DATE:** \_\_\_\_\_

<input checked="" type="checkbox"/> "X" DENOTES APPLICABLE DATA UNLESS OTHERWISE NOTED. DIMENSIONS ARE IN INCHES & TOLERANCES ARE: .XX ±.00 .XXX ±.0007 .XXX ±.03	<input type="checkbox"/> "Y" DENOTES APPLICABLE DATA LOST WAX CASTING TOL. IS: 0 TO 4" ±.030, 4.01" TO 7" ±.038" 7.01" TO 10.5" ±.045" OVER 10.5" ±.052"		
		TITLE <b>AN17A02-00A-PA LIGHT WEIGHT FIXED FORK PALLET LIFTER</b>	
THIS DOCUMENT CONTAINS DATA WHICH IS EITHER PATENTED, PATENT PENDING OR IS THE PROPERTY OF TANDEMLOC, INC. DISCLOSURE, OR COPYING WITHOUT THE WRITTEN AUTHORIZATION OF TANDEMLOC, INC. IS EXPRESSLY PROHIBITED.		APPROVALS DRAWN: <b>DAH</b> DATE: <b>05-10-12</b>	SCALE: _____
SIZE: <b>D</b> CASE CODE: <b>65059</b>		DWG NO.: <b>SAN17A02</b>	REV: <b>-</b>
SHEET 1 OF 1			