

AUTO-HITE CART - SCSC-1000-4848

APPROX WEIGHT: 401.95 lbs.
 DOES NOT INCLUDE WEIGHT OF POWER OR PACKAGING!!!

*** ANY ADDITIONS, DELETIONS, OR OMISSIONS MUST BE CORRECTED ON THIS DRAWING AS THIS DRAWING WILL BE CONSIDERED ALL INCLUSIVE ***

ALL GRAPHICS PROVIDED ARE FOR REFERENCE ONLY. IF CERTAIN DIMENSIONS ARE CRITICAL PLEASE VERIFY THOSE DIMENSIONS WITH YOUR SALESPERSON

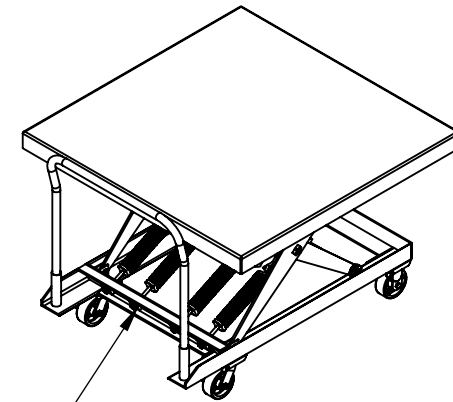
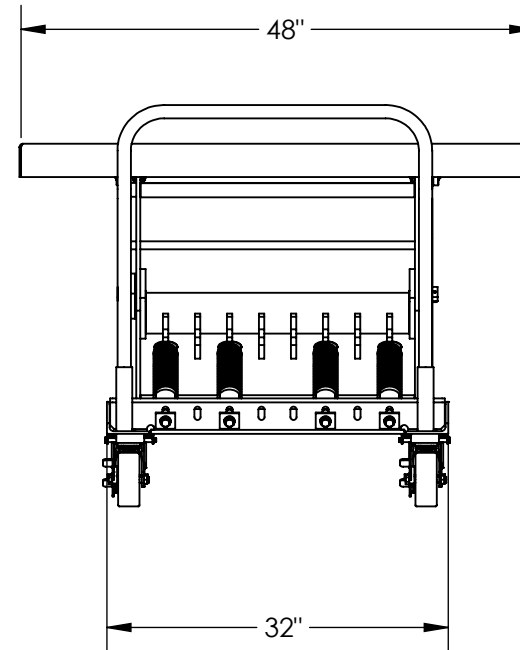
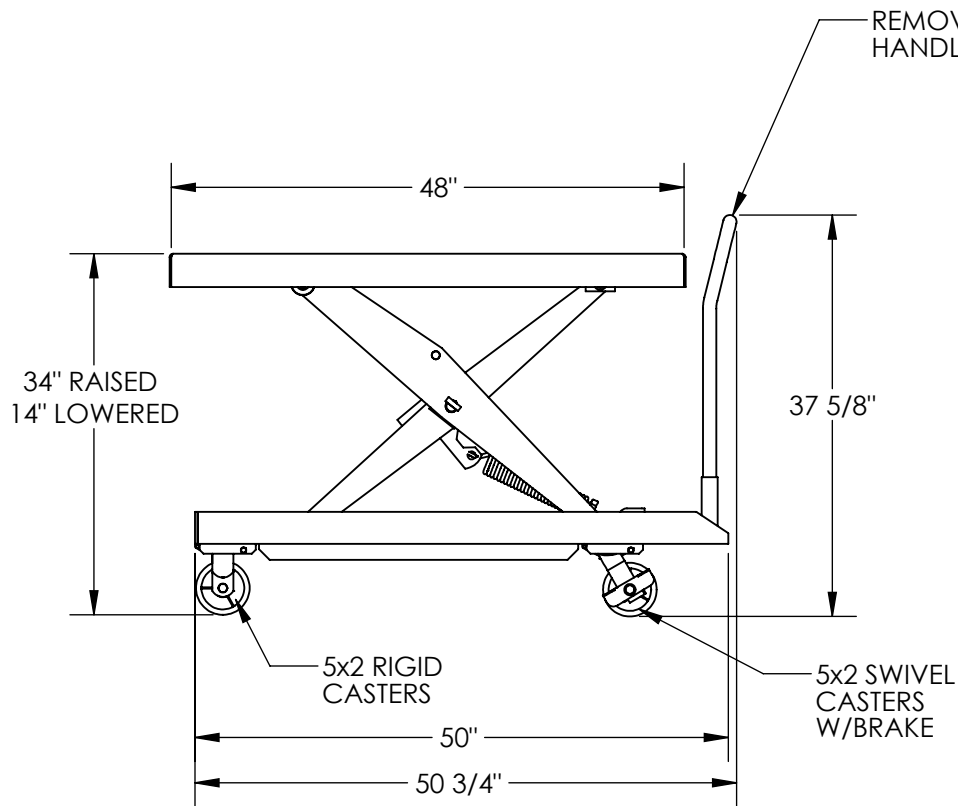

DIMENSION TOLERANCE ± 1/4"

STANDARD FEATURES

- MODEL NUMBER IS SCSC-1000-4848
- MAX CAPACITY IS 1,000 LBS
- DECK SIZE: 48" W x 48" LG
- FRAME SIZE: 32" W x 50" LG
- RAISED HEIGHT: 34"
- LOWERED HEIGHT: 14"
- TRAVEL: 20"
- 5x2 CASTERS (2 SWIVEL W/BRAKE, 2 RIGID)
- SPRING RATE: 50 LBS/IN
- # OF SPRINGS: 4
- DURABLE LIQUID PAINT BLUE FINISH

SPECIAL FEATURES

NONE

APPROVAL

I, THE UNDERSIGNED, AGREE THAT THE PRODUCT AS REPRESENTED SATISFIES DESIGN AND DIMENSION REQUIREMENTS. I ALSO ACKNOWLEDGE MY DUTY TO CONFIRM PRODUCT AND INSTALLATION COMPLIANCE WITH ALL APPLICABLE FEDERAL, STATE AND LOCAL REGULATIONS AND STANDARDS.
UNITS REQUIRING APPROVAL DRAWINGS OR MODIFIED ARE NON-RETURNABLE
 As drawn As marked

Signed: _____ Date: _____

Printed Name: _____

LEAD TIME WILL START UPON RECEIPT OF SIGNED APPROVAL DRAWING

DISTRIBUTOR'S NAME:		P.O.#
VESTIL MANUFACTURING		X
W.O.#		X
DRAWN BY: MVG	DATE: 07/23/13	SALES: X
REFERENCE: X	SCALE: 1:18	FILE NAME:
QUOTED LEAD TIME: X	QUOTE # X	01-007-027