

AUTO-HITE CART - SCSC-500-2040

APPROX WEIGHT: 267.27 lbs.
DOES NOT INCLUDE WEIGHT OF POWER OR PACKAGING!!!

*** ANY ADDITIONS, DELETIONS, OR OMISSIONS MUST BE CORRECTED ON THIS DRAWING AS THIS DRAWING WILL BE CONSIDERED ALL INCLUSIVE ***

ALL GRAPHICS PROVIDED ARE FOR REFERENCE ONLY. IF CERTAIN DIMENSIONS ARE CRITICAL PLEASE VERIFY THOSE DIMENSIONS WITH YOUR SALESPERSON

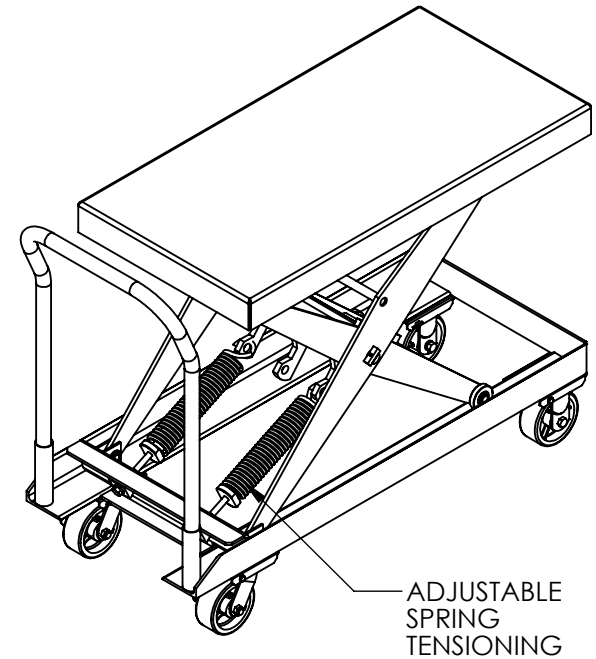
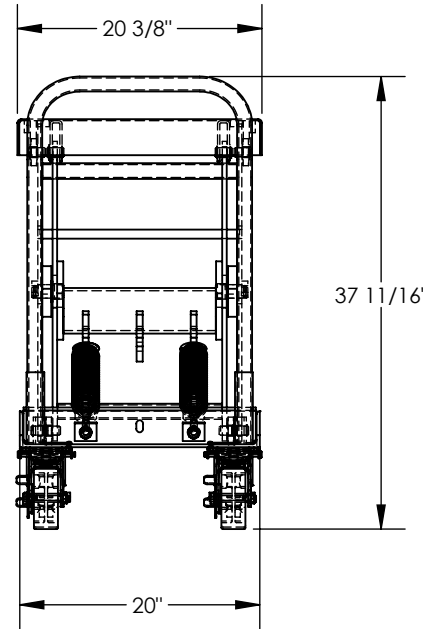
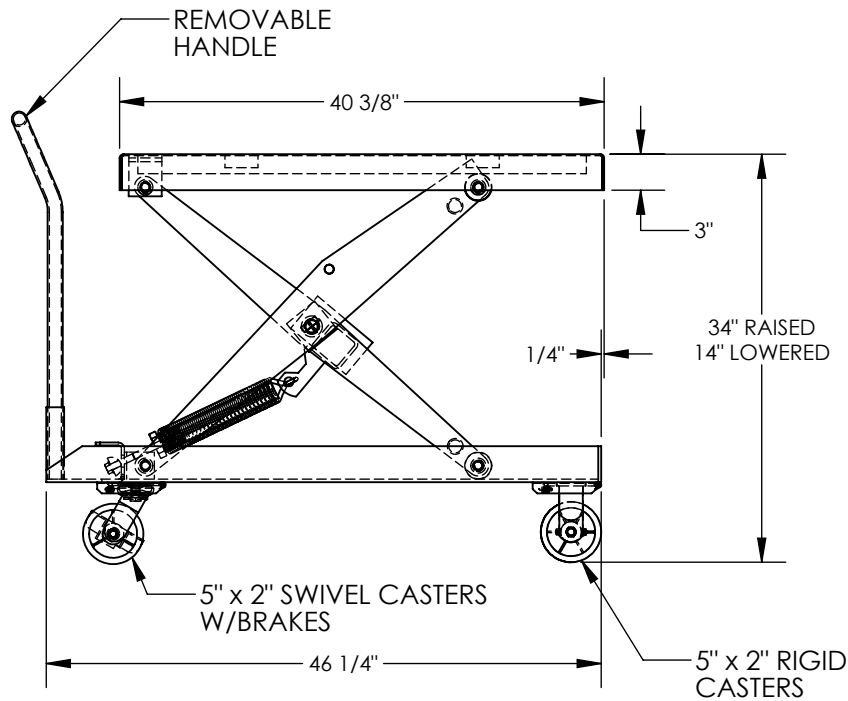

DIMENSION TOLERANCE ± 1/4"

STANDARD FEATURES

MODEL NUMBER IS SCSC-500-2040

OVERALL WIDTH IS 20 3/8"

OVERALL LENGTH IS 46 1/4"

OVERALL HEIGHT IS 37 11/16"

MAX CAPACITY IS 500 LBS.

DECK: 20 3/8" W x 40 3/8" L

FRAME: 20" W x 46 1/4" L

RAISED HEIGHT: 34"

LOWERED HEIGHT: 14"

TRAVEL: 20"

5" x 2" CASTERS (2 SWIVEL W/BRAKE,
2 RIGID)

SPRING RATE: 25 LBS/IN

OF SPRINGS: 2

DURABLE LIQUID PAINT BLUE FINISH

SPECIAL FEATURES

NONE

APPROVAL

I, THE UNDERSIGNED, AGREE THAT THE PRODUCT AS REPRESENTED SATISFIES DESIGN AND DIMENSION REQUIREMENTS. I ALSO ACKNOWLEDGE MY DUTY TO CONFIRM PRODUCT AND INSTALLATION COMPLIANCE WITH ALL APPLICABLE FEDERAL, STATE AND LOCAL REGULATIONS AND STANDARDS.

UNITS REQUIRING APPROVAL DRAWINGS OR MODIFIED ARE NON-RETURNABLE

As drawn As marked

Signed: _____ Date: _____

Printed Name: _____

LEAD TIME WILL START UPON RECEIPT OF SIGNED APPROVAL DRAWING

DISTRIBUTOR'S NAME:		P.O.#
VESTIL MANUFACTURING		X
DRAWN BY: MVG		W.O.#
DATE: 12/27/12		X
REFERENCE: X	SCALE: 1:16	SALES: X
QUOTED LEAD TIME: X	QUOTE #	FILE NAME:
	X	01-007-012