

# WELDED SECURITY CART, BLACK - SCW-XM-3060-BK

APPROX WEIGHT: 435.46 lbs.  
DOES NOT INCLUDE WEIGHT OF POWER OR PACKAGING!!!

\*\*\* ANY ADDITIONS, DELETIONS, OR OMISSIONS MUST BE CORRECTED ON THIS DRAWING AS THIS DRAWING WILL BE CONSIDERED ALL INCLUSIVE \*\*\*

ALL GRAPHICS PROVIDED ARE FOR REFERENCE ONLY. IF CERTAIN DIMENSIONS ARE CRITICAL PLEASE VERIFY THOSE DIMENSIONS WITH YOUR SALESPERSON

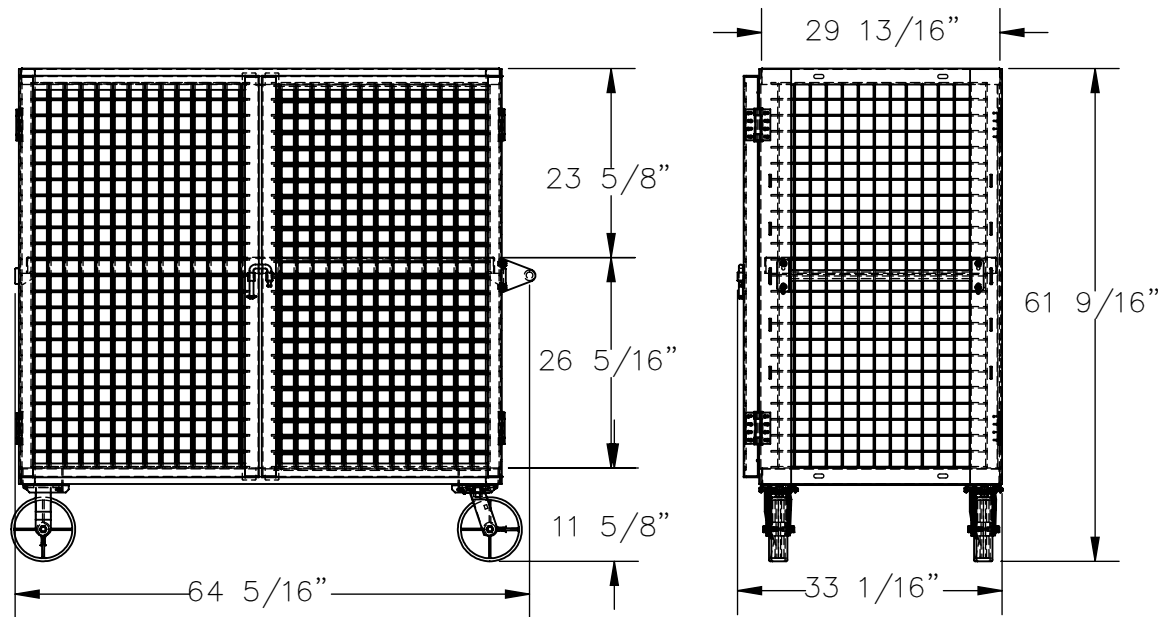
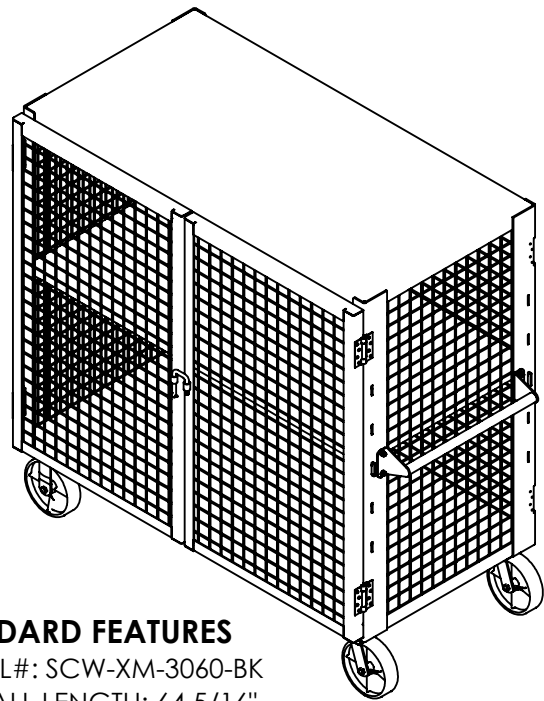

## STANDARD FEATURES

- MODEL#: SCW-XM-3060-BK
- OVERALL LENGTH: 64 5/16"
- OVERALL WIDTH: 33 1/16"
- OVERALL HEIGHT: 61 9/16"
- INCLUDES (2) 8"X2" SWIVEL CASTERS AND (2) 8"X2" RIGID CASTERS
- ADJUSTABLE INSIDE SHELF EVERY 4 1/2"
- ASSEMBLED PUSH HANDLE INCLUDED
- ALL STEEL CONSTRUCTION
- TOUGH BAKED IN POWDER COATED BLACK FINISH
- TOTAL CAPACITY: 2000 LBS. (1000 LBS. PER SHELF)

## SPECIAL FEATURES

NONE

DIMENSION TOLERANCE ± 1/4"

**APPROVAL**

I, THE UNDERSIGNED, AGREE THAT THE PRODUCT AS REPRESENTED SATISFIES DESIGN AND DIMENSION REQUIREMENTS. I ALSO ACKNOWLEDGE MY DUTY TO CONFIRM PRODUCT AND INSTALLATION COMPLIANCE WITH ALL APPLICABLE FEDERAL, STATE AND LOCAL REGULATIONS AND STANDARDS.  
**UNITS REQUIRING APPROVAL DRAWINGS OR MODIFIED ARE NON-RETURNABLE**  
[ ] As drawn [ ] As marked

Signed: \_\_\_\_\_ Date: \_\_\_\_\_

Printed Name: \_\_\_\_\_

LEAD TIME WILL START UPON RECEIPT OF SIGNED APPROVAL DRAWING

DISTRIBUTOR'S NAME:		P.O.#
VESTIL MANUFACTURING		X
DRAWN BY: T. HARKRADER		W.O.#
DATE: 08/11/21		X
REFERENCE: X	SCALE: 1:24	SALES: X
QUOTED LEAD TIME: X	QUOTE #	FILE NAME:
	X	33-007-411-001