

WELDED SECURITY CART, SILVER - SCW-XM-3060-SL

APPROX WEIGHT: 435.46 lbs.
DOES NOT INCLUDE WEIGHT OF POWER OR PACKAGING!!!

*** ANY ADDITIONS, DELETIONS, OR OMISSIONS MUST BE CORRECTED ON THIS DRAWING AS THIS DRAWING WILL BE CONSIDERED ALL INCLUSIVE ***

ALL GRAPHICS PROVIDED ARE FOR REFERENCE ONLY. IF CERTAIN DIMENSIONS ARE CRITICAL PLEASE VERIFY THOSE DIMENSIONS WITH YOUR SALESPERSON

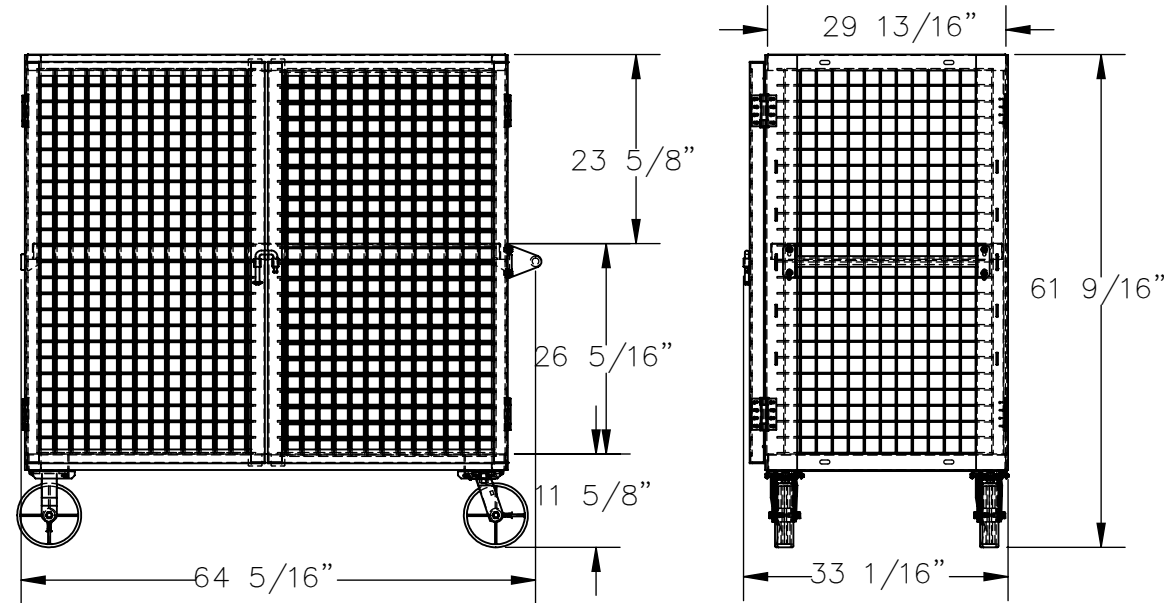
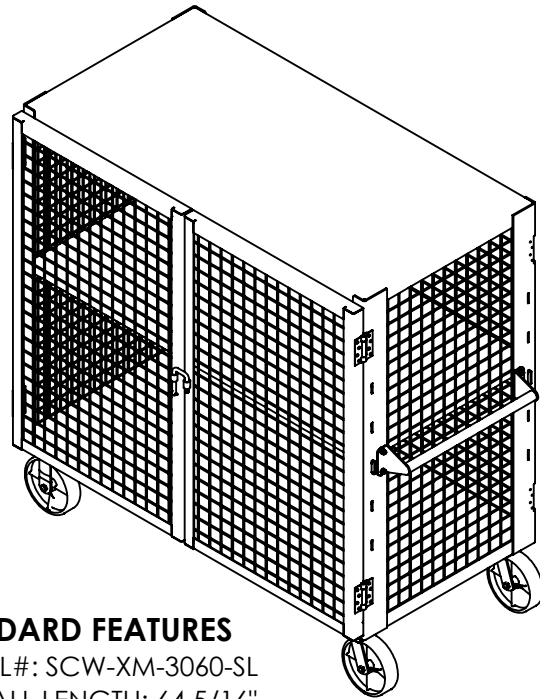

STANDARD FEATURES

- MODEL#: SCW-XM-3060-SL
- OVERALL LENGTH: 64 5/16"
- OVERALL WIDTH: 33 1/16"
- OVERALL HEIGHT: 61 9/16"
- INCLUDES (2) 8"X2" SWIVEL CASTERS AND (2) 8"X2" RIGID CASTERS
- ADJUSTABLE INSIDE SHELF EVERY 4 1/2"
- ASSEMBLED PUSH HANDLE INCLUDED
- ALL STEEL CONSTRUCTION
- TOUGH BAKED IN POWDER COATED SILVER FINISH
- TOTAL CAPACITY: 2000 LBS. (1000 LBS. PER SHELF)

SPECIAL FEATURES

NONE

DIMENSION TOLERANCE $\pm 1/4"$

APPROVAL

I, THE UNDERSIGNED, AGREE THAT THE PRODUCT AS REPRESENTED SATISFIES DESIGN AND DIMENSION REQUIREMENTS. I ALSO ACKNOWLEDGE MY DUTY TO CONFIRM PRODUCT AND INSTALLATION COMPLIANCE WITH ALL APPLICABLE FEDERAL, STATE AND LOCAL REGULATIONS AND STANDARDS.
UNITS REQUIRING APPROVAL DRAWINGS OR MODIFIED ARE NON-RETURNABLE
[] As drawn [] As marked

Signed: _____ Date: _____

Printed Name: _____

LEAD TIME WILL START UPON RECEIPT OF SIGNED APPROVAL DRAWING

DISTRIBUTOR'S NAME:		P.O.#
VESTIL MANUFACTURING		X
DRAWN BY:	DATE:	W.O.#
T. HARKRADER	08/11/21	X
REFERENCE:	SCALE:	FILE NAME:
X	1:24	
QUOTED LEAD TIME:	QUOTE #	33-007-411-005
X	X	