

# FORK HAND TRUCK - SFHT-20-250

APPROX WEIGHT: 52.65 lbs.  
DOES NOT INCLUDE WEIGHT OF POWER OR PACKAGING!!!

\*\*\* ANY ADDITIONS, DELETIONS, OR OMISSIONS MUST BE CORRECTED ON THIS DRAWING AS THIS DRAWING WILL BE CONSIDERED ALL INCLUSIVE \*\*\*  
ALL GRAPHICS PROVIDED ARE FOR REFERENCE ONLY. IF CERTAIN DIMENSIONS ARE CRITICAL PLEASE VERIFY THOSE DIMENSIONS WITH YOUR SALESPERSON

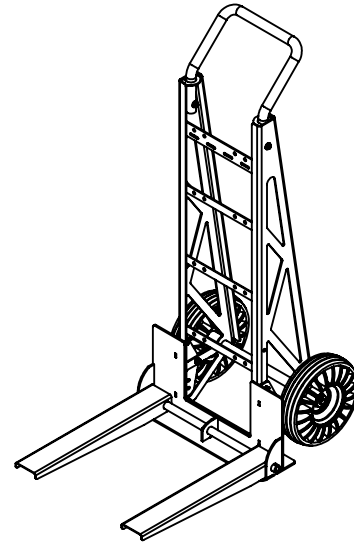
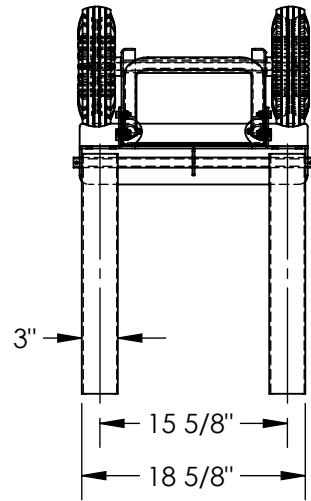

IN USE POSITION

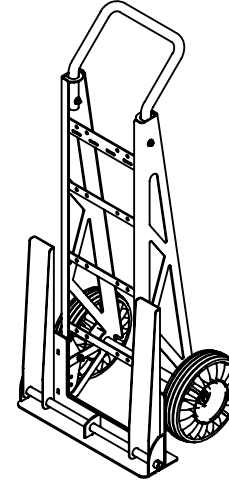

STORAGE POSITION

## STANDARD FEATURES

- MODEL NUMBER IS SFHT-20-250
- OVERALL WIDTH IS 20"
- OVERALL LENGTH IS 32 3/16"
- USABLE LENGTH IS 20 7/16"
- OVERALL HEIGHT IS 49 1/16"
- MAX CAPACITY IS 250 LBS.
- 10" SHOCK ABSORBING WHEELS
- TOUGH BAKED IN POWDER COATED BLUE FINISH
- FOLDABLE FORKS FOR STORAGE
- FORKS ADJUSTABLE FROM 15 5/8" ON CENTER TO 3 3/16" ON CENTER
- FORKS ARE 20" BY 1 3/4"

## SPECIAL FEATURES

NONE

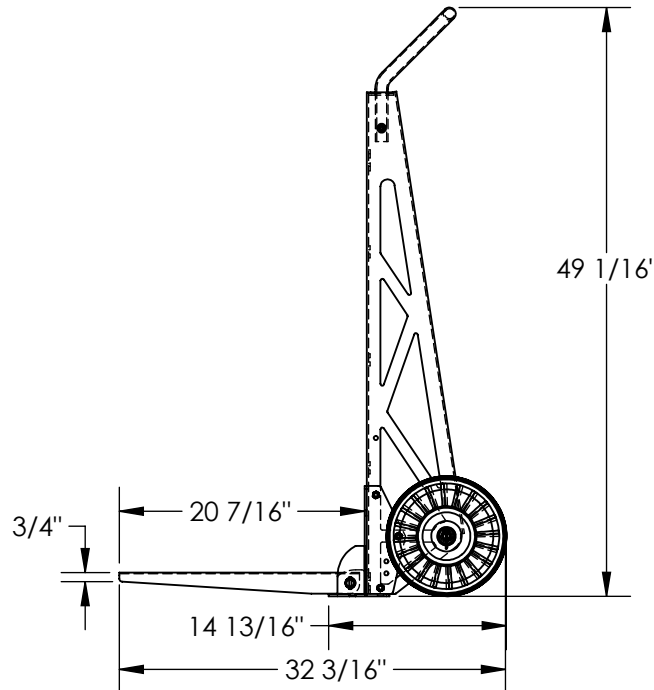
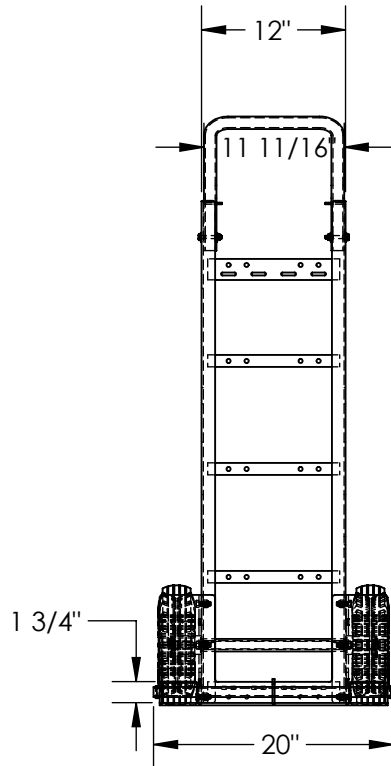

DIMENSION TOLERANCE ± 1/4"

| FOR INTERNAL USE ONLY<br>PROJECT SIGN OFF |  |
|---|--|
| SALES                                     |  |
| ENG.                                      |  |
| FAB.                                      |  |
| POWER                                     |  |

|   |  |  |
|---|--|--|
| <b>APPROVAL</b>   | I, THE UNDERSIGNED, AGREE THAT THE PRODUCT AS REPRESENTED SATISFIES DESIGN AND DIMENSION REQUIREMENTS. I ALSO ACKNOWLEDGE MY DUTY TO CONFIRM PRODUCT AND INSTALLATION COMPLIANCE WITH ALL APPLICABLE FEDERAL, STATE AND LOCAL REGULATIONS AND STANDARDS. |  |
|   | <b>ANY MODIFIED UNITS ARE NON-RETURNABLE</b>   |  |
|   | [ ] As drawn      [ ] As marked  |  |
|   | Signed: _____ Date: _____  |  |
| Printed Name: _____   |  |  |
| <b>LEAD TIME WILL START UPON RECEIPT OF SIGNED APPROVAL DRAWING</b> |  |  |

|                             |             |            |
|-----------------------------|-------------|------------|
| DISTRIBUTOR'S NAME:         |             | P.O.#      |
| <b>VESTIL MANUFACTURING</b> |             | X          |
|                             |             | W.O.#      |
| DRAWN BY: JWW               |             | X          |
| DATE: 1/16/2020             |             | SALES: X   |
| REFERENCE: X                | SCALE: 1:16 | FILE NAME: |
| QUOTED LEAD TIME: X         | QUOTE # X   | 16-007-463 |