

ALUMINUM PALLET - SKID-4824-A

APPROX WEIGHT: 14.90 lbs.
 DOES NOT INCLUDE WEIGHT OF POWER OR PACKAGING!!!

*** ANY ADDITIONS, DELETIONS, OR OMISSIONS MUST BE CORRECTED ON THIS DRAWING AS THIS DRAWING WILL BE CONSIDERED ALL INCLUSIVE ***
 ALL GRAPHICS PROVIDED ARE FOR REFERENCE ONLY. IF CERTAIN DIMENSIONS ARE CRITICAL PLEASE VERIFY THOSE DIMENSIONS WITH YOUR SALESPERSON

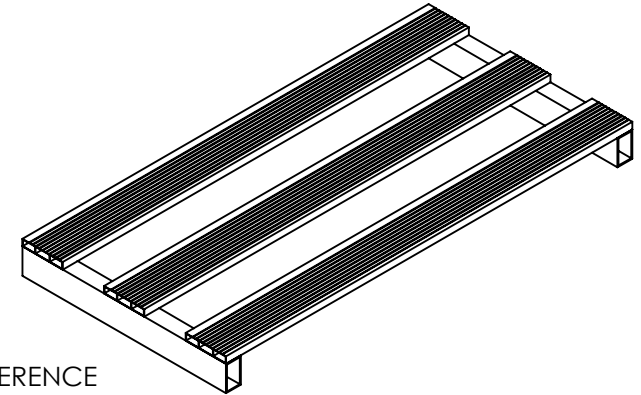
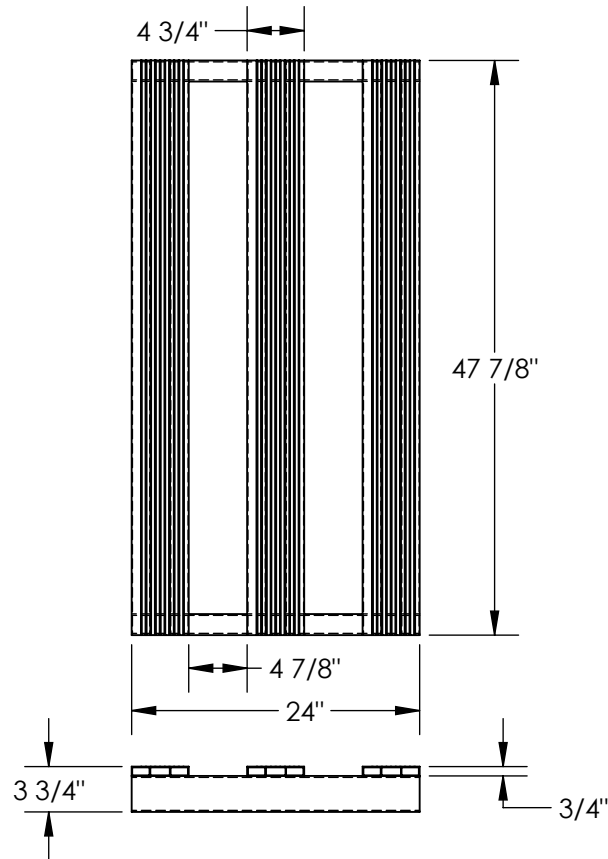

3D VIEW FOR REFERENCE

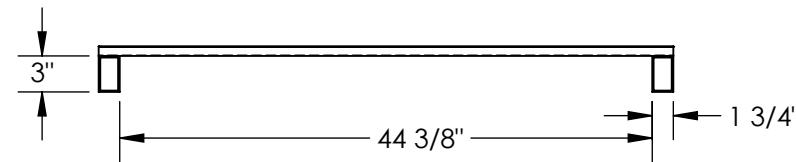

DIMENSION TOLERANCE $\pm 1/4$ "

STANDARD FEATURES

- MODEL NUMBER IS SKID-4824-A
- ALL WELDED ALUMINUM CONSTRUCTION
- OVERALL WIDTH IS 47 7/8"
- OVERALL DEPTH IS 24"
- OVERALL HEIGHT IS 3 3/4"
- THICKNESS OF EXTRUSIONS IS 3/4"
- MAX. CAPACITY IS 4,000 LBS
- EVENLY DISTRIBUTED
- BOTTOM OPENING IS 44 3/8"W x 3"H

SPECIAL FEATURES

NONE

APPROVAL	I, THE UNDERSIGNED, AGREE THAT THE PRODUCT AS REPRESENTED SATISFIES DESIGN AND DIMENSION REQUIREMENTS. I ALSO ACKNOWLEDGE MY DUTY TO CONFIRM PRODUCT AND INSTALLATION COMPLIANCE WITH ALL APPLICABLE FEDERAL, STATE AND LOCAL REGULATIONS AND STANDARDS.	
	UNITS REQUIRING APPROVAL DRAWINGS OR MODIFIED ARE NON-RETURNABLE	
	[] As drawn [] As marked	
	Signed: _____	Date: _____
	Printed Name: _____	
<i>LEAD TIME WILL START UPON RECEIPT OF SIGNED APPROVAL DRAWING</i>		

FOR INTERNAL USE ONLY PROJECT SIGN OFF	
SALES	
ENG.	
FAB.	
POWER	

DISTRIBUTOR'S NAME: VESTIL MANUFACTURING		P.O.# X
DRAWN BY: MTS		W.O.# X
DATE: 10/14/20		SALES: X
REFERENCE: X	SCALE: 1:16	FILE NAME:
QUOTED LEAD TIME: X	QUOTE # X	31-007-350