

"P" HANDLE HAND TRUCK, SPHT-500S-HD-HR

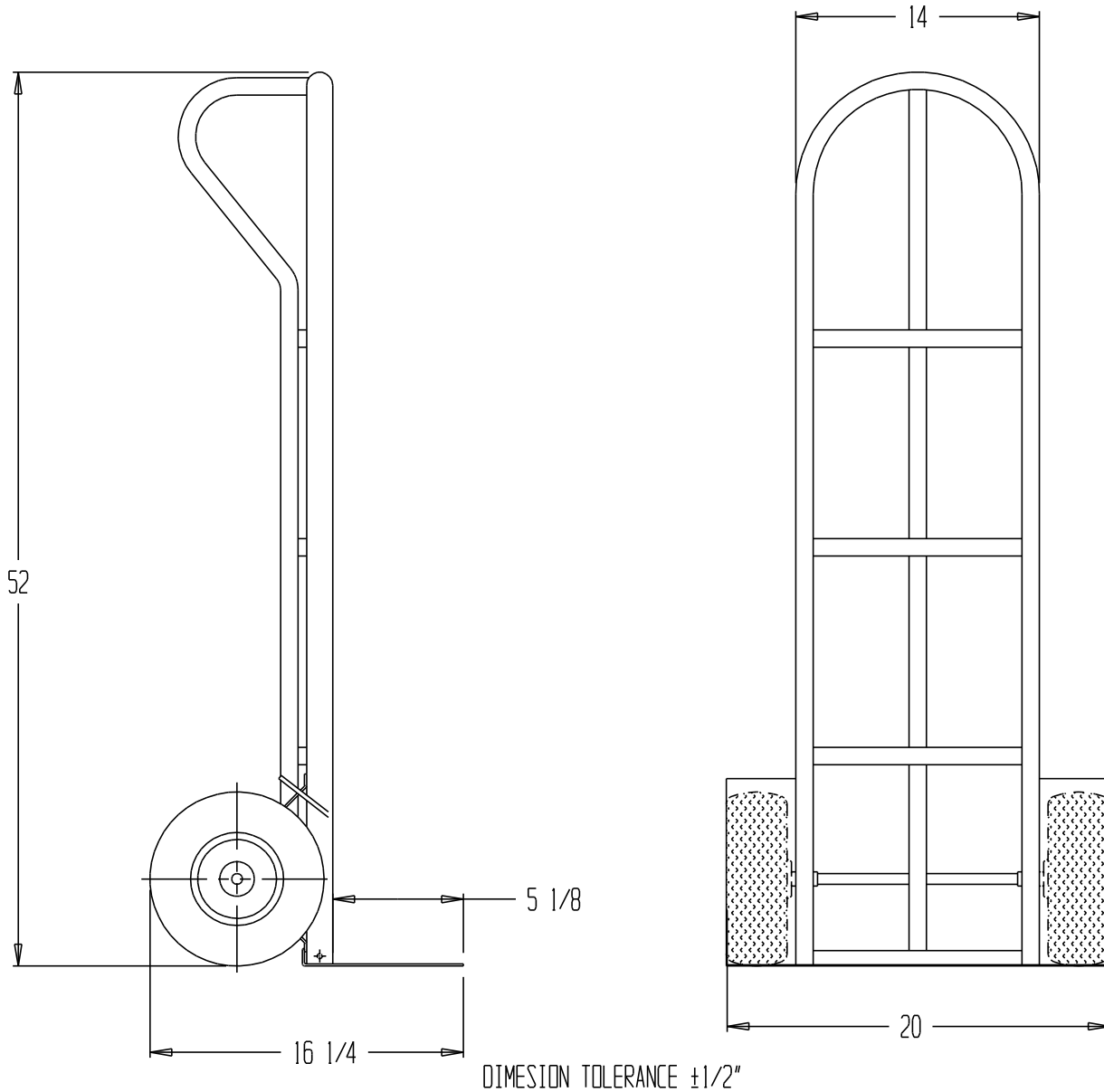

DIMENSION TOLERANCE $\pm 1/2"$

STANDARD FEATURES

MODEL NUMBER: SPHT-500S-HD-HR
 CAPACITY: 600 LBS.
 NOSE PLATE: 20" W x 5 1/8" D
 OVERALL WIDTH: 20"
 OVERALL DEPTH: 16 1/4"
 OVERALL HEIGHT: 52"
 WHEELS: 10" x 2 1/2" HARD RUBBER

Any additions, deletions or omissions must be corrected on this drawing, as this drawing will be considered all inclusive.

SPECIAL FEATURES

NONE

PRODUCTION WILL START UPON RECEIPT OF SIGNED APPROVAL DRAWING

All graphics provided are for reference only. If certain dimensions are critical please verify those dimensions with your salesperson

FOR INTERNAL USE ONLY PROJECT SIGN OFF	
SALES	
ENG	
FAB.	
POWER	

I, THE UNDERSIGNED, AGREE THAT THE PRODUCT AS REPRESENTED SATISFIES DESIGN & DIMENSION REQUIREMENTS. I ALSO ACKNOWLEDGE MY DUTY TO CONFIRM PRODUCT & INSTALLATION COMPLIANCE WITH ALL APPLICABLE FEDERAL, STATE AND LOCAL REGULATIONS & STANDARDS.
ANY MODIFIED UNITS ARE NON-RETURNABLE
 As drawn As marked
 Signed: _____ Date: _____
 Printed Name: _____
 LEAD TIME WILL START UPON RECEIPT OF SIGNED APPROVAL DRAWING

**SPECIAL UNITS ARE NON-RETURNABLE
 *AVAILABLE AT ADDITIONAL COSTS

DISTRIBUTOR'S NAME: VESTIL MANUFACTURING		P.O.#: -
DRAWN BY: SR		DATE: 6-15-06
REFERENCE: -		SCALE: 1:10
QUOTED LEADTIME: -		QUOTE #: -
		SALES: -
		DRWG./FILE NAME: SPHT-500S-HD-HR