

# STEEL HAND TRUCK - SPHT-660-BK

APPROX WEIGHT: 48.99 lbs.  
DOES NOT INCLUDE WEIGHT OF POWER OR PACKAGING!!!

\*\*\*ANY ADDITIONS, DELETIONS, OR OMISSIONS MUST BE CORRECTED ON THIS DRAWING AS THIS DRAWING WILL BE CONSIDERED ALL INCLUSIVE\*\*\*

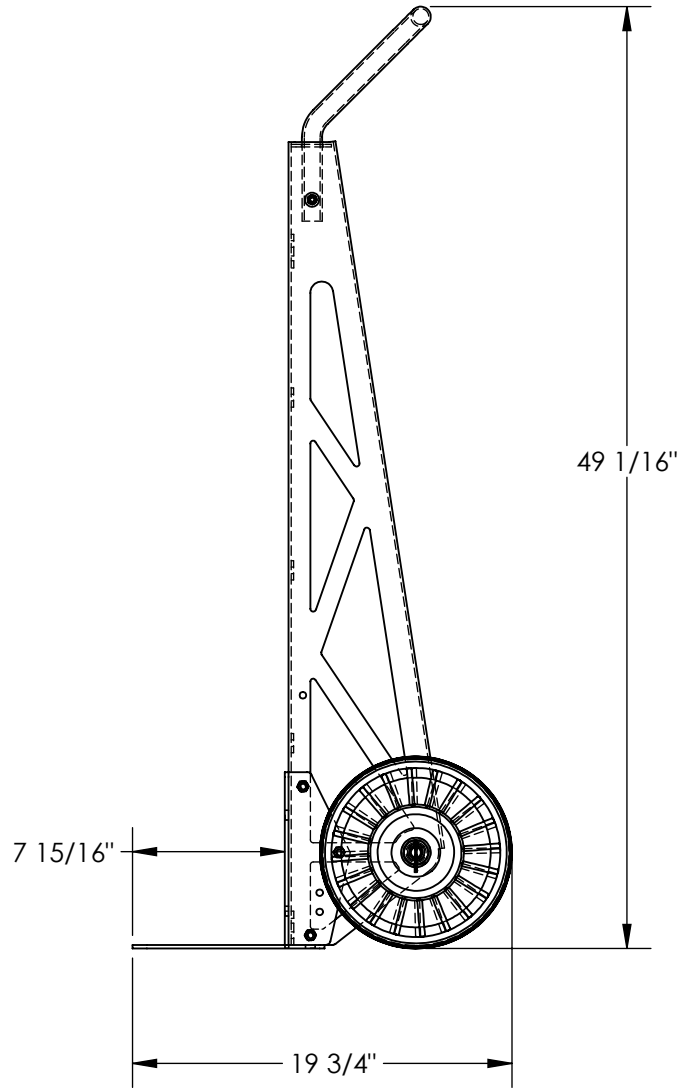
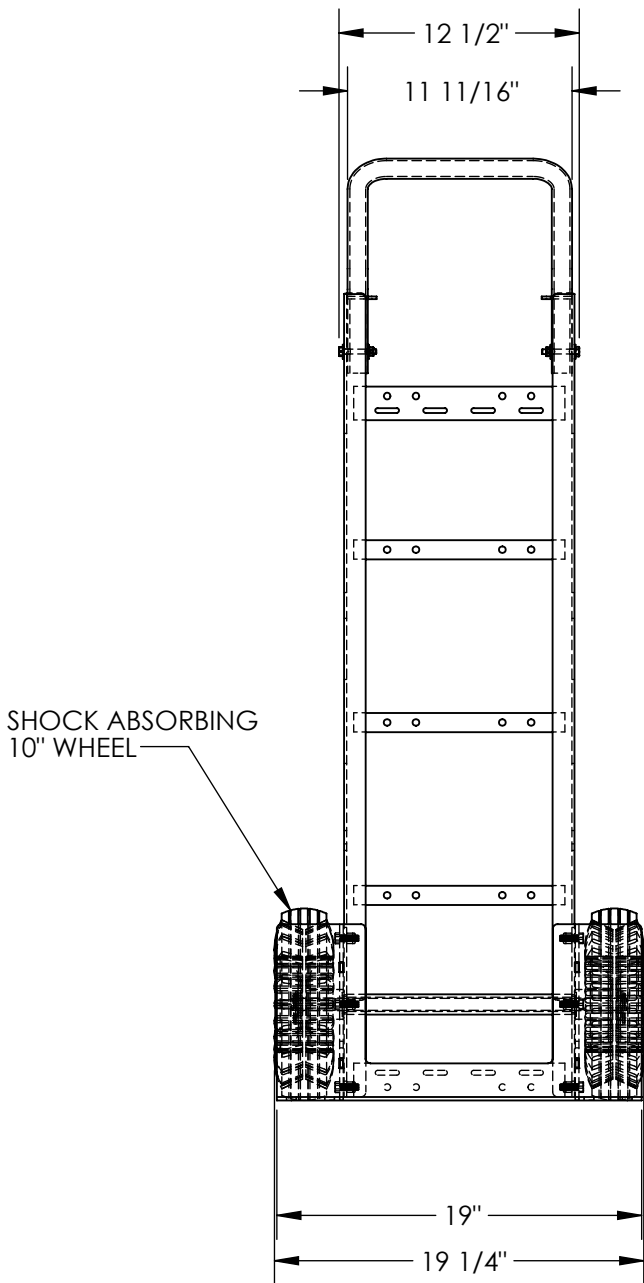

ALL GRAPHICS PROVIDED ARE FOR REFERENCE ONLY. IF CERTAIN DIMENSIONS ARE CRITICAL PLEASE VERIFY THOSE DIMENSIONS WITH YOUR SALESPERSON DIMENSION TOLERANCE ± 1/4"

## STANDARD FEATURES

- MODEL NUMBER IS SPHT-660-BL
- CAPACITY IS 660 LBS
- OVERALL WIDTH IS 19 1/4"
- USABLE WIDTH IS 19"
- OVERALL LENGTH IS 19 3/4"
- USABLE LENGTH IS 7 15/16"
- OVERALL HEIGHT IS 49 1/16"
- TOUGH BAKED IN POWDER COATED BLACK FINISH
- 10" SHOCK ABSORBING WHEELS

## SPECIAL FEATURES

- NONE

<b>A P P R O V A L</b>	I, THE UNDERSIGNED, AGREE THAT THE PRODUCT AS REPRESENTED SATISFIES DESIGN AND DIMENSION REQUIREMENTS. I ALSO ACKNOWLEDGE MY DUTY TO CONFIRM PRODUCT AND INSTALLATION COMPLIANCE WITH ALL APPLICABLE FEDERAL, STATE AND LOCAL REGULATIONS AND STANDARDS.	
	<b>UNITS REQUIRING APPROVAL DRAWINGS OR MODIFIED ARE NON-RETURNABLE</b>	
[ ] As drawn      [ ] As marked		
Signed: _____ Date: _____		
Printed Name: _____		
<i>LEAD TIME WILL START UPON RECEIPT OF SIGNED APPROVAL DRAWING</i>		

DISTRIBUTOR'S NAME:		P.O.#
<b>VESTIL MANUFACTURING</b>		X
DRAWN BY: JGP		W.O.#
DATE: 7/22/2020		X
REFERENCE: X		SALES: X
QUOTED LEAD TIME: X		SCALE: 1:10
QUOTE # X		FILE NAME:
		16-007-501-004