

STEEL SQUARE SAFETY HANDRAIL W/TOEBOARD - SQ-108-TB

APPROX WEIGHT: 70.80 lbs.
DOES NOT INCLUDE WEIGHT OF POWER OR PACKAGING!!!

*** ANY ADDITIONS, DELETIONS, OR OMISSIONS MUST BE CORRECTED ON THIS DRAWING AS THIS DRAWING WILL BE CONSIDERED ALL INCLUSIVE ***
ALL GRAPHICS PROVIDED ARE FOR REFERENCE ONLY. IF CERTAIN DIMENSIONS ARE CRITICAL PLEASE VERIFY THOSE DIMENSIONS WITH YOUR SALESPERSON

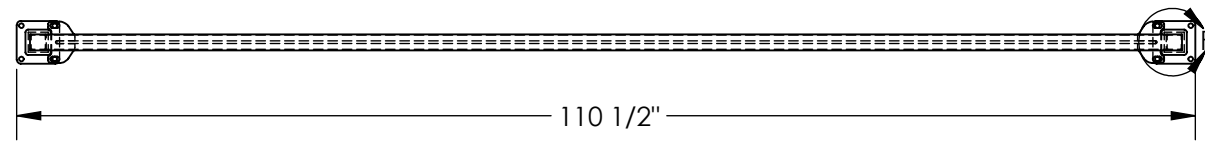
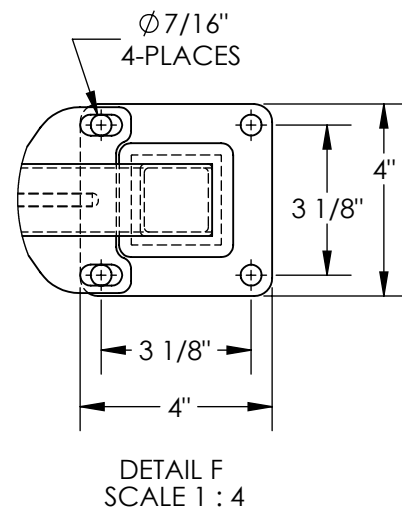
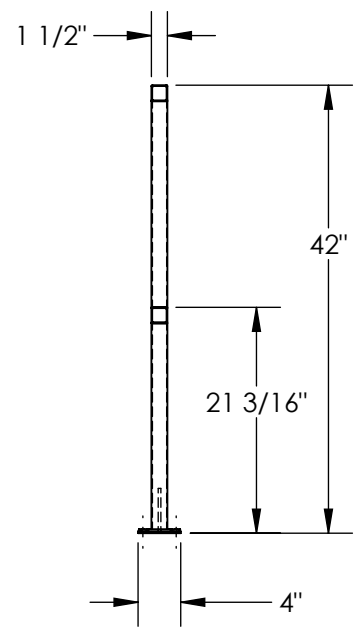
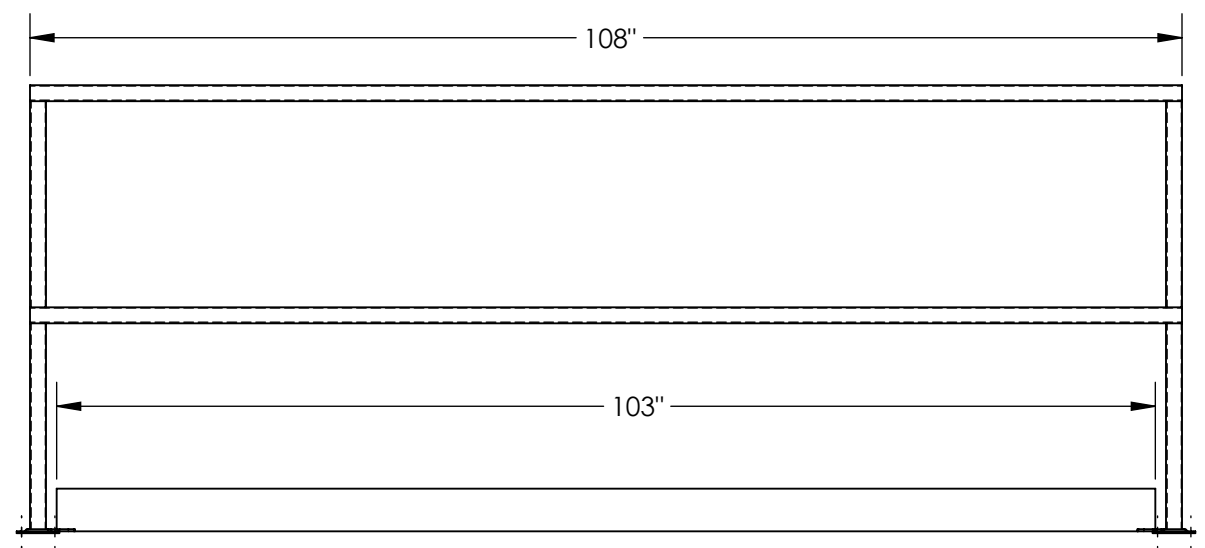

DIMENSION TOLERANCE ± 1/4"

STANDARD FEATURES

- MODEL NUMBER IS SQ-108-TB
- OVERALL WIDTH IS 4"
- USABLE WIDTH IS 1 1/2"
- OVERALL LENGTH IS 110 1/2"
- USABLE LENGTH IS 108"
- OVERALL HEIGHT IS 42"
- MID-RAIL HEIGHT IS 21 3/16"
- INSIDE MOUNTING HOLES ARE 50 1/8" CENTER TO CENTER
- OUTSIDE MOUNTING HOLES ARE 56 3/8" CENTER TO CENTER
- TOEBOARD LENGTH IS 103"
- TOUGH BAKED IN POWDER COAT YELLOW FINISH

SPECIAL FEATURES

NONE

APPROVAL

I, THE UNDERSIGNED, AGREE THAT THE PRODUCT AS REPRESENTED SATISFIES DESIGN AND DIMENSION REQUIREMENTS. I ALSO ACKNOWLEDGE MY DUTY TO CONFIRM PRODUCT AND INSTALLATION COMPLIANCE WITH ALL APPLICABLE FEDERAL, STATE AND LOCAL REGULATIONS AND STANDARDS.
UNITS REQUIRING APPROVAL DRAWINGS OR MODIFIED ARE NON-RETURNABLE
[] As drawn [] As marked

Signed: _____ Date: _____

Printed Name: _____

LEAD TIME WILL START UPON RECEIPT OF SIGNED APPROVAL DRAWING

DISTRIBUTOR'S NAME:		P.O.#
VESTIL MANUFACTURING		X
DRAWN BY: SJA		W.O.#
DATE: 07/13/2015		X
REFERENCE: X	SCALE: 1:18	SALES: X
QUOTED LEAD TIME: X	QUOTE # X	FILE NAME: 23-007-595