

STEEL SQUARE SAFETY HANDRAILS - SQ-120

APPROX WEIGHT: 44.10 lbs.
 DOES NOT INCLUDE WEIGHT OF POWER OR PACKAGING!!!

*** ANY ADDITIONS, DELETIONS, OR OMISSIONS MUST BE CORRECTED ON THIS DRAWING AS THIS DRAWING WILL BE CONSIDERED ALL INCLUSIVE ***
 ALL GRAPHICS PROVIDED ARE FOR REFERENCE ONLY. IF CERTAIN DIMENSIONS ARE CRITICAL PLEASE VERIFY THOSE DIMENSIONS WITH YOUR SALESPERSON

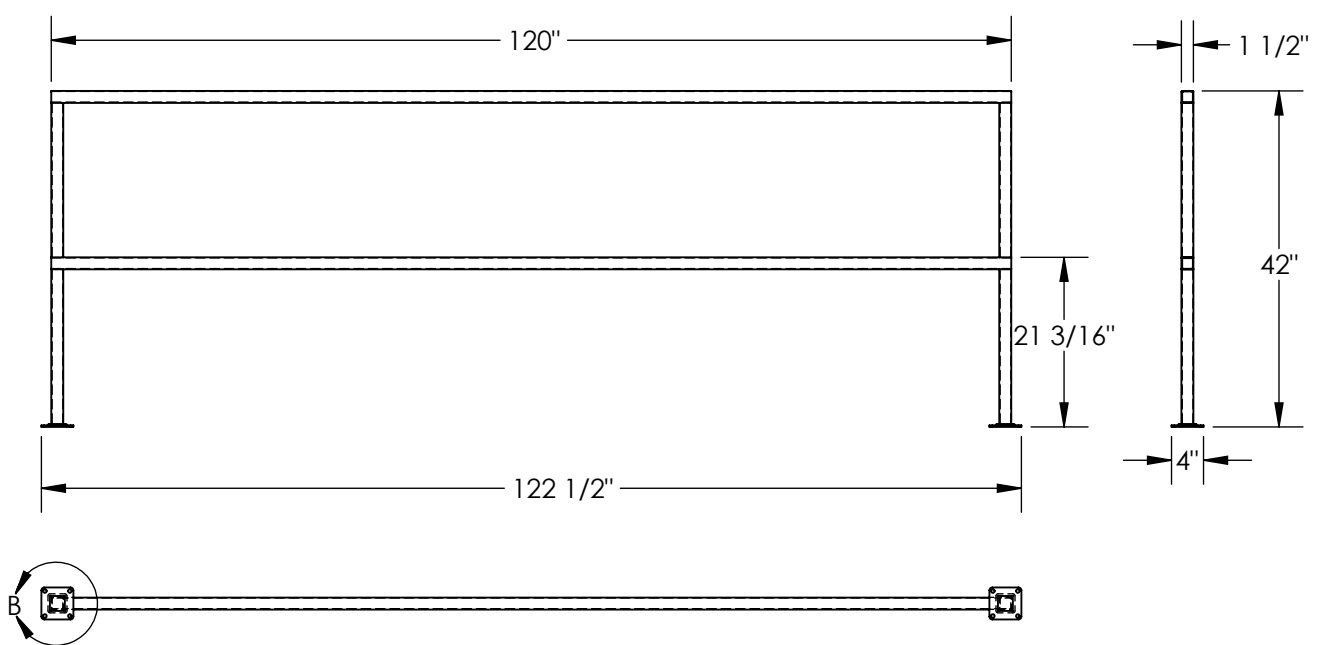
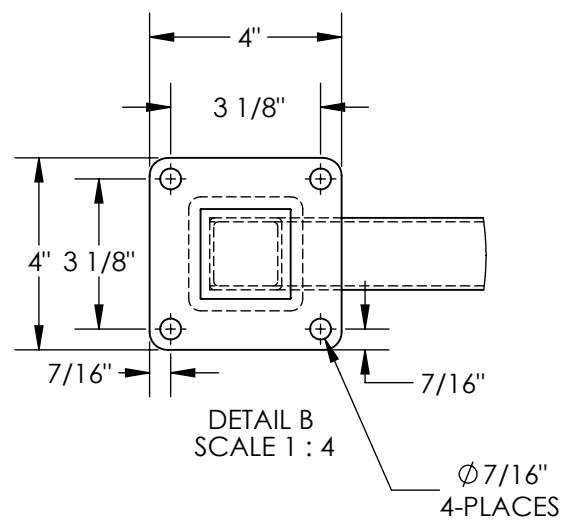

STANDARD FEATURES

- MODEL NUMBER IS SQ-120
- OVERALL WIDTH IS 4"
- OVERALL LENGTH IS 122 1/2"
- USABLE LENGTH IS 120"
- OVERALL HEIGHT IS 42"
- MIDRAIL HEIGHT IS 21 3/16"
- MATERIAL IS 1 1/2" SQUARE TUBING
- TOUGH BAKED IN POWDER COAT
- YELLOW FINISH

SPECIAL FEATURES

NONE

DIMENSION TOLERANCE $\pm 1/4"$

APPROVAL

I, THE UNDERSIGNED, AGREE THAT THE PRODUCT AS REPRESENTED SATISFIES DESIGN AND DIMENSION REQUIREMENTS. I ALSO ACKNOWLEDGE MY DUTY TO CONFIRM PRODUCT AND INSTALLATION COMPLIANCE WITH ALL APPLICABLE FEDERAL, STATE AND LOCAL REGULATIONS AND STANDARDS.

UNITS REQUIRING APPROVAL DRAWINGS OR MODIFIED ARE NON-RETURNABLE

[] As drawn [] As marked

Signed: _____ Date: _____

Printed Name: _____

LEAD TIME WILL START UPON RECEIPT OF SIGNED APPROVAL DRAWING

DISTRIBUTOR'S NAME:		P.O.#
VESTIL MANUFACTURING		X
DRAWN BY: SJA		DATE: 10/23/2014
REFERENCE: X		SALES: X
QUOTED LEAD TIME: X		SCALE: 1:24
QUOTE # X		FILE NAME: 23-007-218