

# STEEL SQUARE SAFETY HANDRAIL W/TOEBOARD - SQ-48-TB

APPROX WEIGHT: 34.72 lbs.  
DOES NOT INCLUDE WEIGHT OF POWER OR PACKAGING!!!

\*\*\* ANY ADDITIONS, DELETIONS, OR OMISSIONS MUST BE CORRECTED ON THIS DRAWING AS THIS DRAWING WILL BE CONSIDERED ALL INCLUSIVE \*\*\*  
ALL GRAPHICS PROVIDED ARE FOR REFERENCE ONLY. IF CERTAIN DIMENSIONS ARE CRITICAL PLEASE VERIFY THOSE DIMENSIONS WITH YOUR SALESPERSON

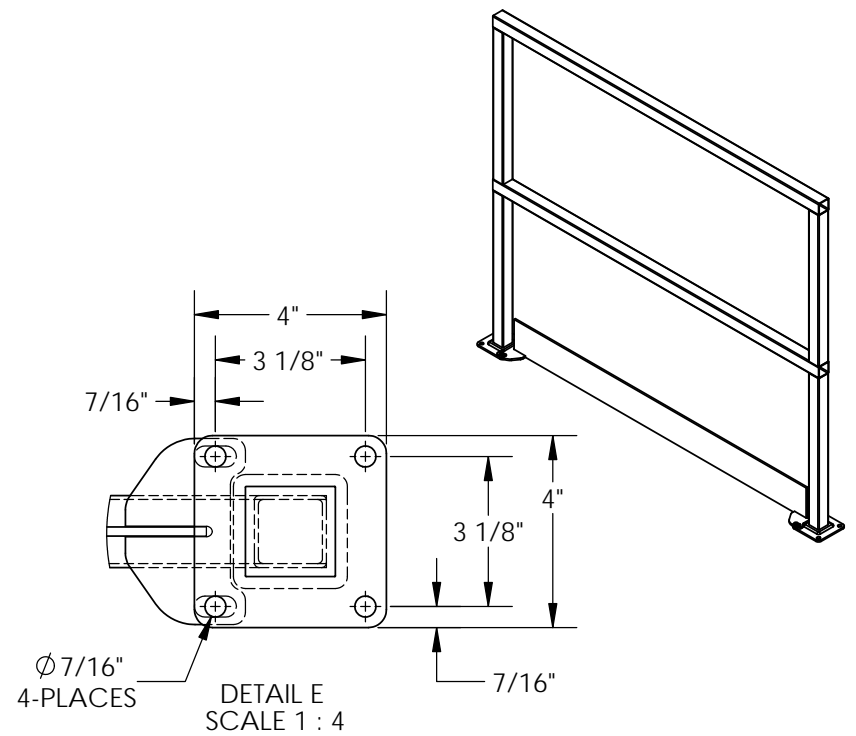
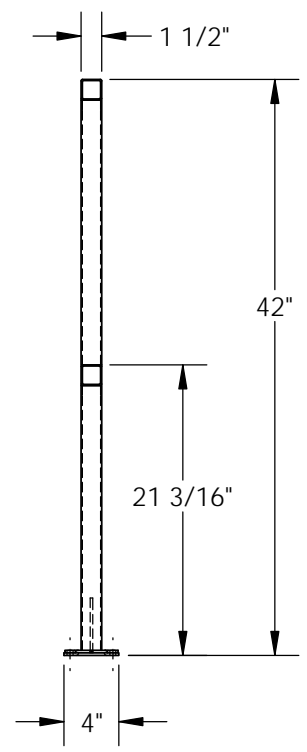
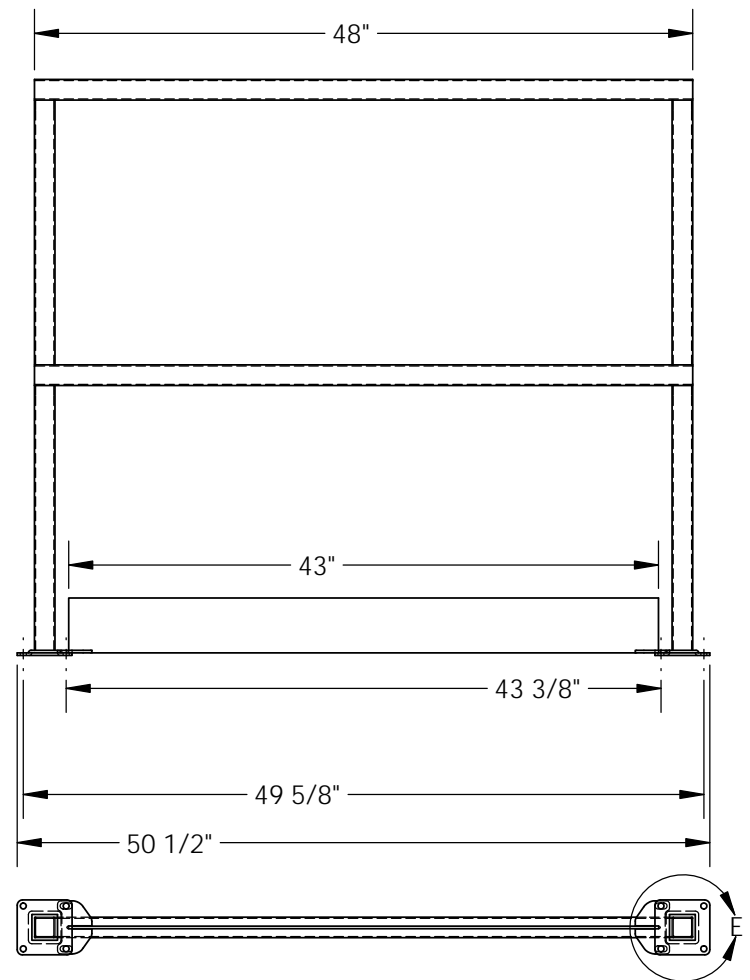

DIMENSION TOLERANCE ± 1/4"

## STANDARD FEATURES

- MODEL NUMBER IS SQ-48-TB
- OVERALL WIDTH IS 4"
- USABLE WIDTH IS 1 1/2"
- OVERALL LENGTH IS 50 1/2"
- USABLE LENGTH IS 48"
- OVERALL HEIGHT IS 42"
- MID-RAIL HEIGHT IS 21 3/16"
- INSIDE MOUNTING HOLES ARE 43 3/8" CENTER TO CENTER
- OUTSIDE MOUNTING HOLES ARE 49 5/8" CENTER TO CENTER
- TOEBOARD LENGTH IS 43"

## SPECIAL FEATURES

NONE

**APPROVAL**

I, THE UNDERSIGNED, AGREE THAT THE PRODUCT AS REPRESENTED SATISFIES DESIGN AND DIMENSION REQUIREMENTS. I ALSO ACKNOWLEDGE MY DUTY TO CONFIRM PRODUCT AND INSTALLATION COMPLIANCE WITH ALL APPLICABLE FEDERAL, STATE AND LOCAL REGULATIONS AND STANDARDS.

**ALL SPECIAL UNITS ARE NON-RETURNABLE**  
[ ] As drawn [ ] As marked

Signed: \_\_\_\_\_ Date: \_\_\_\_\_

**LEAD TIME WILL START UPON RECEIPT OF SIGNED APPROVAL DRAWING**

FOR INTERNAL USE ONLY PROJECT SIGN OFF	
SALES	
ENG.	
FAB.	
POWER	

DISTRIBUTOR'S NAME:		P.O.#
VESTIL MANUFACTURING		X
W.O.#		X
DRAWN BY: SJA	DATE: 07/13/2015	SALES: X
REFERENCE: X	SCALE: 1:14	FILE NAME:
QUOTED LEAD TIME: X	QUOTE # X	23-007-590