

ALUMINUM SQUARE SAFETY HANDRAIL - SQ-A-84

APPROX WEIGHT: 17 lbs.
DOES NOT INCLUDE WEIGHT OF POWER OR PACKAGING!!!

*** ANY ADDITIONS, DELETIONS, OR OMISSIONS MUST BE CORRECTED ON THIS DRAWING AS THIS DRAWING WILL BE CONSIDERED ALL INCLUSIVE ***

ALL GRAPHICS PROVIDED ARE FOR REFERENCE ONLY. IF CERTAIN DIMENSIONS ARE CRITICAL PLEASE VERIFY THOSE DIMENSIONS WITH YOUR SALESPERSON

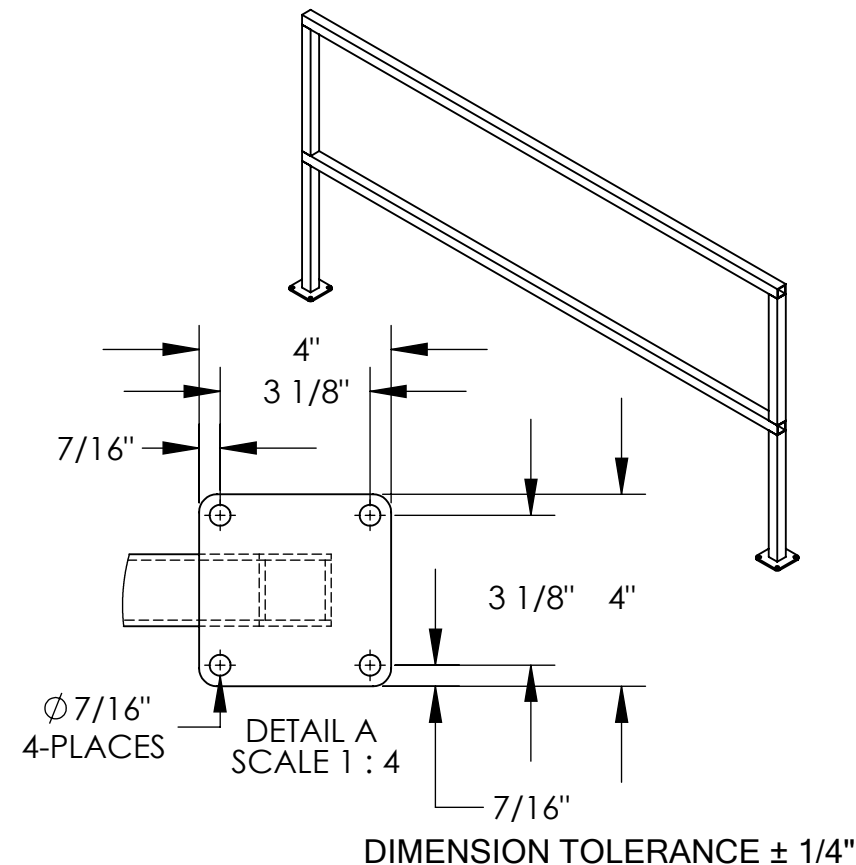
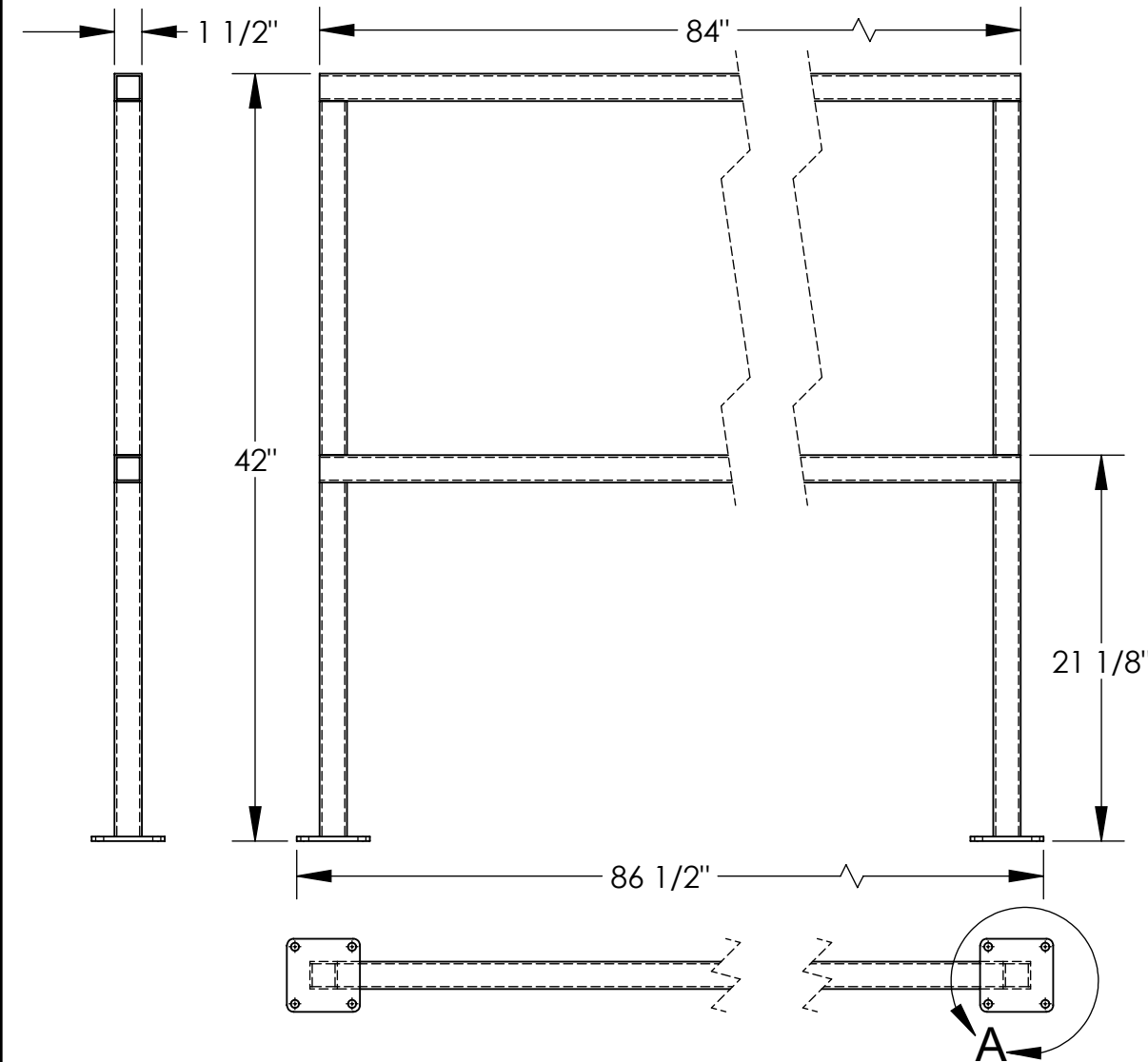

STANDARD FEATURES

- MODEL NUMBER IS SQ-A-84
- OVERALL WIDTH IS 4"
- USABLE WIDTH IS 1 1/2"
- OVERALL LENGTH IS 86 1/2"
- USABLE LENGTH IS 84"
- OVERALL HEIGHT IS 42"
- MIDRAIL HEIGHT IS 21 1/8"
- ALUMINUM CONSTRUCTION

SPECIAL FEATURES

NONE

| FOR INTERNAL USE ONLY PROJECT SIGN OFF | |
|---|--|
| SALES | |
| ENG. | |
| FAB. | |
| POWER | |

| | | |
|---|--|-------------|
| APPROVAL | I, THE UNDERSIGNED, AGREE THAT THE PRODUCT AS REPRESENTED SATISFIES DESIGN AND DIMENSION REQUIREMENTS. I ALSO ACKNOWLEDGE MY DUTY TO CONFIRM PRODUCT AND INSTALLATION COMPLIANCE WITH ALL APPLICABLE FEDERAL, STATE AND LOCAL REGULATIONS AND STANDARDS. | |
| | ANY MODIFIED UNITS ARE NON-RETURNABLE | |
| | [] As drawn [] As marked | |
| | Signed: _____ | Date: _____ |
| | Printed Name: _____ | |
| LEAD TIME WILL START UPON RECEIPT OF SIGNED APPROVAL DRAWING | | |

| | | |
|----------------------|-------------|------------|
| DISTRIBUTOR'S NAME: | | P.O.# |
| VESTIL MANUFACTURING | | X |
| DRAWN BY: TAL | | W.O.# |
| DATE: 6/26/2019 | | X |
| REFERENCE: X | SCALE: 1:10 | SALES: X |
| QUOTED LEAD TIME: X | QUOTE # | FILE NAME: |
| | X | 23-007-713 |