

SINGLE RAIL CHOCK/SINGLE RAIL CHOCK COMBO - SRC/SRC

APPROX WEIGHT: 15.81 lbs.
DOES NOT INCLUDE WEIGHT OF POWER OR PACKAGING!!!

*** ANY ADDITIONS, DELETIONS, OR OMISSIONS MUST BE CORRECTED ON THIS DRAWING AS THIS DRAWING WILL BE CONSIDERED ALL INCLUSIVE ***
ALL GRAPHICS PROVIDED ARE FOR REFERENCE ONLY. IF CERTAIN DIMENSIONS ARE CRITICAL PLEASE VERIFY THOSE DIMENSIONS WITH YOUR SALESPERSON

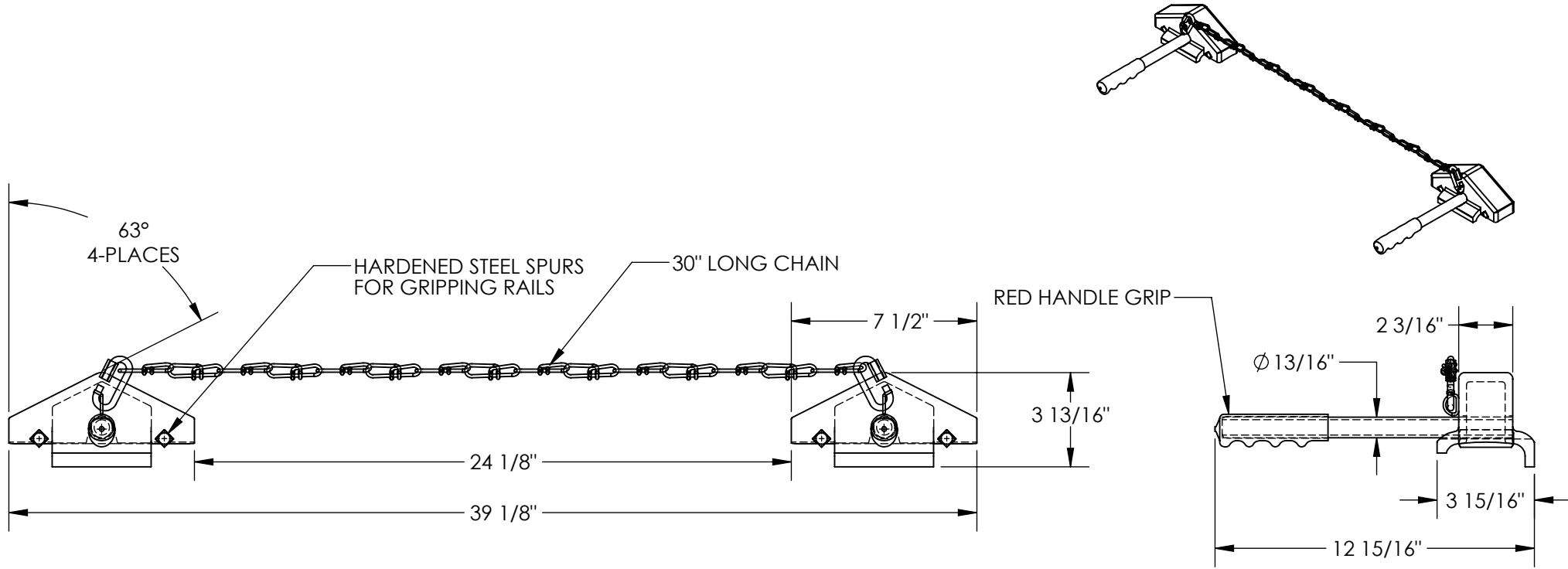

DIMENSION TOLERANCE ± 1/4"

STANDARD FEATURES

- MODEL NUMBER IS SRC/SRC
- OVERALL WIDTH IS 12 15/16"
- CHOCK WIDTH IS 3 15/16"
- OVERALL LENGTH IS 39 1/8"
- CHOCK LENGTH IS 7 1/2"
- OVERALL HEIGHT IS 3 13/16"
- INCLUDES RED HANDLE GRIP
- TOUGH BAKED IN POWDER COATED YELLOW FINISH

SPECIAL FEATURES

NONE

APPROVAL

I, THE UNDERSIGNED, AGREE THAT THE PRODUCT AS REPRESENTED SATISFIES DESIGN AND DIMENSION REQUIREMENTS. I ALSO ACKNOWLEDGE MY DUTY TO CONFIRM PRODUCT AND INSTALLATION COMPLIANCE WITH ALL APPLICABLE FEDERAL, STATE AND LOCAL REGULATIONS AND STANDARDS.
UNITS REQUIRING APPROVAL DRAWINGS OR MODIFIED ARE NON-RETURNABLE
[] As drawn [] As marked

Signed: _____ Date: _____

Printed Name: _____

LEAD TIME WILL START UPON RECEIPT OF SIGNED APPROVAL DRAWING

DISTRIBUTOR'S NAME: VESTIL MANUFACTURING		P.O.# X
DRAWN BY: RPS		W.O.# X
DATE: 9/24/2012	SALES: X	FILE NAME: 29-007-214
REFERENCE: X	SCALE: 1:6	
QUOTED LEAD TIME: X	QUOTE # X	