

# STRAIGHT ARMS WITH NO LIPS - SSAL-12-NL

APPROX WEIGHT: 13.38 lbs.  
 DOES NOT INCLUDE WEIGHT OF POWER OR PACKAGING!!!

\*\*\* ANY ADDITIONS, DELETIONS, OR OMISSIONS MUST BE CORRECTED ON THIS DRAWING AS THIS DRAWING WILL BE CONSIDERED ALL INCLUSIVE \*\*\*

ALL GRAPHICS PROVIDED ARE FOR REFERENCE ONLY. IF CERTAIN DIMENSIONS ARE CRITICAL PLEASE VERIFY THOSE DIMENSIONS WITH YOUR SALESPERSON

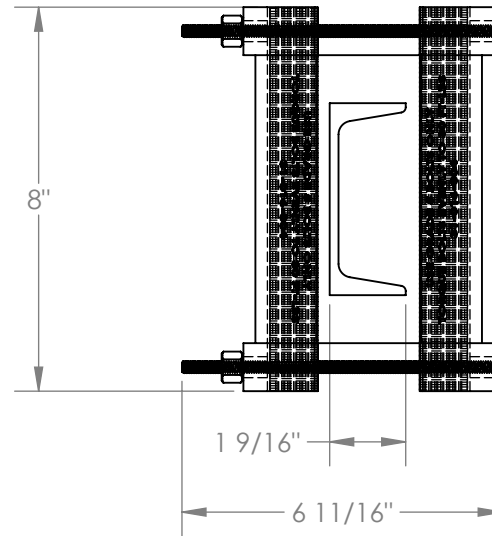
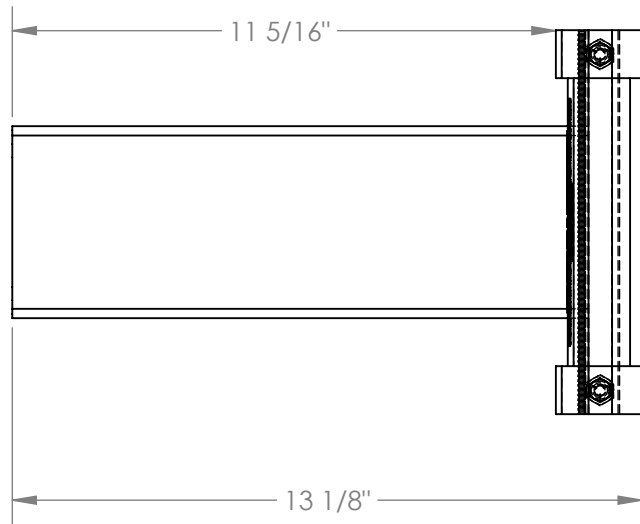

## STANDARD FEATURES

- MODEL NUMBER IS SSAL-12-NL
- OVERALL WIDTH IS 6 11/16"
- USABLE WIDTH IS 1 9/16"
- OVERALL LENGTH IS 13 1/8"
- USABLE LENGTH IS 11 5/16"
- OVERALL HEIGHT IS 8"
- MAX CAPACITY IS 3,000(LBS) PER ARM
- COLOR: BLUE

## SPECIAL FEATURES

NONE

DIMENSION TOLERANCE ± 1/4"

<b>APPROVAL</b>	I, THE UNDERSIGNED, AGREE THAT THE PRODUCT AS REPRESENTED SATISFIES DESIGN AND DIMENSION REQUIREMENTS. I ALSO ACKNOWLEDGE MY DUTY TO CONFIRM PRODUCT AND INSTALLATION COMPLIANCE WITH ALL APPLICABLE FEDERAL, STATE AND LOCAL REGULATIONS AND STANDARDS.	
	<b>ANY MODIFIED UNITS ARE NON-RETURNABLE</b>	
	[ ] As drawn      [ ] As marked	
	Signed: _____ Date: _____	
Printed Name: _____		
<i>LEAD TIME WILL START UPON RECEIPT OF SIGNED APPROVAL DRAWING</i>		

FOR INTERNAL USE ONLY PROJECT SIGN OFF	
SALES	
ENG.	
FAB.	
POWER	

DISTRIBUTOR'S NAME:		P.O.#
VESTIL MANUFACTURING		X
DRAWN BY: STL		W.O.#
DATE: 1/13/2017		X
REFERENCE: X	SCALE: 1:4	SALES: X
QUOTED LEAD TIME: X	QUOTE #	FILE NAME:
	X	31-007-271