

MODULAR STYLE STAIRWAY, STAIR-108

APPROX WEIGHT: 859.13 lbs.
 DOES NOT INCLUDE WEIGHT OF POWER OR PACKAGING!!!

*** ANY ADDITIONS, DELETIONS, OR OMISSIONS MUST BE CORRECTED ON THIS DRAWING AS THIS DRAWING WILL BE CONSIDERED ALL INCLUSIVE ***
 ALL GRAPHICS PROVIDED ARE FOR REFERENCE ONLY. IF CERTAIN DIMENSIONS ARE CRITICAL PLEASE VERIFY THOSE DIMENSIONS WITH YOUR SALESPERSON

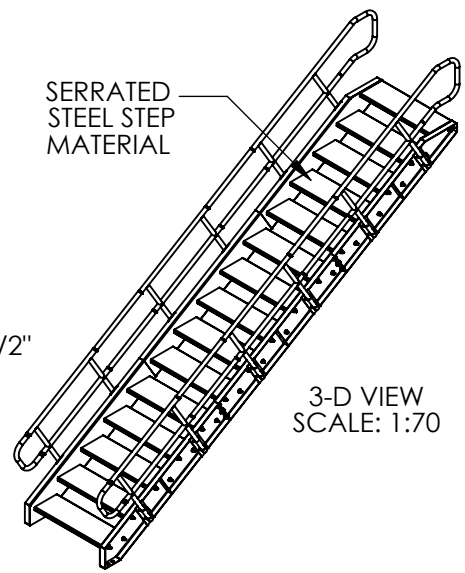
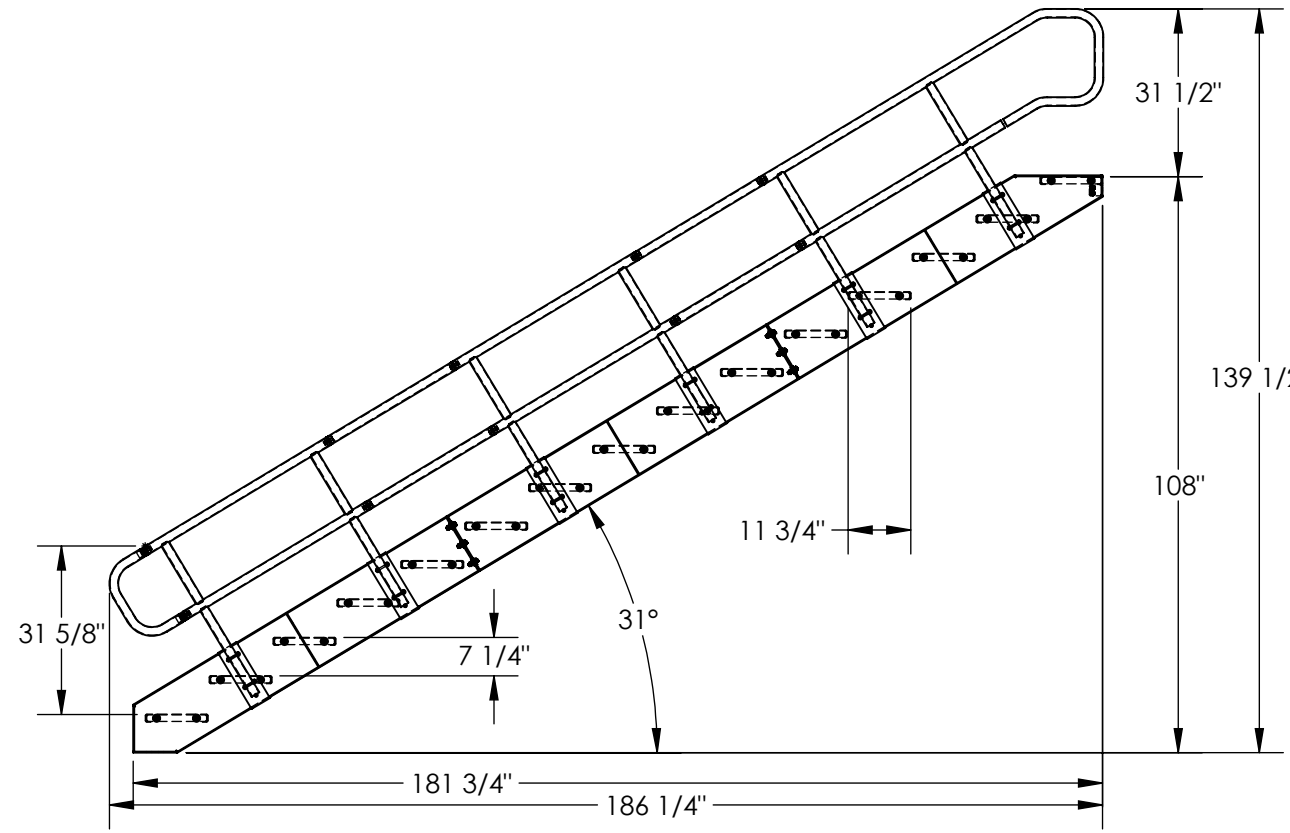
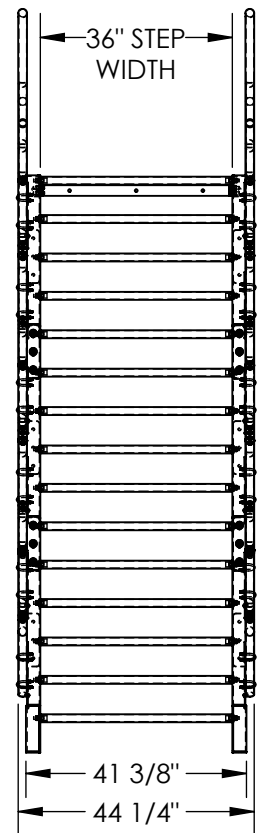

3-D VIEW
 SCALE: 1:70

DIMENSION TOLERANCE ± 1/4"

STANDARD FEATURES

- MODEL NUMBER: STAIR-108
- MAX CAPACITY: 1,000 LBS.
- STEP WIDTH: 36"
- STEP HEIGHT SPACING: 7 1/4"
- TOP STEP HEIGHT: 108"
- RUN DIMENSION: 181 3/4"
- OVERALL DIMENSIONS:
 44 1/4" W x 186 1/4" L x 139 1/2" H
- STEEL TREADPLATE STEP MATERIAL
 (11 3/4" DEEP x 36" WIDE)
- CLIMB ANGLE: 31° (APPROX.)
- STAIR IS TOUGH BAKED IN POWDER COATED BLUE FINISH
- HANDRAIL IS TOUGH BAKED IN POWDER COATED YELLOW FINISH
- MODULAR DESIGN WITH BOLT-ON HANDRAIL
- UNIT SHIPS KNOCKED-DOWN (ASSEMBLY REQUIRED)
- TOP STEP IS FLUSH WITH THE LANDING

SPECIAL FEATURES

NONE

APPROVAL

I, THE UNDERSIGNED, AGREE THAT THE PRODUCT AS REPRESENTED SATISFIES DESIGN AND DIMENSION REQUIREMENTS. I ALSO ACKNOWLEDGE MY DUTY TO CONFIRM PRODUCT AND INSTALLATION COMPLIANCE WITH ALL APPLICABLE FEDERAL, STATE AND LOCAL REGULATIONS AND STANDARDS.
UNITS REQUIRING APPROVAL DRAWINGS OR MODIFIED ARE NON-RETURNABLE
 As drawn As marked

Signed: _____ Date: _____

Printed Name: _____

LEAD TIME WILL START UPON RECEIPT OF SIGNED APPROVAL DRAWING

DISTRIBUTOR'S NAME:		P.O.#
VESTIL MANUFACTURING		X
DRAWN BY: NBE		DATE: 10/11/2021
DATE: 10/11/2021		SALES: X
REFERENCE: X	SCALE: 1:36	FILE NAME:
QUOTED LEAD TIME: X	QUOTE # X	44-007-723