

MODULAR STYLE STAIRWAY, STAIR-84

APPROX WEIGHT: 658.81 lbs.

DOES NOT INCLUDE WEIGHT OF POWER OR PACKAGING!!!

*** ANY ADDITIONS, DELETIONS, OR OMISSIONS MUST BE CORRECTED ON THIS DRAWING AS THIS DRAWING WILL BE CONSIDERED ALL INCLUSIVE ***
 ALL GRAPHICS PROVIDED ARE FOR REFERENCE ONLY. IF CERTAIN DIMENSIONS ARE CRITICAL PLEASE VERIFY THOSE DIMENSIONS WITH YOUR SALESPERSON

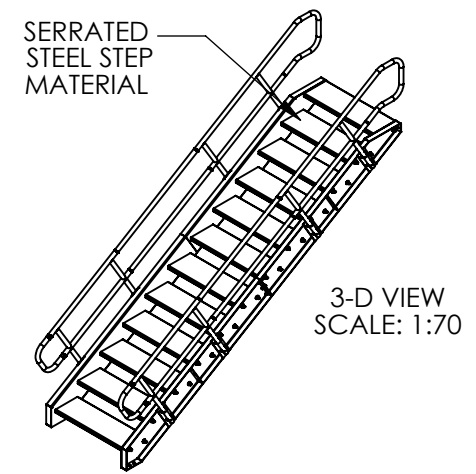
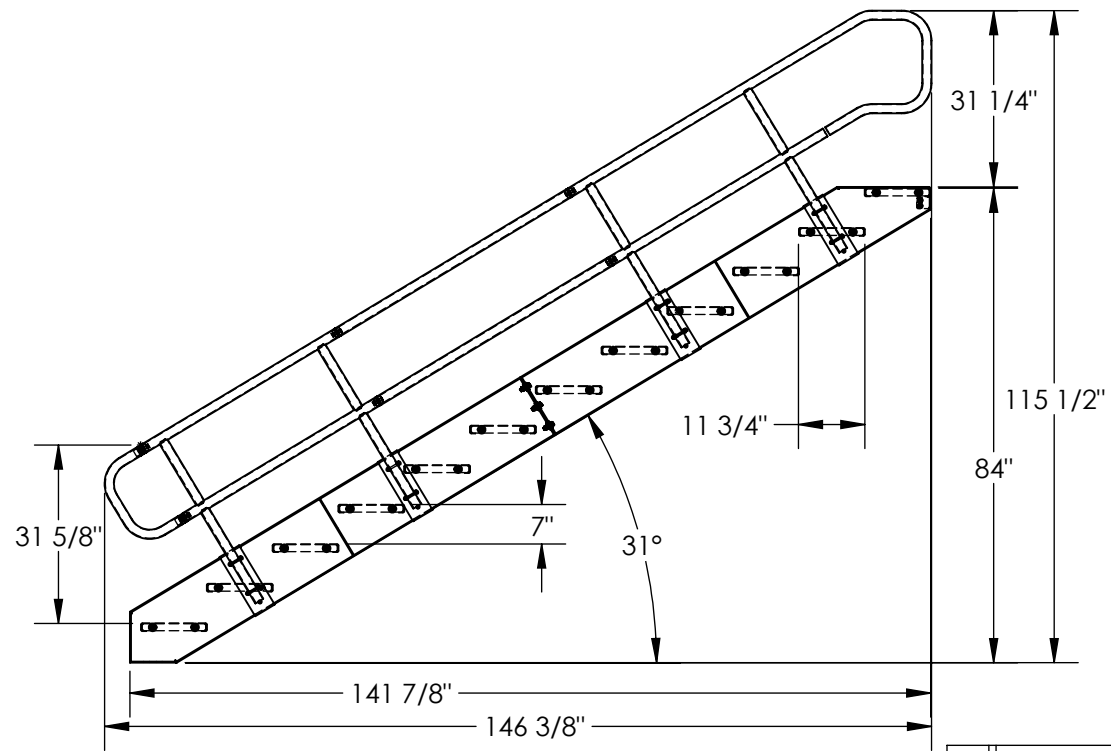
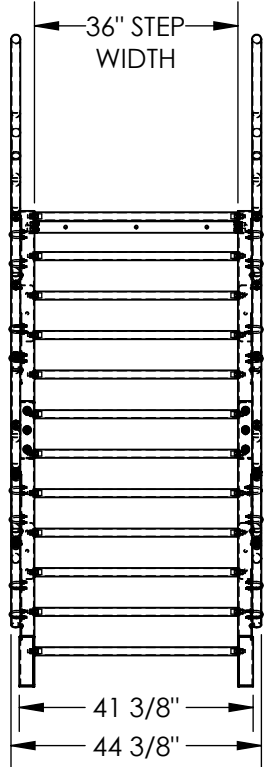

DIMENSION TOLERANCE ± 1/4"

STANDARD FEATURES

- MODEL NUMBER: STAIR-84
- MAX CAPACITY: 1,000 LBS.
- STANDARD STEP WIDTH: 36"
- STEP HEIGHT SPACING: 7"
- TOP STEP HEIGHT: 84"
- RUN DIMENSION: 141 7/8"
- OVERALL DIMENSIONS:
44 3/8" W x 146 3/8" L x 115 1/2" H
- STAIR IS TOUGH BAKED IN POWDER COATED BLUE FINISH
- HANDRAIL IS TOUGH BAKED IN POWDER COATED YELLOW FINISH
- STANDARD MODULAR DESIGN WITH BOLT-ON HANDRAIL
- UNIT SHIPS KNOCKED-DOWN (ASSEMBLY REQUIRED)
- TOP STEP IS FLUSH WITH THE LANDING
- STANDARD SERRATED STEEL STEP MATERIAL
(7" DEEP x 36" WIDE)
- CLIMB ANGLE: 31° (APPROX.)

SPECIAL FEATURES

NONE

APPROVAL

I, THE UNDERSIGNED, AGREE THAT THE PRODUCT AS REPRESENTED SATISFIES DESIGN AND DIMENSION REQUIREMENTS. I ALSO ACKNOWLEDGE MY DUTY TO CONFIRM PRODUCT AND INSTALLATION COMPLIANCE WITH ALL APPLICABLE FEDERAL, STATE AND LOCAL REGULATIONS AND STANDARDS.

UNITS REQUIRING APPROVAL DRAWINGS OR MODIFIED ARE NON-RETURNABLE

[] As drawn [] As marked

Signed: _____ Date: _____

Printed Name: _____

LEAD TIME WILL START UPON RECEIPT OF SIGNED APPROVAL DRAWING

DISTRIBUTOR'S NAME:		P.O.#
VESTIL MANUFACTURING		X
DRAWN BY: NBE	DATE: 10/18/2021	W.O.#
REFERENCE: X	SCALE: 1:34	X
QUOTED LEAD TIME: X	QUOTE #	SALES: X
	X	FILE NAME:
		44-007-721