

SEMI-AUTOMATIC STRETCH WRAP MACHINE - SWA-48-PMO

APPROX WEIGHT: 574.05 lbs.
DOES NOT INCLUDE WEIGHT OF POWER OR PACKAGING!!!

*** ANY ADDITIONS, DELETIONS, OR OMISSIONS MUST BE CORRECTED ON THIS DRAWING AS THIS DRAWING WILL BE CONSIDERED ALL INCLUSIVE ***

ALL GRAPHICS PROVIDED ARE FOR REFERENCE ONLY. IF CERTAIN DIMENSIONS ARE CRITICAL PLEASE VERIFY THOSE DIMENSIONS WITH YOUR SALESPERSON

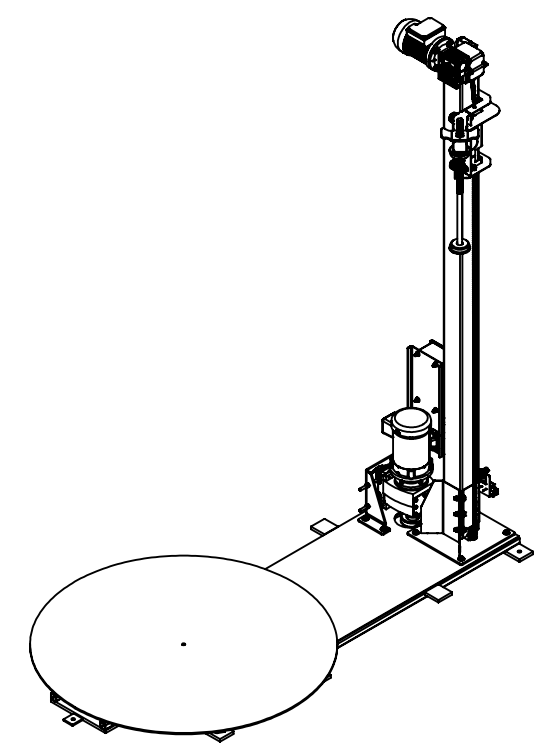
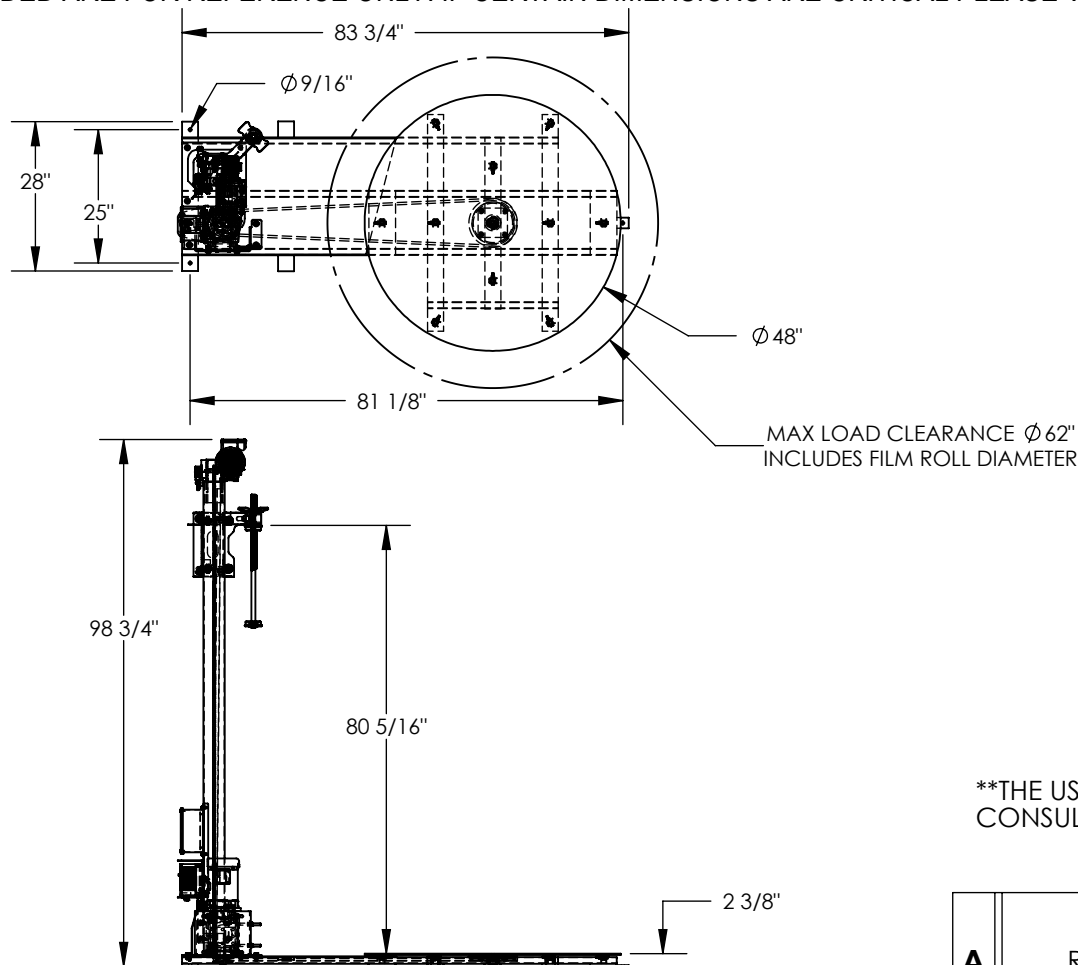

THE USE OF A GFCI WILL REQUIRE THE USE OF A LINE-REACTOR CONSULT YOUR LOCAL ELECTRICAL SUPPLIER FOR DETAILS

DIMENSION TOLERANCE ± 1/4"

STANDARD FEATURES

- MODEL NUMBER IS SWA-48-PMO
- CAPACITY IS 4000 LBS.
- TURN TABLE DIAMETER IS 48"
- OVERALL LENGTH IS 83 3/4"
- OVERALL HEIGHT IS 98 3/4"
- MAX WRAP HEIGHT IS 80 5/16"
- TURN TABLE DECK HEIGHT IS 2 3/8"
- POWER INPUT IS 115 V 1-PHASE
- BELT DRIVEN
- VARIABLE SPEED TURN TABLE (3-12 RPM)
- WITH SOFT START/STOP
- FOOT CONTROL FOR TURN TABLE ROTATION
- 24 V HAND CONTROL FOR MAST MOVEMENT
- DECK IS TOUGH BAKED IN POWDER COAT YELLOW FINISH
- FRAME IS TOUGH BAKED IN POWDER COAT BLUE FINISH

SPECIAL FEATURES

NONE

APPROVAL	I, THE UNDERSIGNED, AGREE THAT THE PRODUCT AS REPRESENTED SATISFIES DESIGN AND DIMENSION REQUIREMENTS. I ALSO ACKNOWLEDGE MY DUTY TO CONFIRM PRODUCT AND INSTALLATION COMPLIANCE WITH ALL APPLICABLE FEDERAL, STATE AND LOCAL REGULATIONS AND STANDARDS.	
	ANY MODIFIED UNITS ARE NON-RETURNABLE	
	[] As drawn	[] As marked
	Signed: _____ Date: _____	
Printed Name: _____		
LEAD TIME WILL START UPON RECEIPT OF SIGNED APPROVAL DRAWING		

<i>FOR INTERNAL USE ONLY</i>	
<i>PROJECT SIGN OFF</i>	
SALES	
ENG.	
FAB.	
POWER	

DISTRIBUTOR'S NAME:		P.O.#
VESTIL MANUFACTURING		X
DRAWN BY: SJA		W.O.#
DATE: 3/6/2017		X
REFERENCE: X	SCALE: 1:36	SALES: X
QUOTED LEAD TIME: X	QUOTE #	FILE NAME:
	X	20-007-189