

SCALE - SWA-48-SCALE

APPROX WEIGHT: 630.93 lbs.
DOES NOT INCLUDE WEIGHT OF POWER OR PACKAGING!!!

ANY ADDITIONS, DELETIONS, OR OMISSIONS MUST BE CORRECTED ON THIS DRAWING AS THIS DRAWING WILL BE CONSIDERED ALL INCLUSIVE

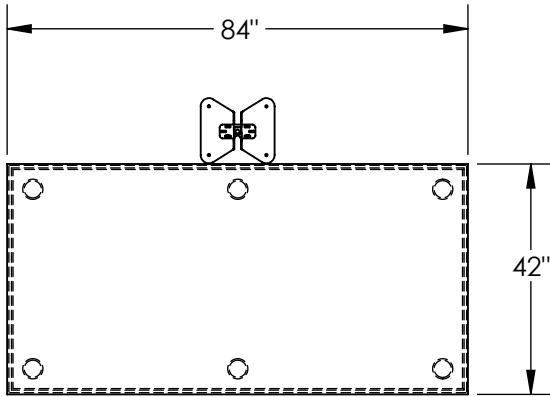

TOP VIEW

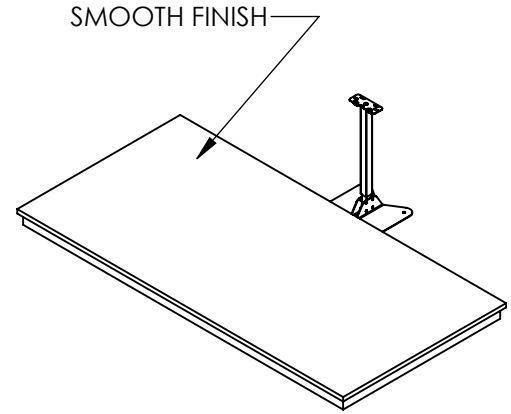

3-D VIEW FOR REFERENCE ONLY

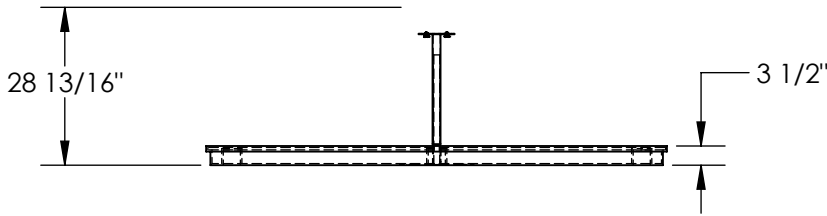

ALL GRAPHICS PROVIDED ARE FOR REFERENCE ONLY. IF CERTAIN DIMENSIONS ARE CRITICAL PLEASE VERIFY THOSE DIMENSIONS WITH YOUR SALESPERSON

STANDARD FEATURES

- MODEL NUMBER IS SWA-48-SCALE
- CAPACITY IS 5,000 LB
- USABLE WIDTH IS 42"
- USABLE LENGTH IS 84"
- OVERALL HEIGHT OF SCALE IS 3 1/2"
- SIX LOAD CELLS & Ø3" HARD RUBBER LEVELING LUGS
- STEEL CONSTRUCTION
- 200% OVER LOAD
- 100% END LOAD
- SMOOTH FINISH
- DURABLE LIQUID PAINT BLUE FINISH

INDICATOR:

- 1" LED DISPLAY
- MILD STEEL NEMA 12 ENCLOSURE W/ MOUNTING BRACKETS
- FULL DUPLEX RS-232 SERIAL PORT
- 110 VAC ADAPTOR W/ 6' CORD
- 8' SCALE CORD
- KG/LB SWITCHABLE
- COUNT
- AUTO HOLD
- CHECK WEIGHING FEATURES
- AUTO DATE & TIME
- AUTO POWER OFF
- POWER SAVE

SPECIAL FEATURES

NONE

FOR INTERNAL USE ONLY PROJECT SIGN OFF	
SALES	
ENG.	
FAB.	
POWER	

DIMENSION TOLERANCE ± 1/4"

A P P R O V A L	I, THE UNDERSIGNED, AGREE THAT THE PRODUCT AS REPRESENTED SATISFIES DESIGN AND DIMENSION REQUIREMENTS. I ALSO ACKNOWLEDGE MY DUTY TO CONFIRM PRODUCT AND INSTALLATION COMPLIANCE WITH ALL APPLICABLE FEDERAL, STATE AND LOCAL REGULATIONS AND STANDARDS.	
	ANY MODIFIED UNITS ARE NON-RETURNABLE	
	[] As drawn [] As marked	
	Signed: _____	Date: _____
Printed Name: _____		
LEAD TIME WILL START UPON RECEIPT OF SIGNED APPROVAL DRAWING		

DISTRIBUTOR'S NAME:		P.O.#
VESTIL MANUFACTURING		X
		W.O.#
DRAWN BY: SJA		X
DATE: 4/4/2017		SALES: X
REFERENCE: X	SCALE: 1:35	FILE NAME:
QUOTED LEAD TIME: X	QUOTE # X	46-007-029