

SCALE - SWA-60-AW-SCL

APPROX WEIGHT: 1140.45 lbs.
DOES NOT INCLUDE WEIGHT OF POWER OR PACKAGING!!!

ANY ADDITIONS, DELETIONS, OR OMISSIONS MUST BE CORRECTED ON THIS DRAWING AS THIS DRAWING WILL BE CONSIDERED ALL INCLUSIVE

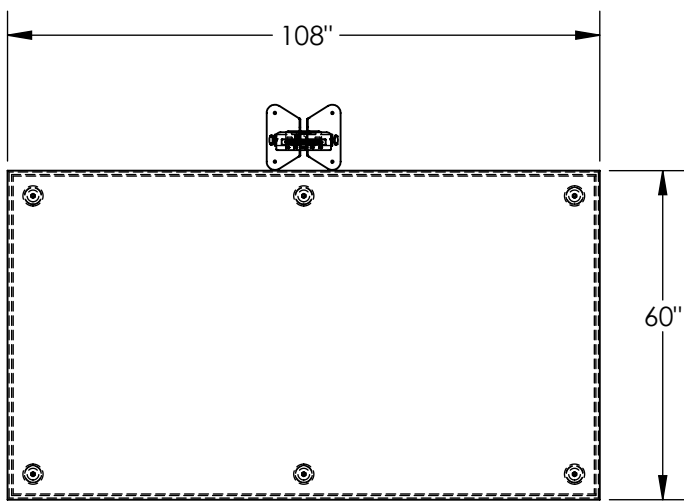

TOP VIEW

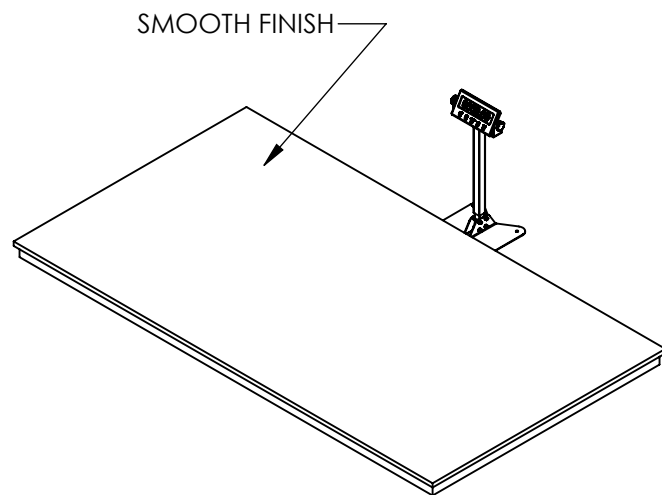

3-D VIEW FOR REFERENCE ONLY

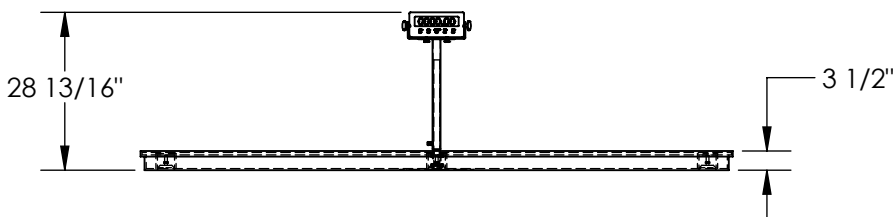

ALL GRAPHICS PROVIDED ARE FOR REFERENCE ONLY. IF CERTAIN DIMENSIONS ARE CRITICAL PLEASE VERIFY THOSE DIMENSIONS WITH YOUR SALESPERSON

STANDARD FEATURES

MODEL NUMBER IS SWA-60-AW-SCL
CAPACITY IS 10,000 LB
USABLE WIDTH IS 60"
USABLE LENGTH IS 108"
OVERALL HEIGHT OF SCALE IS 3 1/2"
SIX LOAD CELLS & Ø3" HARD RUBBER
LEVELING LUGS
STEEL CONSTRUCTION
200% OVER LOAD
100% END LOAD
SMOOTH FINISH
PAINTED: BLUE

INDICATOR:

1" LED DISPLAY
MILD STEEL NEMA 12 ENCLOSURE
W/ MOUNTING BRACKETS
FULL DUPLEX RS-232 SERIAL PORT
110 VAC ADAPTOR W/ 6' CORD
8' SCALE CORD
KG/LB SWITCHABLE
COUNT
AUTO HOLD
CHECK WEIGHING FEATURES
AUTO DATE & TIME
AUTO POWER OFF
POWER SAVE

SPECIAL FEATURES

NONE

FOR INTERNAL USE ONLY PROJECT SIGN OFF	
SALES	
ENG.	
FAB.	
POWER	

DIMENSION TOLERANCE ± 1/4"

APPROVAL

I, THE UNDERSIGNED, AGREE THAT THE PRODUCT AS REPRESENTED SATISFIES DESIGN AND DIMENSION REQUIREMENTS. I ALSO ACKNOWLEDGE MY DUTY TO CONFIRM PRODUCT AND INSTALLATION COMPLIANCE WITH ALL APPLICABLE FEDERAL, STATE AND LOCAL REGULATIONS AND STANDARDS.

ANY MODIFIED UNITS ARE NON-RETURNABLE

As drawn As marked

Signed: _____ Date: _____

Printed Name: _____

LEAD TIME WILL START UPON RECEIPT OF SIGNED APPROVAL DRAWING

DISTRIBUTOR'S NAME:		P.O.#
VESTIL MANUFACTURING		X
DRAWN BY: SJA		W.O.#
DATE: 1/29/2015		X
REFERENCE: X	SCALE: 1:35	SALES: X
QUOTED LEAD TIME: X	QUOTE #	FILE NAME:
	X	46-007-018