

SEMI-AUTOMATIC STRETCH WRAP MACHINE - SWA-60

APPROX WEIGHT: 1438.15 lbs.
 DOES NOT INCLUDE WEIGHT OF POWER OR PACKAGING!!!

*** ANY ADDITIONS, DELETIONS, OR OMISSIONS MUST BE CORRECTED ON THIS DRAWING AS THIS DRAWING WILL BE CONSIDERED ALL INCLUSIVE ***

ALL GRAPHICS PROVIDED ARE FOR REFERENCE ONLY. IF CERTAIN DIMENSIONS ARE CRITICAL PLEASE VERIFY THOSE DIMENSIONS WITH YOUR SALESPERSON

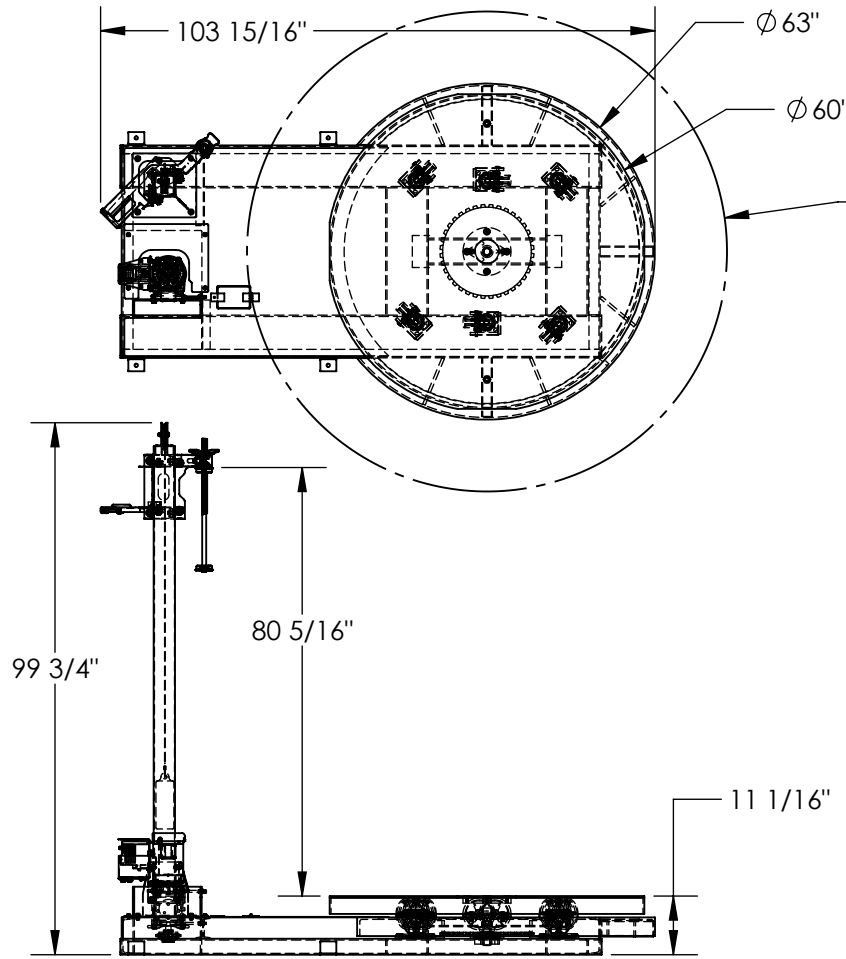

MAX LOAD CLEARANCE IS
 Ø 90" INCLUDES FILM ROLL DIAMETER

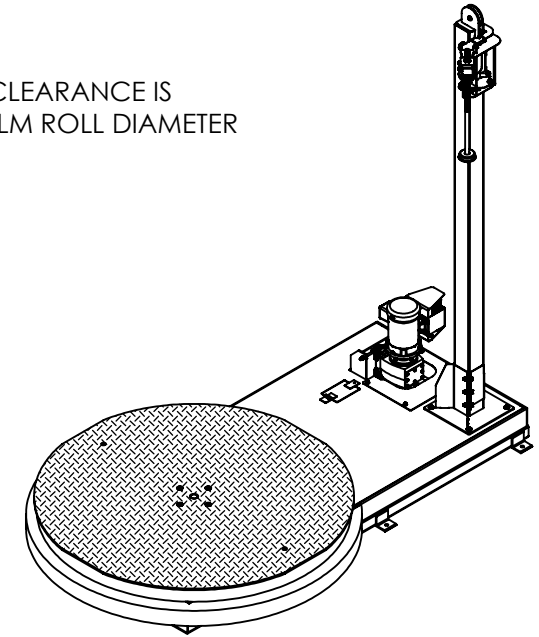

**THE USE OF A GFCI WILL REQUIRE THE USE OF A LINE-REACTOR
 CONSULT YOUR LOCAL ELECTRICAL SUPPLIER FOR DETAILS**

DIMENSION TOLERANCE ± 1/4"

STANDARD FEATURES

- MODEL NUMBER IS SWA-60
- MAX CAPACITY IS 5000 LBS
- TURN TABLE DIAMETER IS Ø60"
- OVERALL LENGTH IS 103 15/16"
- OVERALL HEIGHT IS 99 3/4"
- MAX WRAP HEIGHT IS 80 5/16"
- TURN TABLE DECK HEIGHT IS 11 1/16"
- POWER INPUT IS 115 V 1-PHASE
- CHAIN DRIVEN
- VARIABLE SPEED TURN TABLE
 (3-12 RPM) WITH SOFT START/STOP
- FOOT CONTROL FOR TURNTABLE ROTATION
- DURABLE LIQUID PAINT YELLOW FINISH ON DECK
- DURABLE LIQUID PAINT BLUE FINISH ON FRAME

SPECIAL FEATURES

NONE

APPROVAL

I, THE UNDERSIGNED, AGREE THAT THE PRODUCT AS REPRESENTED SATISFIES DESIGN AND DIMENSION REQUIREMENTS. I ALSO ACKNOWLEDGE MY DUTY TO CONFIRM PRODUCT AND INSTALLATION COMPLIANCE WITH ALL APPLICABLE FEDERAL, STATE AND LOCAL REGULATIONS AND STANDARDS.
UNITS REQUIRING APPROVAL DRAWINGS OR MODIFIED ARE NON-RETURNABLE
 As drawn As marked

Signed: _____ Date: _____

Printed Name: _____

LEAD TIME WILL START UPON RECEIPT OF SIGNED APPROVAL DRAWING

DISTRIBUTOR'S NAME:		P.O.#
VESTIL MANUFACTURING		X
DRAWN BY: SJA		W.O.#
DATE: 1/8/2015		X
REFERENCE: X	SCALE: 1:36	SALES: X
QUOTED LEAD TIME: X	QUOTE #	FILE NAME:
	X	20-007-027