

APPROACH RAMP (SWA-70 W/ SCALE)-SWA-70-R-4860-SCL

APPROX WEIGHT: 312.84 lbs.
DOES NOT INCLUDE WEIGHT OF POWER OR PACKAGING!!!

*** ANY ADDITIONS, DELETIONS, OR OMISSIONS MUST BE CORRECTED ON THIS DRAWING AS THIS DRAWING WILL BE CONSIDERED ALL INCLUSIVE ***

ALL GRAPHICS PROVIDED ARE FOR REFERENCE ONLY. IF CERTAIN DIMENSIONS ARE CRITICAL PLEASE VERIFY THOSE DIMENSIONS WITH YOUR SALESPERSON

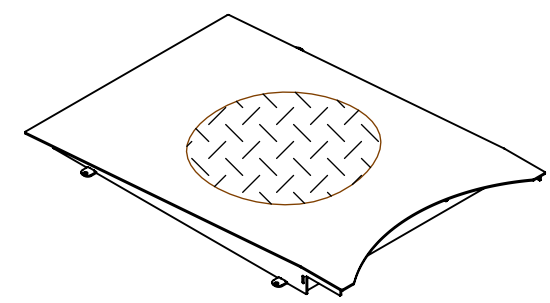
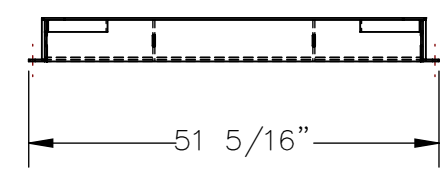
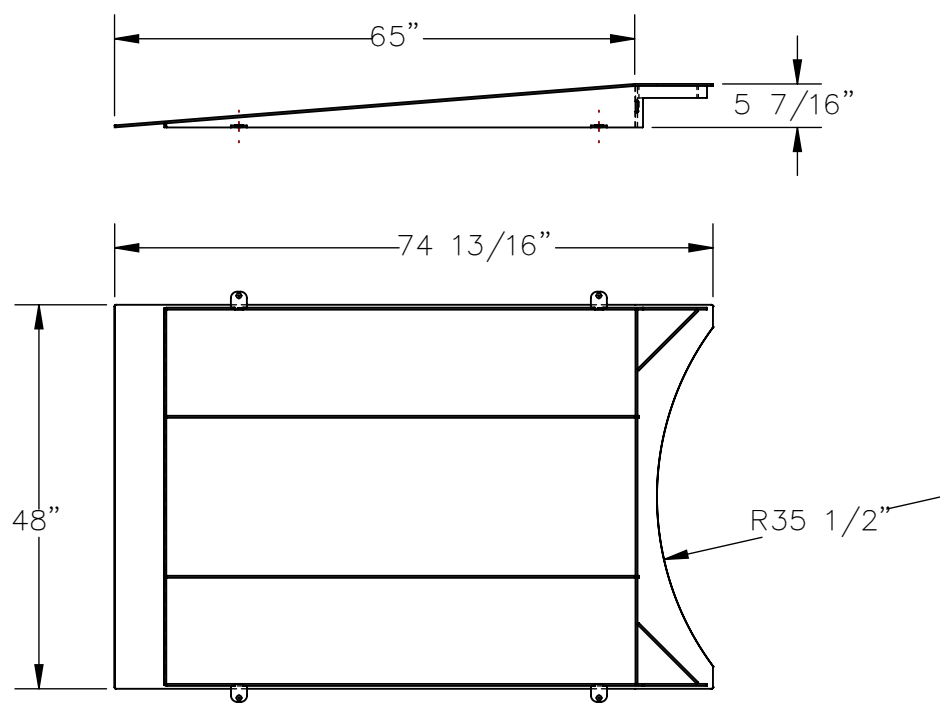

3-D VIEW FOR REFERENCE

STANDARD FEATURES

- MODEL NUMBER IS SWA-70-R-4860-SCL
- OVERALL LENGTH IS 74 13/16"
- OVERALL HEIGHT IS 5 7/16"
- OVERALL WIDTH IS 51 5/16"
- USABLE WIDTH IS 48"
- MAX. CAPACITY IS 4,000 LBS

SPECIAL FEATURES

NONE

DIMENSION TOLERANCE ± 1/4"

**A
P
P
R
O
V
A
L**

I, THE UNDERSIGNED, AGREE THAT THE PRODUCT AS REPRESENTED SATISFIES DESIGN AND DIMENSION REQUIREMENTS. I ALSO ACKNOWLEDGE MY DUTY TO CONFIRM PRODUCT AND INSTALLATION COMPLIANCE WITH ALL APPLICABLE FEDERAL, STATE AND LOCAL REGULATIONS AND STANDARDS.

ANY MODIFIED UNITS ARE NON-RETURNABLE

[] As drawn [] As marked

Signed: _____ Date: _____

Printed Name: _____

LEAD TIME WILL START UPON RECEIPT OF SIGNED APPROVAL DRAWING

FOR INTERNAL USE ONLY PROJECT SIGN OFF	
SALES	
ENG.	
FAB.	
POWER	

DISTRIBUTOR'S NAME:		P.O.#
VESTIL MANUFACTURING		X
DRAWN BY: SJA		DATE: 4/1/2015
REFERENCE: X		SCALE: 1:24
QUOTED LEAD TIME: X		QUOTE #
		X
		FILE NAME:
		20-007-090