

SCALE - SWA-70-SCALE

APPROX WEIGHT: 1394.67 lbs.
DOES NOT INCLUDE WEIGHT OF POWER OR PACKAGING!!!

ANY ADDITIONS, DELETIONS, OR OMISSIONS MUST BE CORRECTED ON THIS DRAWING AS THIS DRAWING WILL BE CONSIDERED ALL INCLUSIVE

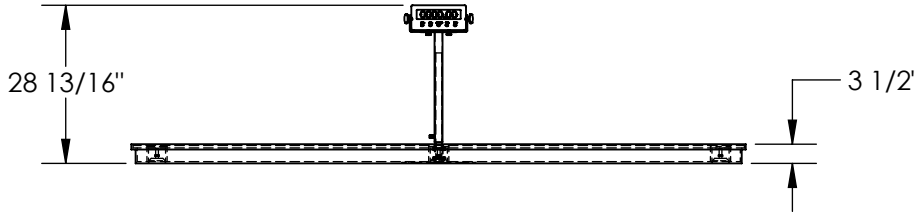
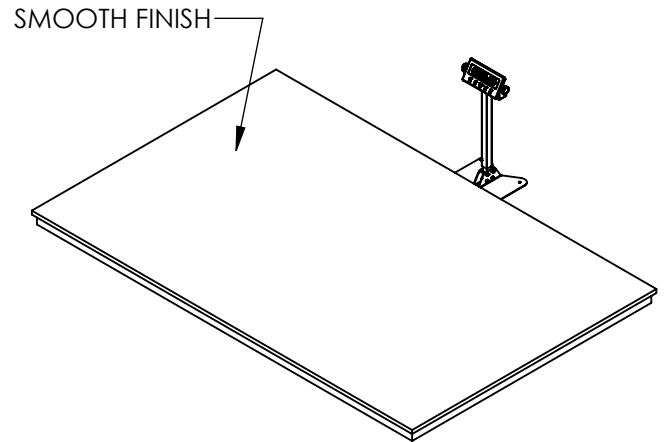
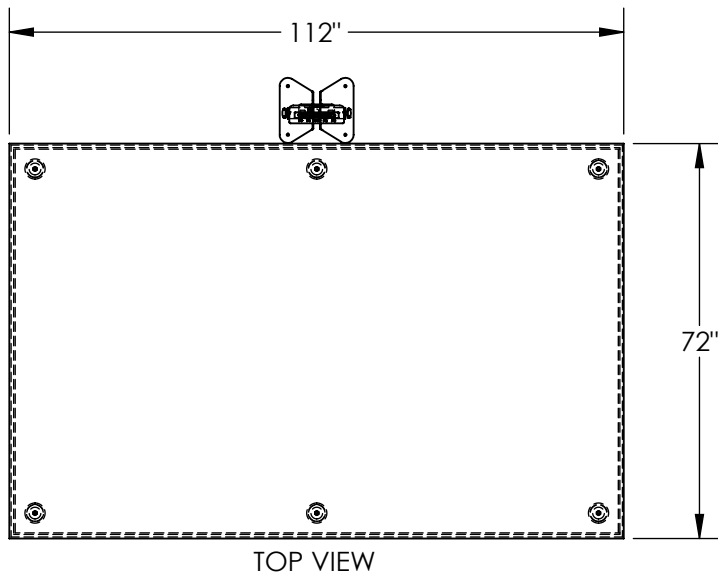

ALL GRAPHICS PROVIDED ARE FOR REFERENCE ONLY. IF CERTAIN DIMENSIONS ARE CRITICAL PLEASE VERIFY THOSE DIMENSIONS WITH YOUR SALESPERSON

STANDARD FEATURES

- MODEL NUMBER IS SWA-70-SCALE
- CAPACITY IS 10,000 LB
- USABLE WIDTH IS 72"
- USABLE LENGTH IS 112"
- OVERALL HEIGHT OF SCALE IS 3 1/2"
- SIX LOAD CELLS & Ø3" HARD RUBBER LEVELING LUGS
- STEEL CONSTRUCTION
- 200% OVER LOAD
- 100% END LOAD
- SMOOTH FINISH
- PAINTED: BLUE

INDICATOR:

- 1" LED DISPLAY
- MILD STEEL NEMA 12 ENCLOSURE W/ MOUNTING BRACKETS
- FULL DUPLEX RS-232 SERIAL PORT
- 110 VAC ADAPTOR W/ 6' CORD
- 8' SCALE CORD
- KG/LB SWITCHABLE COUNT
- AUTO HOLD
- CHECK WEIGHING FEATURES
- AUTO DATE & TIME
- AUTO POWER OFF
- POWER SAVE

SPECIAL FEATURES

NONE

FOR INTERNAL USE ONLY PROJECT SIGN OFF	
SALES	
ENG.	
FAB.	
POWER	

DIMENSION TOLERANCE ± 1/4"

APPROVAL

I, THE UNDERSIGNED, AGREE THAT THE PRODUCT AS REPRESENTED SATISFIES DESIGN AND DIMENSION REQUIREMENTS. I ALSO ACKNOWLEDGE MY DUTY TO CONFIRM PRODUCT AND INSTALLATION COMPLIANCE WITH ALL APPLICABLE FEDERAL, STATE AND LOCAL REGULATIONS AND STANDARDS.

ANY MODIFIED UNITS ARE NON-RETURNABLE

[] As drawn [] As marked

Signed: _____ Date: _____

Printed Name: _____

LEAD TIME WILL START UPON RECEIPT OF SIGNED APPROVAL DRAWING

DISTRIBUTOR'S NAME:		P.O.#
VESTIL MANUFACTURING		X
DRAWN BY: SJA		W.O.#
DATE: 1/30/2015		X
REFERENCE: X	SCALE: 1:35	SALES: X
QUOTED LEAD TIME: X	QUOTE #	FILE NAME:
	X	46-007-028