

FLOOR MOUNTING BRACKET FOR MAST: SWA-MST-FLR

ANY ADDITIONS, DELETIONS, OR OMISSIONS MUST BE CORRECTED ON THIS DRAWING AS THIS DRAWING WILL BE CONSIDERED ALL INCLUSIVE
 APPROX WEIGHT: 19.03 lbs.
 DOES NOT INCLUDE WEIGHT OF POWER OR PACKAGING!!!

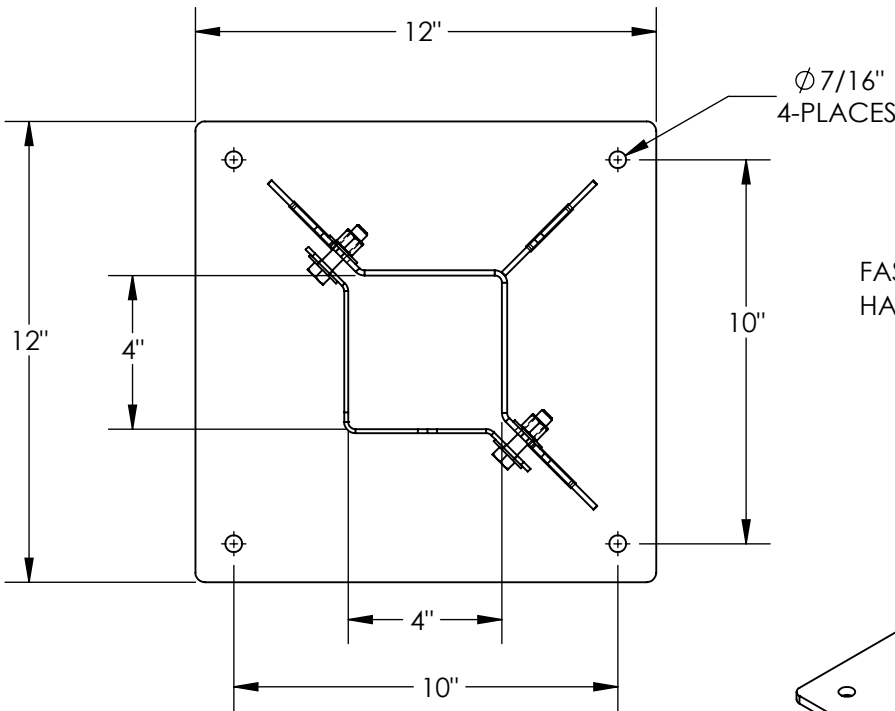

Ø 7/16"
4-PLACES

FASTENING
HARDWARE

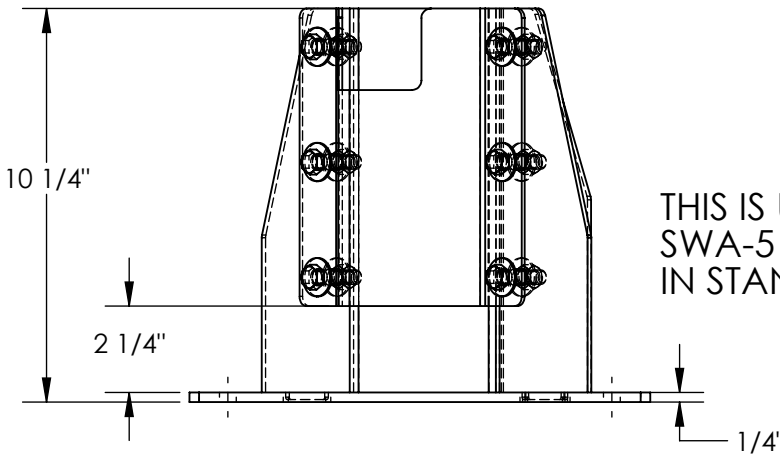
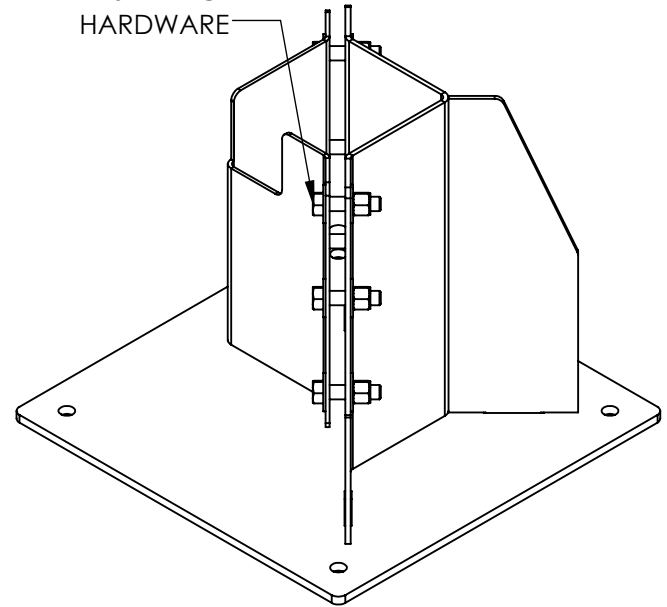

THIS IS USED TO HOLD SWA-50,
SWA-51, OR SWA-70 MANUAL AND PMO MAST
IN STAND-ALONE APPLICATIONS

ALL GRAPHICS PROVIDED ARE FOR REFERENCE ONLY. IF CERTAIN DIMENSIONS ARE CRITICAL PLEASE VERIFY THOSE DIMENSIONS WITH YOUR SALESPERSON

STANDARD FEATURES

- MODEL NUMBER IS SWA-MST-FLR
- OVERALL WIDTH IS: 12"
- OVERALL LENGTH IS: 12"
- OVERALL HEIGHT IS: 10 1/4"
- ACCOMMODATES 4" x 4" UPRIGHT
- (4) Ø 7/16" MOUNTING HOLES
- INCLUDES FASTENING HARDWARE
- **MOUNTING HARDWARE NOT INCLUDED**
- TOUGH BAKED IN POWDER COATED BLUE FINISH**

SPECIAL FEATURES

NONE

APPROVAL

I, THE UNDERSIGNED, AGREE THAT THE PRODUCT AS REPRESENTED SATISFIES DESIGN AND DIMENSION REQUIREMENTS. I ALSO ACKNOWLEDGE MY DUTY TO CONFIRM PRODUCT AND INSTALLATION COMPLIANCE WITH ALL APPLICABLE FEDERAL, STATE AND LOCAL REGULATIONS AND STANDARDS.
UNITS REQUIRING APPROVAL DRAWINGS OR MODIFIED ARE NON-RETURNABLE
 As drawn As marked

Signed: _____ Date: _____

Printed Name: _____

LEAD TIME WILL START UPON RECEIPT OF SIGNED APPROVAL DRAWING

DISTRIBUTOR'S NAME:		P.O.#
VESTIL MANUFACTURING		X
DRAWN BY: SJA		W.O.#
DATE: 06/23/2016		X
REFERENCE: X	SCALE: 1:5	SALES: X
QUOTED LEAD TIME: X	QUOTE #	FILE NAME:
	X	20-007-153