

WHEEL ALIGNMENT CURB - SWAC-144

APPROX WEIGHT: 95.15 lbs.
 DOES NOT INCLUDE WEIGHT OF POWER OR PACKAGING!!!

*** ANY ADDITIONS, DELETIONS, OR OMISSIONS MUST BE CORRECTED ON THIS DRAWING AS THIS DRAWING WILL BE CONSIDERED ALL INCLUSIVE ***

ALL GRAPHICS PROVIDED ARE FOR REFERENCE ONLY. IF CERTAIN DIMENSIONS ARE CRITICAL PLEASE VERIFY THOSE DIMENSIONS WITH YOUR SALESPERSON

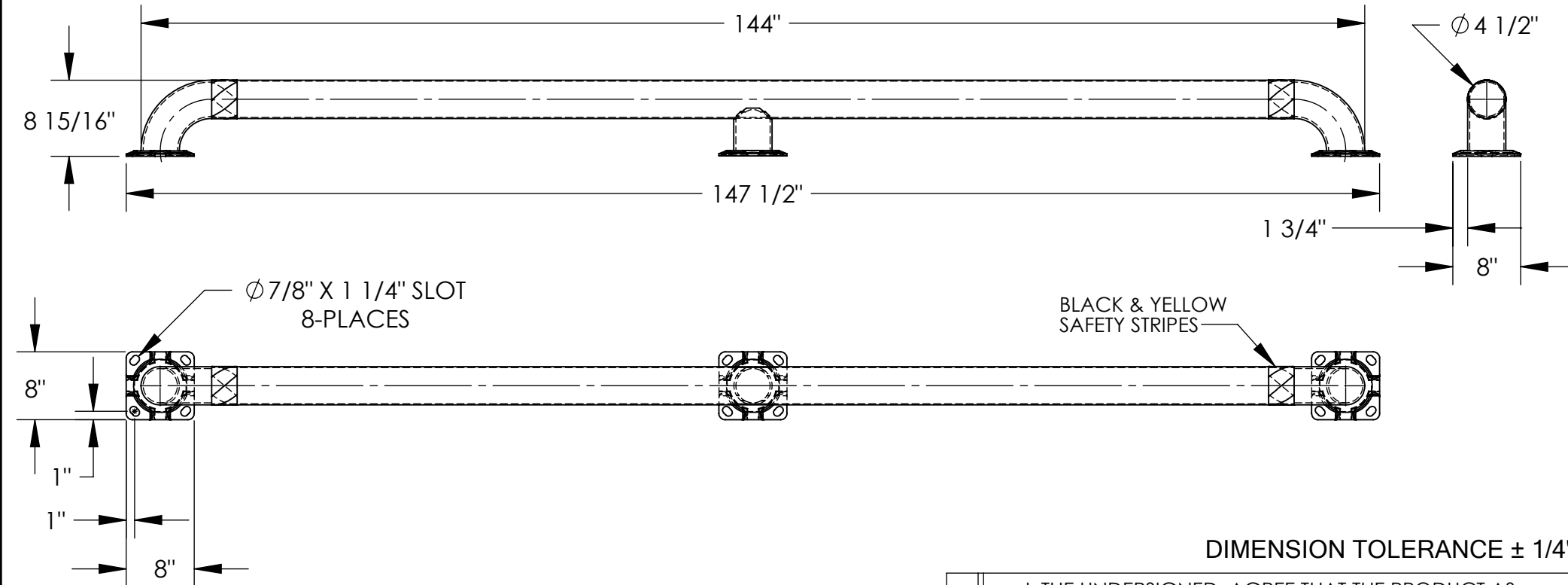

DIMENSION TOLERANCE $\pm 1/4"$

STANDARD FEATURES

MODEL NUMBER IS: SWAC-144
 USABLE LENGTH: 144"
 OVERALL LENGTH: 147 1/2"
 OVERALL HEIGHT: 8 15/16"
 GUARD DIAMETER: $\text{Ø}4\ 1/2"$
 GUARD LENGTH: 144"
 INCLUDES 3 MOUNTING BRACKETS
 TOUGH BAKED IN POWDER COATED
 YELLOW FINISH
 BLACK & YELLOW SAFETY STRIPES
 ALL STEEL CONSTRUCTION
 (ASTM A-36 MIN.) WITH
 WELDING TO MEET AWS
 WARNING: CHECK APPLICABLE STATE
 & LOCAL LAWS FOR YOUR AREA

SPECIAL FEATURES

NONE

APPROVAL

I, THE UNDERSIGNED, AGREE THAT THE PRODUCT AS REPRESENTED SATISFIES DESIGN AND DIMENSION REQUIREMENTS. I ALSO ACKNOWLEDGE MY DUTY TO CONFIRM PRODUCT AND INSTALLATION COMPLIANCE WITH ALL APPLICABLE FEDERAL, STATE AND LOCAL REGULATIONS AND STANDARDS.
UNITS REQUIRING APPROVAL DRAWINGS OR MODIFIED ARE NON-RETURNABLE

As drawn As marked

Signed: _____ Date: _____

Printed Name: _____

LEAD TIME WILL START UPON RECEIPT OF SIGNED APPROVAL DRAWING

DISTRIBUTOR'S NAME:		P.O.#
VESTIL MANUFACTURING		X
DRAWN BY: SR		W.O.#
DATE: 5/21/2008		X
REFERENCE: X	SCALE: 1:17	SALES: X
QUOTED LEAD TIME: X	QUOTE #	FILE NAME:
	X	23-007-026