

SlatTrax[®]

Operation & Technical Manual

Hydraulically Powered System



Table of Contents

Safety Instructions	3
Serial Number Location	3
Attachment Overview	4
Slat Trax Components	4
Operation of Attachment	5
Installing Attachment	5
Trax Length	5
Deploying Trax	6
Retrieving Trax	7
Width Adjustment on Adjustable Spread Attachment	8
Maintenance Items	9
Lubrication	9
Inspection	9
Drive Chain Tension	9
Replacing Adapter Shaft	10
Fixed Spread Attachment	10
Single Spool Attachment and Adjustable Spread Attachment	13
Bearing Replacement	14
Fixed Spread Attachment Parts	16
Adjustable Spread Attachment Parts	18
Manual Handling of Trax	20
Additional Trax	20

Safety Instructions

- ⚠ This safety alert symbol indicates important safety messages in this manual. When you see this symbol, carefully read the messages including all on this page and be alert to the possibility of death or serious injury.
- ⚠ Be sure the attachment is fully secure before operating equipment.
- ⚠ DO NOT operate or service this attachment unless you have read and understood the operator's manual and have been properly trained in the machine's operation.
- ⚠ Refer to the operator's manual for your loader for all safety, operation, maintenance and transport information regarding the loader.
- ⚠ Keep 10 feet of clearance from the attachment when in operation.
- ⚠ No Riders – Riders falling off could be run over and injured or killed. Do not permit others to ride.
- ⚠ Hydraulic oil is a high pressure system. Make sure all lines and fittings are tight and in good condition. These fluids escaping under pressure can have sufficient force to penetrate skin and cause serious injury. NEVER check leaks by using any part of your body to feel for escaping fluids.
- ⚠ Be aware of all pinch points on the machine and keep clear of those areas.
- ⚠ Always replace worn or broken parts immediately after they are discovered. Do not use the attachment or system if any parts are not functioning properly.
- ⚠ Always keep safety and informational decals clean and visible.



Figure 1

Serial Number Location

The serial number is located on the upper rear frame tube next to the attachment mounting plate. (Figure 1)

You may be asked for the attachment serial number when requesting information or when ordering parts for your SlatTrax system.

Attachment Overview

SlatTrax Components

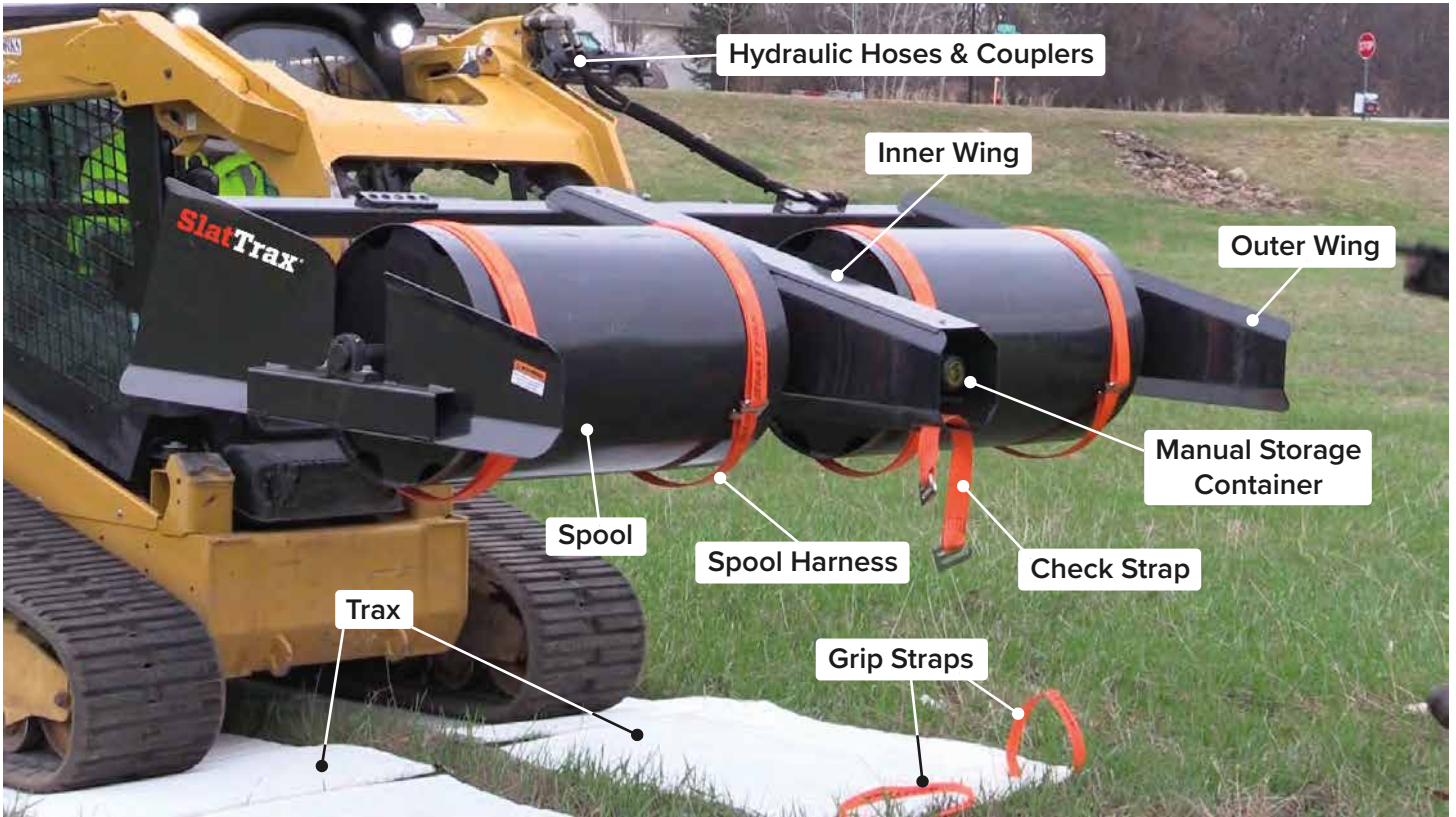

TERM

DESCRIPTION

Manual Storage Container	Hard copy of Operation and Technical Manual in this container
Hydraulic Hoses & Couplers	Standard 90° elbow male and female couplers attached to 3/8" rubber hydraulic hoses
Inner / Outer Wings	Steel wall guides to align Trax during retrieval and contain them during transport
Trax	The SlatTrax "roadway" deployed for vehicles, made from individual "Slats" and fastened together into assembled Sections
Section Strap	Full length strapping across entire length of section (12.5-foot or 25-foot lengths); Section Straps are fastened to each section and to each individual slat
Grip Strap	Used for dragging each Section into necessary ground position and for connection of one Section to the adjoining Section to solidify roadway; also connect to Spool Harness Straps on Attachments
Spool	Steel cylinders notched for mounting the Spool Harnesses
Spool Harness Strap	Straps connected to Spools, each with a buckle to secure the grip straps from lead end of sections to retrieve Trax onto the spools
Check Strap	This singular strap has two buckles to connect to the last section of Trax retrieved onto the spools so that they are secured during transport

Operation of Attachment

Installing Attachment



Figure 2

Refer to your machine's operator manual for information on how to mount the attachment, proper hydraulic hookup [Figure 2] and hydraulic operation, and how to operate the machine.

Be sure the machine is rated for this attachment.



Figure 3

When transporting / moving the attachment, raise the machine arm(s) so the attachment is above the ground and SlatTrax are not dragging on turf, roadway or other hardscape. [Figure 3]

Note: When operating, transporting or moving the attachment, a spotter/assistant should help the operator.

Trax Length

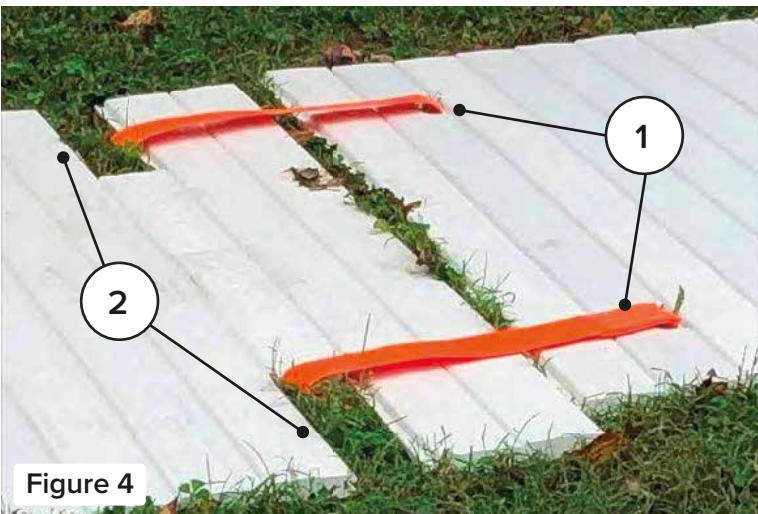

Figure 4

Standard configuration is 100 lineal feet comprised of 4-25' or 8-12.5' (DIY format) sections. The Trax may be separated in 25' or 12.5' sections as needed.

The sections are joined by grip straps (lead end) (Item 1) which loop over the opposing section recessed grip slots (tail end) (Item 2). [Figure 4]

This allows for the sections to be adjusted manually for desired Trax layout for the jobsite.

Deploying Trax

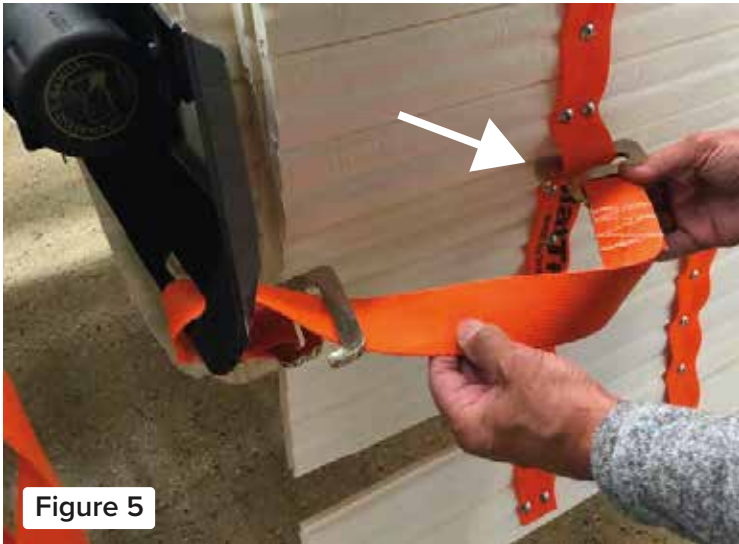

Figure 5

Always operate the SlatTrax attachment with a spotter/assistant.

Refer to your machine's operator manual for instruction on how to operate the hydraulics. The machine operator may need to rotate the spool(s) slightly to release any tension from the check strap(s).

With the machine at the location where the Trax are going to be used, the spotter/assistant will unhook the check strap(s) from the Trax roll(s). [Figure 5]



Figure 6

The operator will begin to roll out Trax by turning the spool(s) to lower the Trax to the ground.

When the Trax are contacting the ground (Item 1), drive the machine forward so the Trax are beneath the spool(s). [Figure 6]

Continue the roll out of Trax with assistance from a spotter/assistant.

Allow some slack (Item 1) as the Trax are rolled off the spool(s). Avoid "roll-back" (Item 2) of the Trax, this can cause the spines holding the slats together to break. [Figure 6]

Avoid excessive tension, caused by "pulling" the Trax off the spool(s), this can damage the Trax and/or SlatTrax attachment.

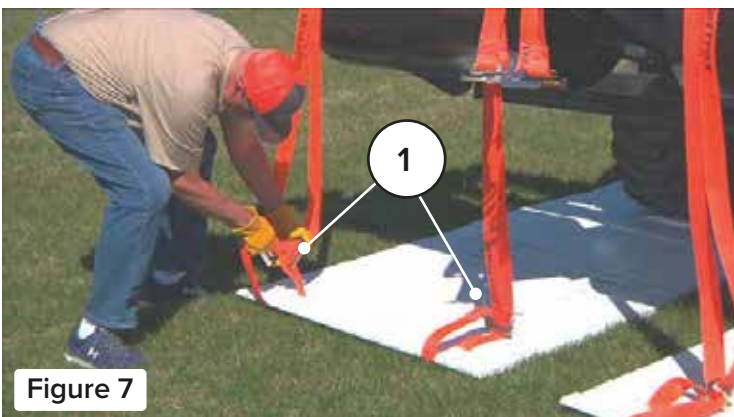

Figure 7

If the entire spool of Trax is not needed, the Trax can be separated at section joints. See "Trax Length" on page 5.

When you have reached the end of the Trax on the spool(s), stop rolling out the Trax and stop moving the machine forward. Have the spotter/assistant disconnect the grip straps from the spool harnesses (Item 1). [Figure 7]

Additional Trax can be loaded onto the spool(s) if needed. Refer to "Additional Trax" on page 20.

Retrieving Trax



Figure 8

Have the spotter/assistant help the operator align the attachment spool(s) with the Trax. The spotter/assistant can then connect the grip straps on the Trax lead end to the buckle (Item 1) on the spool harnesses. [Figure 7]

The spotter/assistant will help direct the operator while backing up to allow retrieval of 1-2 layers of Trax back onto the spool(s) and to make sure the Trax are aligned and captured inside the attachment arms. [Figure 8]



Figure 9

Stop retrieving the Trax after 1-2 layers are on the spool(s). [Figure 8]

The spotter/assistant will help direct the operator while backing up, dragging the Trax with the machine. This allows the operator to focus on backing up and also this helps to remove debris left on the Trax. [Figure 9]



Figure 10

When the operator reaches the end of a 100 foot section or at a reasonable distance, stop backing up the machine and retrieve the Trax onto the spool(s).

The spotter/assistant will continue to aid the operator by watching that the Trax are aligned and spooling properly. [Figure 10]

The spotter/assistant will signal the operator to stop when the final section of Trax is rolled up. The spotter/assistant can then install the check strap to the Trax. [Figure 5]

The Trax can then be tightened to secure for transport.

Width Adjustment on Adjustable Spread Attachment

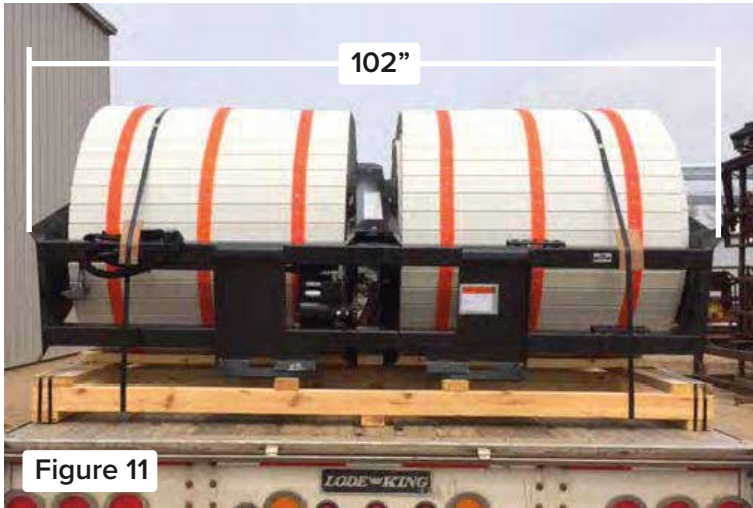

Figure 11

The Adjustable Spread Attachment allows for broader ground coverage so that larger vehicle wheels/tracks are more centered on the Trax at the worksite.

The width of the Adjustable Spread Attachment with the spools in the narrowest position (in addition to the standard 42" system) is 102" which is within DOT width limits. [Figure 11]

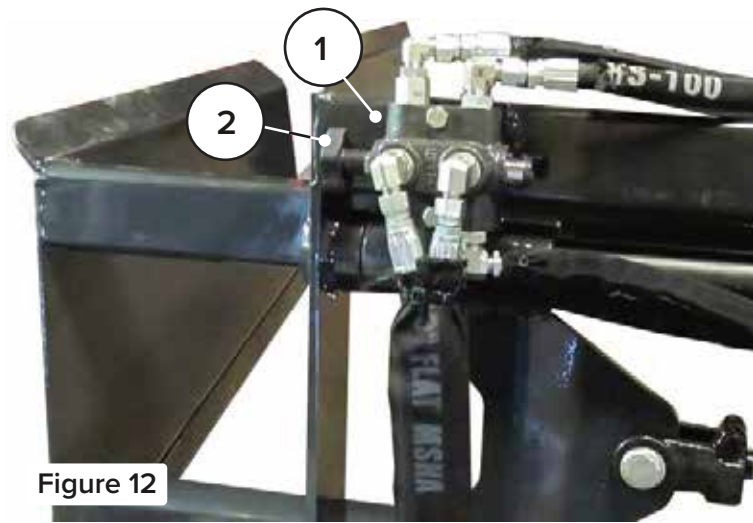

Figure 12

A selector valve (Item 1) is used to change the hydraulic functions. The valve is located on the upper left rear of the mainframe as viewed from the operator's (cab perspective) position.

[Figure 12]

To operate the rotation of the spools, the control knob (Item 2) should be pushed IN. [Figure 12]

To adjust the spread of the Trax, the control knob (Item 2) should be pulled OUT. [Figure 12]



Figure 13

See [Figure 13] for the adjustable Trax outside width dimensions.

36" Trax Width (80" Min - 104" Max Width)
42" Trax Width (92" Min - 116 Max Width)

Maintenance Items

Always replace worn or broken parts immediately after they are discovered. Do not use the SlatTrax system if any parts are not functioning properly. Inspect all mounting openings, flanges and welds before mounting attachment or when removing the attachment from the carrier.

Lubrication



Figure 14

Oil the drive chain(s) monthly or as needed.

Note: After oiling drive chain(s), be sure to wipe / clean up any accessoil that has dripped on the attachment or the ground.

Lubricate the spool bearing grease fittings (Item 1) with a good quality lithium grease every 40 hours or weekly (all models). [Figure 14]

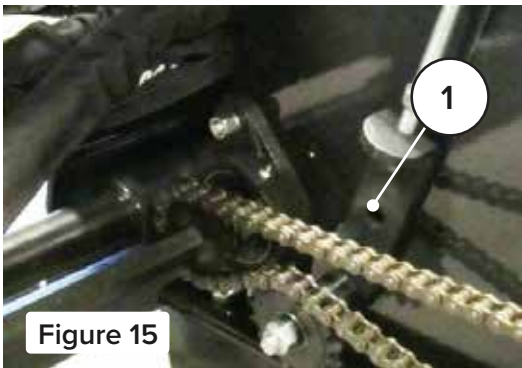

Figure 15

Lubricate the drive shaft bearing grease fittings (Item 1) with a good quality lithium grease every 40 hours or weekly (adjustable spread models only). [Figure 15]

Note: Clean grease fittings before greasing.

Note: After greasing, clean up and dispose of any purged grease.

Inspection

Always replace worn or broken parts immediately after they are discovered. Do not use the SlatTrax system if any parts are not functioning properly. Inspect all mounting openings, flanges and welds before mounting attachment or when removing the attachment from the carrier.

Drive Train Tension

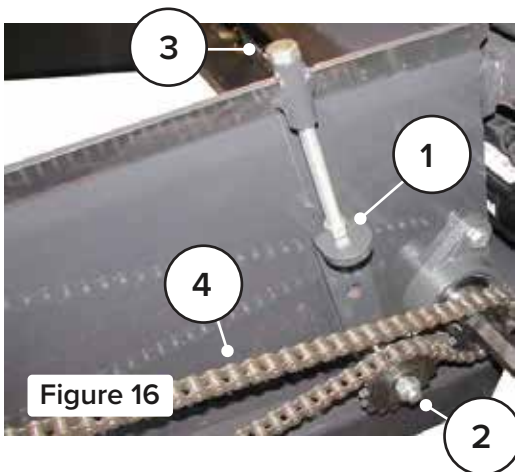

Figure 16

The following steps are used to adjust the drive chain tension.

Note: The image shown is for an adjustable spread system, but the procedure is the same for all models.

1. Remove the chain shield / cover (if needed).
2. Loosen the tensioner bolt jam nut (Item 1). [Figure 16]
3. Loosen the idler sprocket nut (Item 2). [Figure 16]
4. Turn the chain tensioner bolt (Item 3) to adjust the drive chain tension until there is only a slight deflection of the drive chain (Item 4). [Figure 16]
5. Tighten the idler sprocket nut (Item 2). [Figure 16]
6. Tighten the tensioner bolt jam nut (Item 1). [Figure 16]
7. Install the chain shield / cover (if removed).

Note: The adjustable spread system has drive chain on each spool carrier, so both drive chains will need to be adjusted.

Replacing Adapter Shaft

The adapter shaft is an extension of the shaft built in to the spools. It may be necessary to replace the spool and/or the adapter shaft itself. In either case, the adapter shaft must first be removed from the bearings.

Fixed Spread Attachment

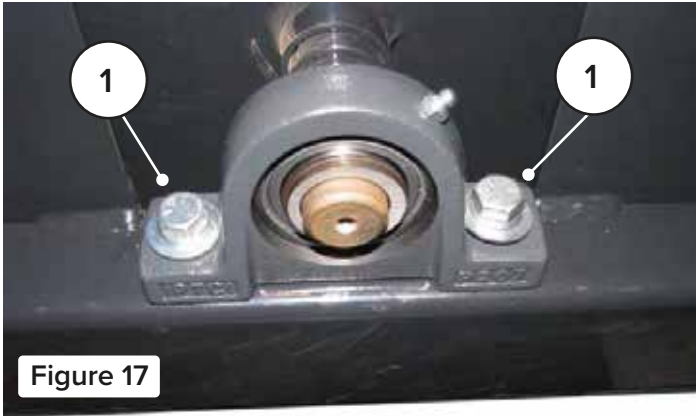

Figure 17

1. Remove the chain shield / cover.
2. Loosen drive chain tension, see “Drive Chain Tension” on page 9.
3. Attach a lifting device to the spool with the drive sprocket.
4. Remove the bearing mounting bolts (Item 1) from the opposite end of the spool with the drive sprocket. [Figure 17]
5. Lift and remove the spool from the attachment.
6. Set the spool on the ground and block to keep it from rolling.

7. Loosen the two set screws (Item 1) and remove the broken shaft from the sprocket. [Figure 18]

NOTE: If the broken shaft is unable to be removed, remove the four mounting bolts (Item 2) to remove the sprocket from the spool. The broken shaft will then be able to be driven out from the sprocket hub. Reinstall the sprocket on the spool and tighten the mounting bolts. [Figure 18]

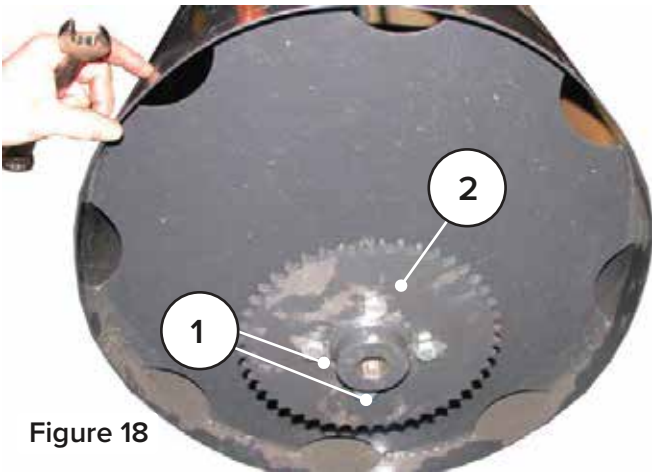

Figure 18

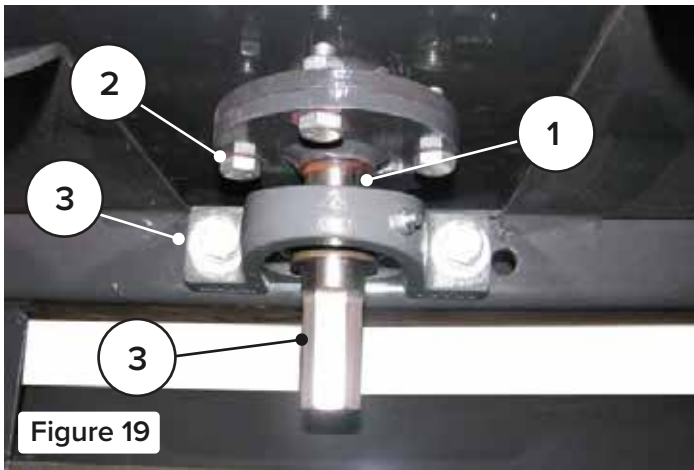

Figure 19

8. Loosen the bearing offset locking collar set screws (Item 1) and loosen the offset locking collar. [Figure 19]

9. Remove the four adapter shaft mounting bolts and nuts (Item 2). [Figure 19]

10. Remove the two bearing mounting bolts (Item 3). [Figure 19]

11. Attach a lifting device to this end of the spool and lift slightly to allow removal of the adapter shaft (Item 4) from the spool. [Figure 19]

12. Remove the bearing and offset locking collar from the adapter shaft.

13. Install the new adapter shaft (Item 1) in the spool and install and tighten the four mounting bolts (Item 2) and nuts. [Figure 20]

14. Place the offset locking collar (Item 3) and bearing (Item 4) onto the adapter shaft. [Figure 20]

15. Align the bearing mounting holes while lowering the lifting device used to raise the spool.

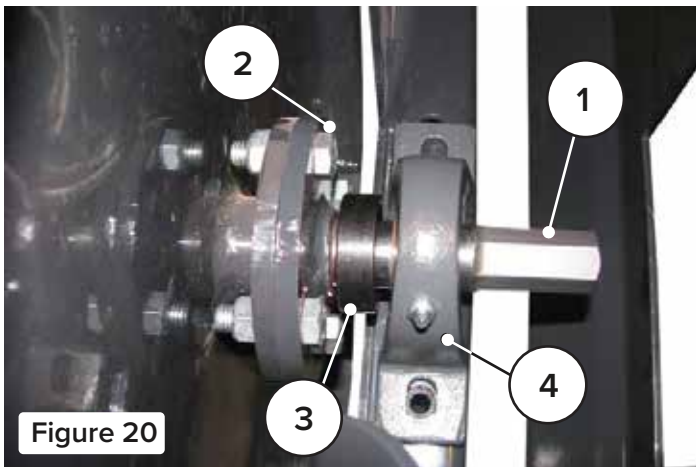

Figure 20

16. Install and tighten the bearing mounting bolts (Item 1). [Figure 21]

17. Lock bearing offset locking collar (Item 2) and tighten the set screws. [Figure 21]

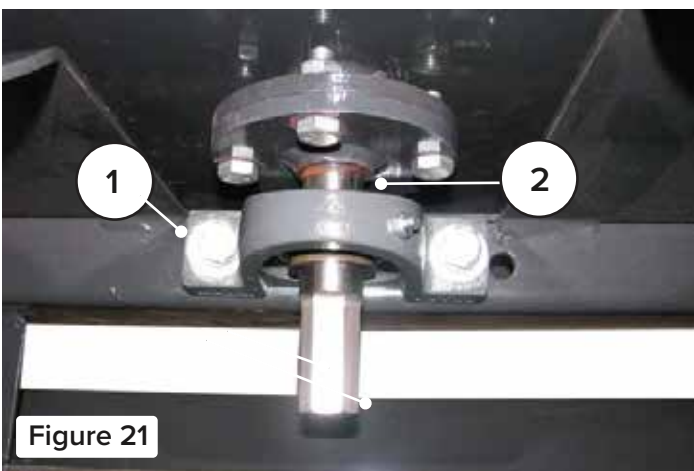

Figure 21

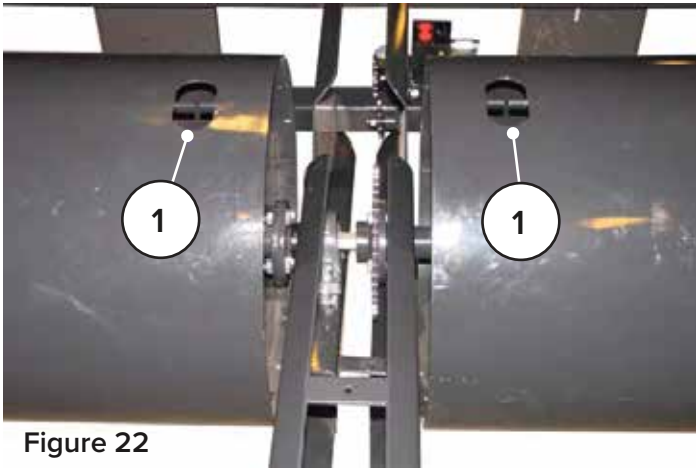

Figure 22

18. Attach a lifting device to the spool that was previously removed.

19. Lift and position the spool onto the attachment.

Note: Make sure the spool harness mounts (Item 1) are aligned. [Figure 22]

20. Slide the sprocket hub (Item 1) onto the adapter shaft (Item 2). [Figure 23]

21. Remove the lifting device from the spool.

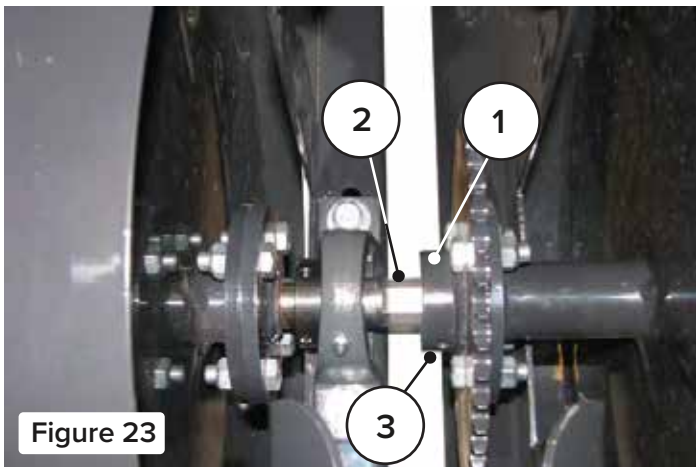

Figure 23

22. Align the bearing mount holes with the frame mount holes.

23. Install and tighten the bearing mount bolts (Item 1). [Figure 24]

24. Tighten the sprocket hub set screws (Item 3). [Figure 23]

25. Properly route the drive chain on the sprockets.

26. Adjust the drive chain tension, see "Drive Chain Tension" on page 9.

27. Reinstall the chain shield / cover.



Figure 24

Single Spool Attachment and Adjustable Spread Attachment



Figure 25

1. Remove the chain shield / cover.
2. Loosen drive chain tension, see “Drive Chain Tension” on page 9.
3. Loosen the two set screws (Item 1) and remove the broken shaft from the sprocket. [Figure 25]

NOTE: The broken shaft may need to be driven out from the sprocket hub.

4. Loosen the bearing offset locking collar set screws (Item 1) and loosen the offset locking collar. [Figure 26]

5. Remove the four adapter shaft mounting bolts and nuts (Item 2). [Figure 26]

6. Remove the two bearing mounting bolts (Item 3). [Figure 26]

7. Attach a lifting device to this end of the spool and lift slightly to allow removal of the adapter shaft (Item 4) from the spool. [Figure 26]

8. Remove the bearing and offset locking collar from the adapter shaft.

9. Install the new adapter shaft (Item 1) in the spool and install and tighten the four mounting bolts (Item 2) and nuts. [Figure 27]

10. Place the offset locking collar (Item 3) and bearing (Item 4) onto the adapter shaft. [Figure 27]

11. Align the bearing mounting holes while lowering the lifting device used to raise the spool.

12. Install and tighten the bearing mounting bolts (Item 5). [Figure 27]

13. Lock bearing offset locking collar (Item 3) and tighten the set screws. [Figure 27]

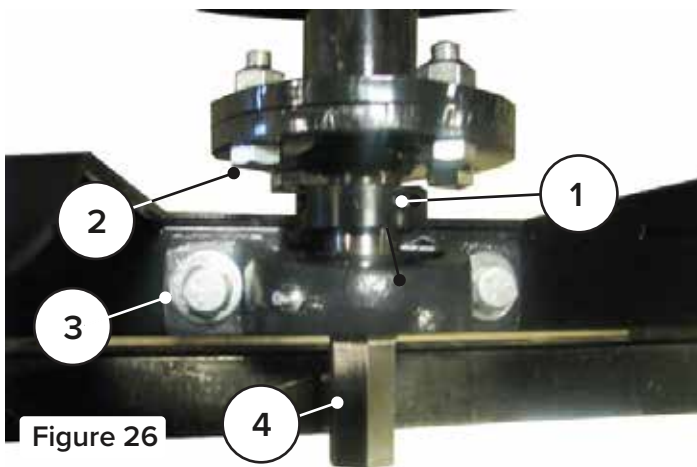

Figure 26

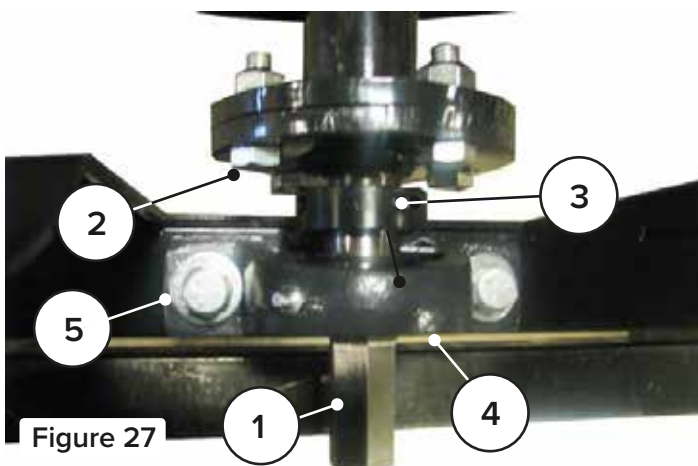
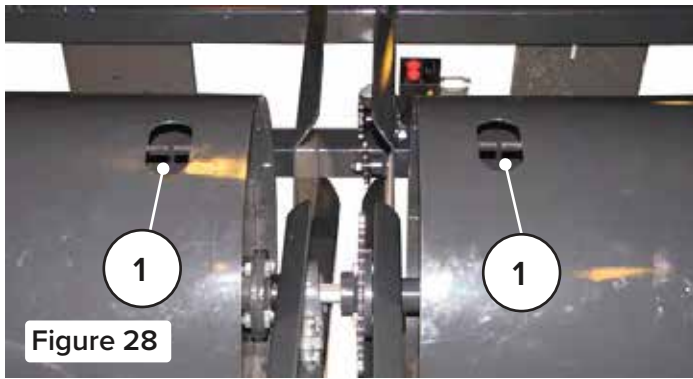

Figure 27



14. On the adjustable spread attachment, make sure the spool harness mounts (Item 1) are aligned. [Figure 28]

NOTE: The image shown does not show the adjustable spread attachment but the procedure is correct.

15. Position the sprocket (Item 1) on the spool adapter shaft. [Figure 29]

16. Properly route the drive chain on the sprockets.

17. Place a straight edge between the face of the spool sprocket and drive sprocket, adjust the spool sprocket until aligned with the drive sprocket.

18. Tighten the sprocket hub set screws (Item 3). [Figure 29]

19. Adjust the drive chain tension, see “Drive Chain Tension” on page 9.

20. Reinstall the chain shield / cover.

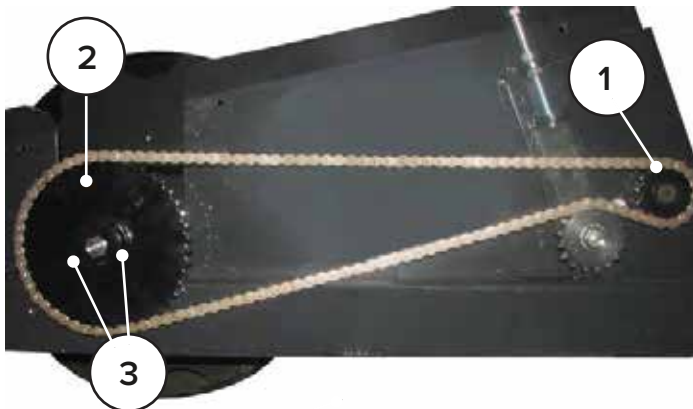

Single Spool Attachment and Adjustable Spread Attachment

Spool Bearings

To replace the spool bearings, use the same process as Replacing Adapter Shaft, skipping the steps for removing the adapter shaft from the spool.

Drive Shaft Bearings

Drive shaft bearings are only on the adjustable spread models. To aid in the removal, adjust the spools to the widest width.

NOTE: The spools have been removed from the attachment for image for clarity.

1. Remove the chain shield / cover.

2. Loosen drive chain tension, see “Drive Chain Tension” on page 9 and remove the drive chain.

3. Loosen the set screw (Item 1). [Figure 30]

4. Remove the bolt (Item 2) and remove the motor assembly (Item 3). [Figure 30]

5. Remove the bearing mounting bolts and nuts (Item 1). [Figure 31]

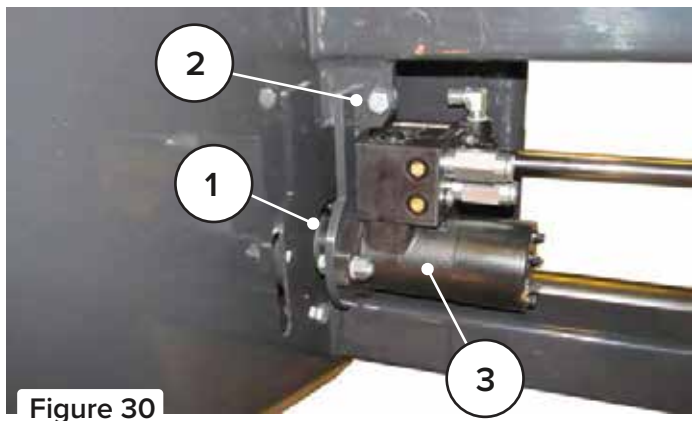

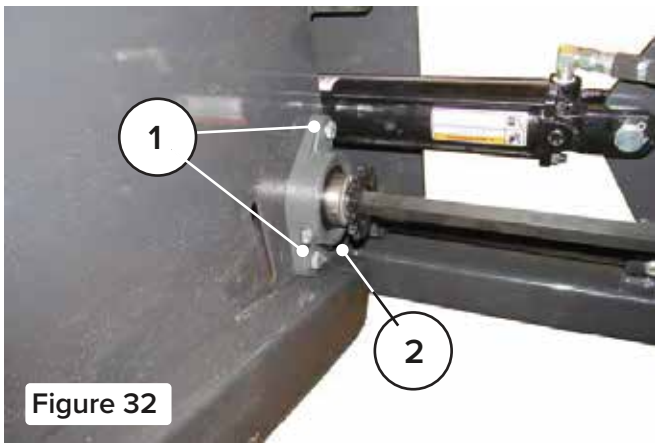

Figure 32

6. Remove the bearing mounting bolts and nuts (Item 1). [Figure 32]

7. Slide the bearing assembly (Item 2) towards the motor bearing. [Figure 32]

8. Remove the drive shaft / bearing assembly from the attachment.

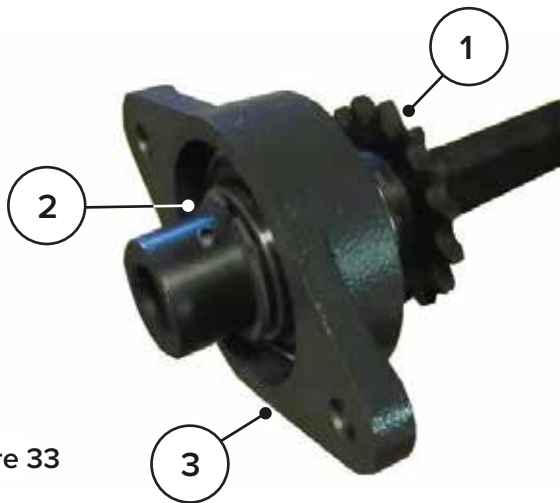

Figure 33

9. Remove the snap ring (Item 1) and remove the bearing (Item 2) from the sprocket hub / shaft assembly (Item 3). [Figure 33]

Be sure to note the orientation of the bearing, install the new bearing in the same orientation.



Figure 34

10. Remove the sliding bearing from the shaft assembly.

11. Remove the snap ring (Item 1) and remove the bearing (Item 2) from the sprocket hub (Item 3). [Figure 34]

Be sure to note the orientation of the bearing, install the new bearing in the same orientation.

12. Reverse the steps to re-install.

Fixed Spread Attachment Parts

ITEM #	DESCRIPTION	COMMON PARTS		SPECIFIC 36"		SPECIFIC: 42"		SPECIFIC: 48"	
		Part #	Qty	Part #	Qty	Part #	Qty	Part #	Qty
1	Hose Guard			2000	1	2000	1		1
2	Chain Tightner	2934	1						
3	Hose Storage Bracket	2935	1						
4	Motor Guard	3171	1						
5	Chain Guard Cover			3494	1	3710	1	3659	1
6	Document Holder	3494	1						Lorem
7	Sprocket Weldment - 35 Tooth	3484	1						
8	Fixed Spread Attachment Frame			3486	1	3160	1	3658	1
9	Right Hand Spool (Cab Perspective)			3492	1	3483	1		
10	Single Spool							3663	1
11	Left Hand Spool (Cab Perspective)			3493	1	3485	1		
12	Shaft Adapter Hub			3681	1	3685	1	3681	1
13	Idler Sprocket Spacer			3704	1	3704	1	3703	1
14	Hydraulic Couplers Short 90 Male	4000	1						
15	Hydraulic Couplers Short 90 Female	4001	1						
16	Hydraulic Hose 3/8" x 88"	4002	2						
17	Relief Valve (Dual Port)	4008	1						
18	Hydraulic Motor (22.6 ci)	4009	1						
19	Bearing Base Mount			4016	3	4016	3	4016	2
20	Sprocket Weldment - 15 Tooth	4020	1						
21	Idler Sprocket	4021	1						
22	Roller Chain #50	4025	1						
23*	Connector Link #50	4026	1						
24*	Offset Link #50	4027	1						
25	Tensioner Bolt (6" Full Thread)			4029	1	4029	1		
26	Tensioner Bolt (4" Full Thread)							4028	1
27	Spool Harness Strap w/ Buckle (6" Length)			9001	4	9001	4	9001	2
28*	Grip Strap (30" Circum/15" Length)			9002	4	9002	4	9002	2
29	Catch Strap (32" with Buckles Both Ends)	9004	1						

* - Not Shown



Adjustable Spread Attachment Parts

ITEM #	DESCRIPTION	COMMON PARTS		SPECIFIC 36"		SPECIFIC: 42"	
		Part #	Qty	Part #	Qty	Part #	Qty
1	Chain Tightner	2934	2				
2	Hose Storage Bracket	2935	1				
3	Hose Guard	3146	1				
4	Chain Guard Cover	3166	1				
5	Motor Guard	3171	1				
6	Motor Mount	3271	1				
7	Idler Sprocket Spacer	3288	2				
8	Motor Drive	3302	1				
9	Drive Hub	3689	1				
10	Adjustable Spread Attachment Frame			3317	1	3147	1
11	Document Holder	3443	1				
12	Sprocket Weldment - 35 Tooth	3484	2				
13	Shaft Slide for Adjustable Spread Frame			3488	4	3148	4
14	Adjustable Spread Spool			3534	2	3533	2
15	Shaft Adapter Hub	3681	2				
16*	Hydraulic Couplers Short 90 Male	4000	1				
17*	Hydraulic Couplers Short 90 Female	4001	1				
18	Hydraulic Hose 3/8" x 88" (Directional valve to skid loader)	1002	2				
19	Hydraulic Hose 3/8" x 25" (Bottom of divider combiner to rod end of cylinders)	4006	2				
20	Hydraulic Hose 3/8" x 11" (Branch tee in cylinder to base end of cylinder)	4007	1				
21	Relief Valve (Dual Port)	4008	1				
22	Hydraulic Motor (22.6 ci)	4009	1				
23*	Connector Link #50			4032	1	4033	1
24	Bearing - Base Mount	4016	4				
25	Bearing - Flange Mount	4017	2				
26	Left Hand Drum Frame (Cab Pespectivce)	4027		4018	1	3155	1
27	Right Hand Drum Frame (Cab Perspective) 4019 1			4019	1	3156	1
28	Idler Sprocket	4021	2				
29	Hydraulic Hose (Top of directional valve to motor)			4022	2	4003	2
30	Hydraulic Hose (Bottom right of directional valve to top of the divider combiner valve)			4023	1	4004	1
31	Hydraulic Hose (Bottom left of directional valve to branch tee in cylinder)			4024	2	4005	2
32	Roller chain #50	4025	1				
33*	Connector link #50	4026	1				
34*	Offset link #50	4027	1				
35	Tensioner bolt (6" Full Thread)	4029	2				
36	Divider combiner valve	4030	1				
37	Selector Valve	4031	1				
38*	Spool Harness Strap w/ Buckle (6' Length) 9001 4	9001	4				
39*	Grip Strap (30" Circum/15" Length)	9002	4				
40*	Catch Strap (32" with Buckles Both Ends)	9004	2				

* - Not Shown

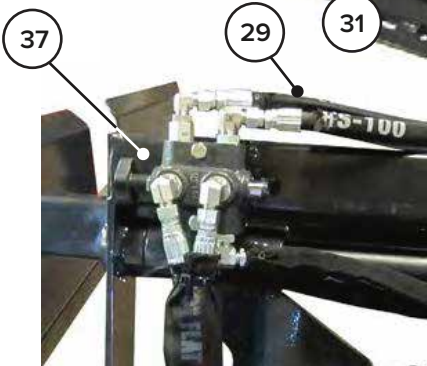
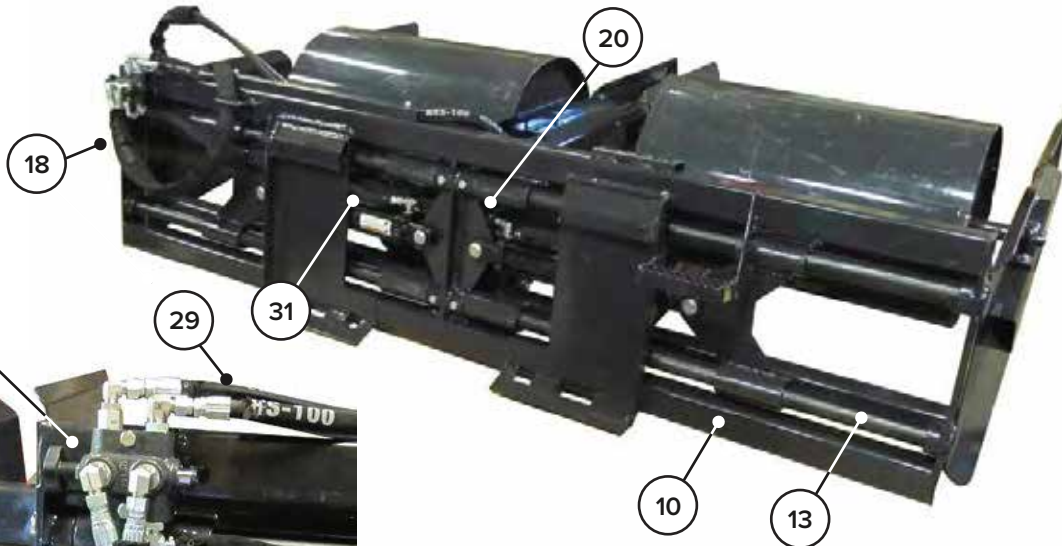
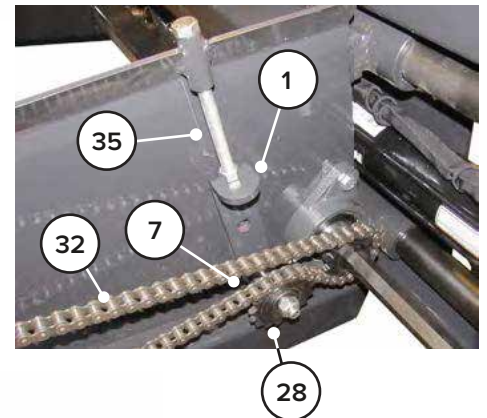
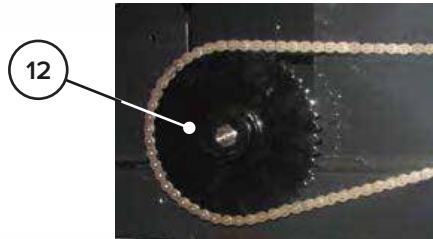
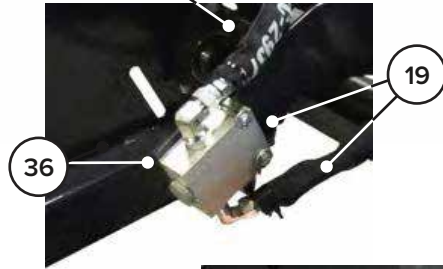
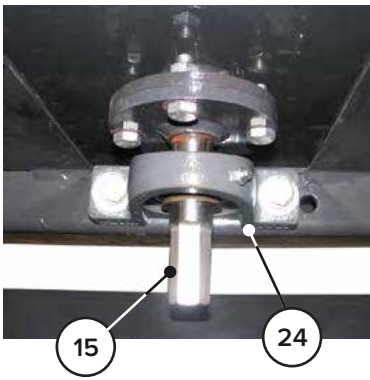
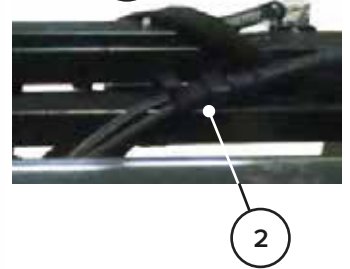
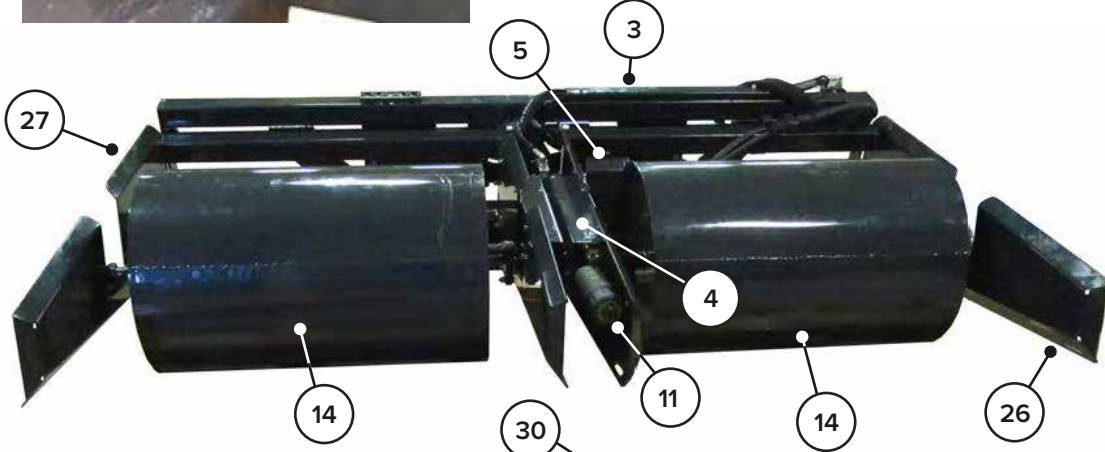
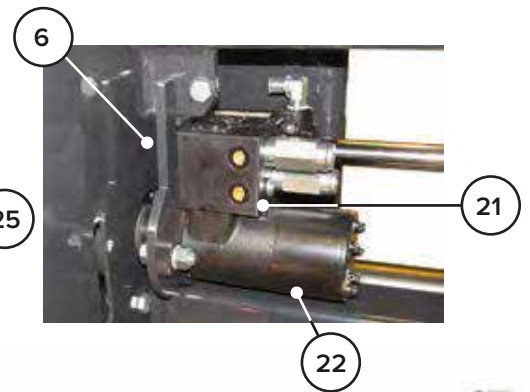
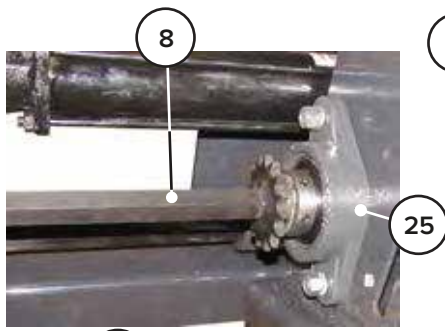
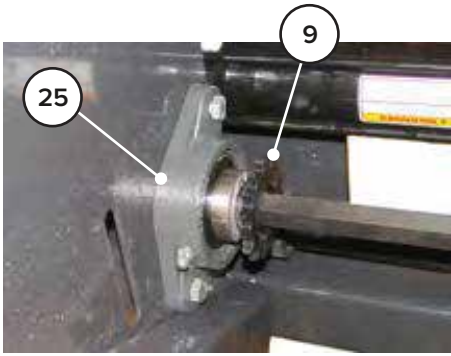

Manual Handling of Trax



Manually maneuver the Trax into positions necessary for various vehicles, etc. including adjusting the curvature of the Trax. [Figure 35]



Be sure to connect sections after manually maneuvering the Trax to stabilize and strengthen roadway. [Figure 36]



It may be necessary to stabilize the Trax when used on uneven terrain. To secure the Trax, drill holes in the Trax and insert spikes through the holes. [Figure 37]



Additional Trax

When additional Trax are needed to extend temporary roadways, Trax are available in rolls or on pallets holding foldable, stackable Trax (DIY format). [Figure 38]