

ALUMINUM TRUCK DOCKBOARD WITH STEEL SAFETY CURB - TAS-10-6036

APPROX WEIGHT: 104.32 lbs.
 DOES NOT INCLUDE WEIGHT OF POWER OR PACKAGING!!!

*** ANY ADDITIONS, DELETIONS, OR OMISSIONS MUST BE CORRECTED ON THIS DRAWING AS THIS DRAWING WILL BE CONSIDERED ALL INCLUSIVE ***
 ALL GRAPHICS PROVIDED ARE FOR REFERENCE ONLY. IF CERTAIN DIMENSIONS ARE CRITICAL PLEASE VERIFY THOSE DIMENSIONS WITH YOUR SALESPERSON

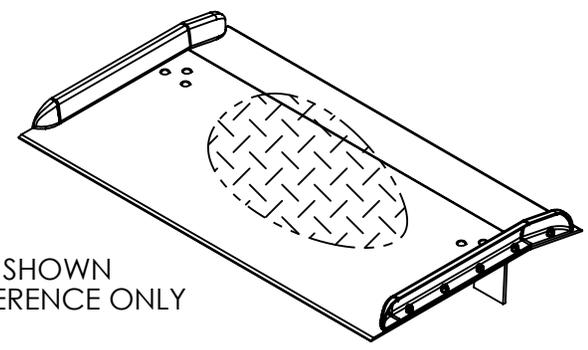
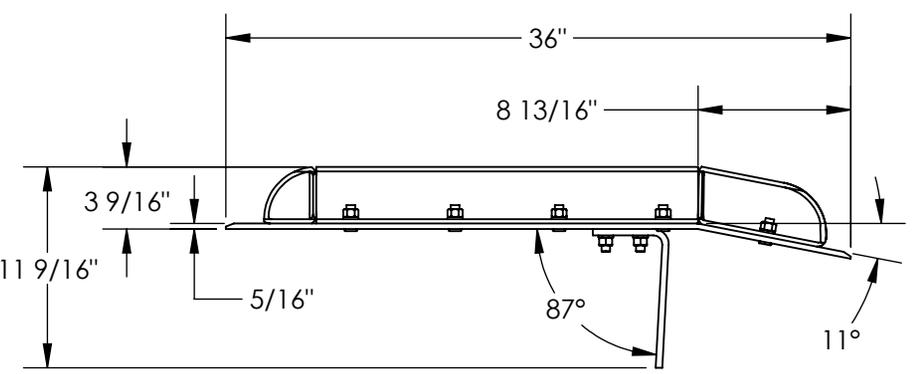
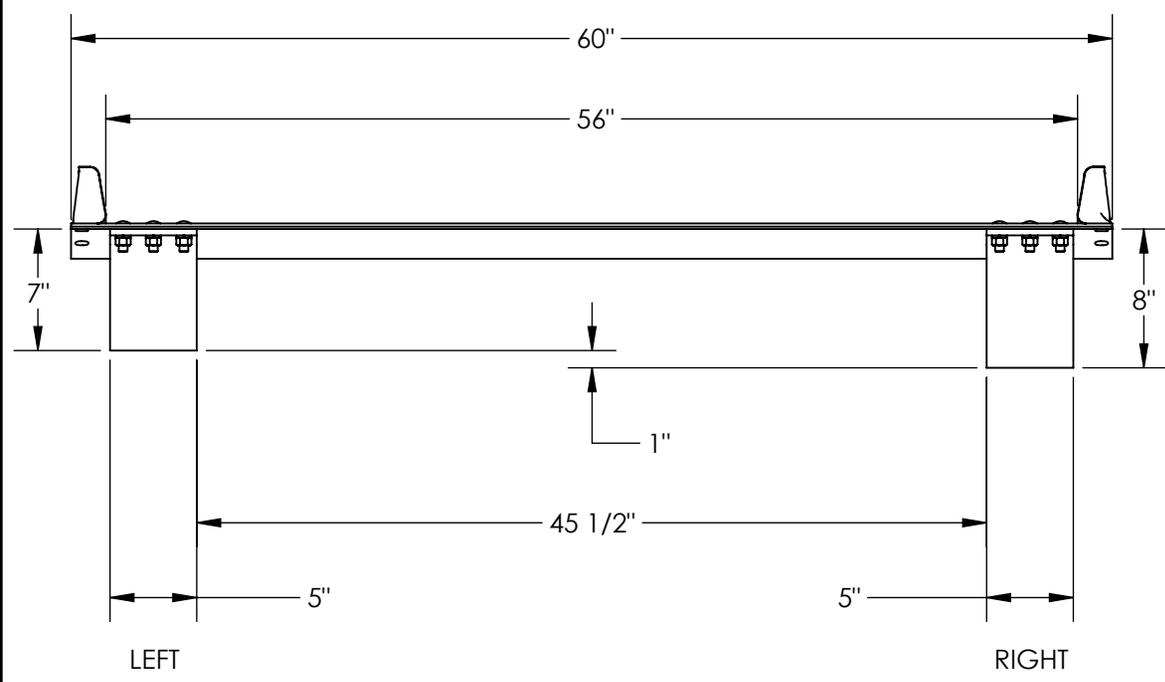

3D VIEW SHOWN FOR REFERENCE ONLY

LEGS: RIGHT LEG IS 8" LG, LEFT LEG IS 7" LG. LEGS ARE UNEVEN TO CREATE A GAP SO DOCKBOARD CAN BE PICKED UP BY A FORK LIFT

STANDARD FEATURES

- MODEL NUMBER IS: TAS-10-6036
- MAX CAPACITY IS: 10,000 LBS
- OVERALL WIDTH IS: 60"
- USABLE WIDTH IS: 56"
- OVERALL LENGTH IS: 36"
- USABLE LENGTH IS: 36"
- OVERALL HEIGHT IS: 11 9/16"
- DOCKPLATE THICKNESS: 5/16"
- CROWN IS 11° & 8 13/16" FROM EDGE
- HEIGHT DIFFERENCE IS: 5"
- ALUMINUM CONSTRUCTION WITH BOLT-ON STEEL CURBS

SPECIAL FEATURES

NONE

DIMENSION TOLERANCE ± 1/4"

A P P R O V A L	I, THE UNDERSIGNED, AGREE THAT THE PRODUCT AS REPRESENTED SATISFIES DESIGN AND DIMENSION REQUIREMENTS. I ALSO ACKNOWLEDGE MY DUTY TO CONFIRM PRODUCT AND INSTALLATION COMPLIANCE WITH ALL APPLICABLE FEDERAL, STATE AND LOCAL REGULATIONS AND STANDARDS.	
	UNITS REQUIRING APPROVAL DRAWINGS OR MODIFIED ARE NON-RETURNABLE	
	[] As drawn [] As marked	
	Signed: _____	Date: _____
Printed Name: _____		
<i>LEAD TIME WILL START UPON RECEIPT OF SIGNED APPROVAL DRAWING</i>		

DISTRIBUTOR'S NAME:		P.O.#
VESTIL MANUFACTURING		X
DRAWN BY: MTS		DATE: 09/11/2014
REFERENCE: X		SCALE: 1:11
QUOTED LEAD TIME: X		QUOTE # X
		SALES: X
		FILE NAME: 11-007-032