

# ALUMINUM TRUCK DOCKBOARD WITH STEEL SAFETY CURB - TAS-20-6060

APPROX WEIGHT: 251.03 lbs.  
 DOES NOT INCLUDE WEIGHT OF POWER OR PACKAGING!!!

\*\*\* ANY ADDITIONS, DELETIONS, OR OMISSIONS MUST BE CORRECTED ON THIS DRAWING AS THIS DRAWING WILL BE CONSIDERED ALL INCLUSIVE \*\*\*  
 ALL GRAPHICS PROVIDED ARE FOR REFERENCE ONLY. IF CERTAIN DIMENSIONS ARE CRITICAL PLEASE VERIFY THOSE DIMENSIONS WITH YOUR SALESPERSON

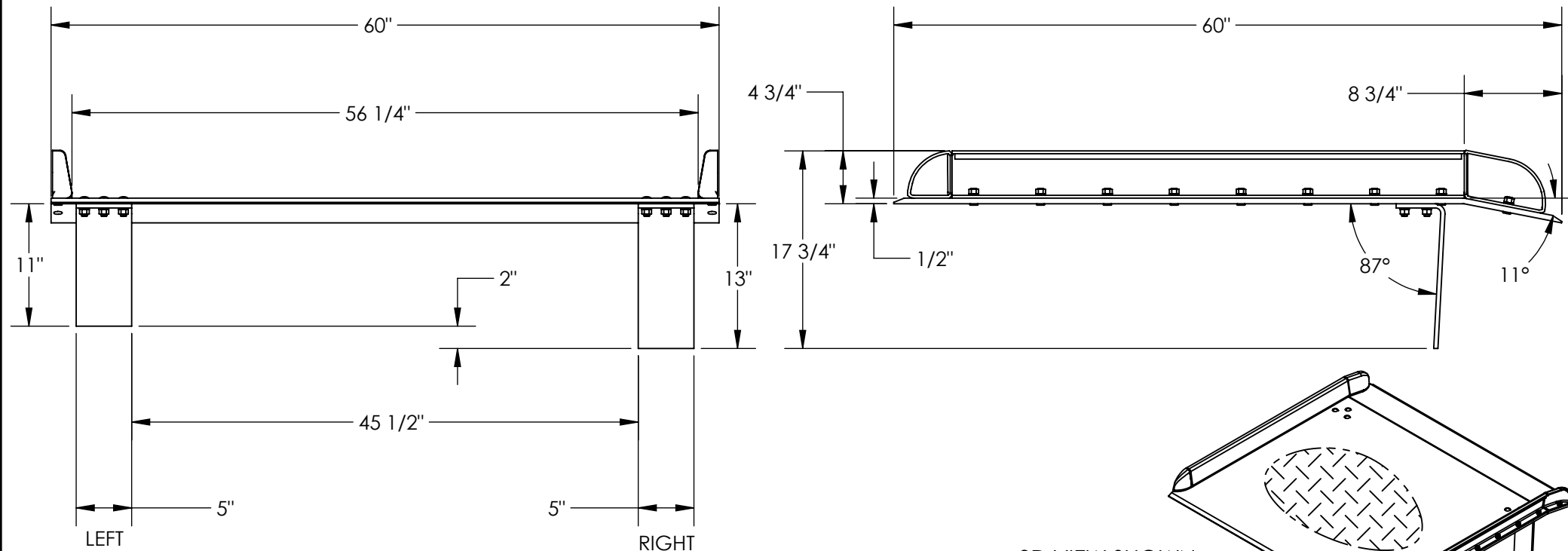

3D VIEW SHOWN FOR REFERENCE ONLY

**LEGS:** RIGHT LEG IS 13" LG, LEFT LEG IS 11" LG. LEGS ARE UNEVEN TO CREATE A GAP SO DOCKBOARD CAN BE PICKED UP BY A FORK LIFT

## STANDARD FEATURES

- MODEL NUMBER IS: TAS-20-6060
- MAX CAPACITY IS: 20,000 LBS
- OVERALL WIDTH IS: 60"
- USABLE WIDTH IS: 56 1/4"
- OVERALL LENGTH IS: 60"
- USABLE LENGTH IS: 60"
- OVERALL HEIGHT IS: 17 3/4"
- DOCKPLATE THICKNESS: 1/2"
- CROWN IS 11° & 8 3/4" FROM EDGE
- HEIGHT DIFFERENCE IS: 10"
- ALUMINUM CONSTRUCTION WITH BOLT-ON STEEL CURBS

## SPECIAL FEATURES

NONE

DIMENSION TOLERANCE ± 1/4"

APPROVAL

I, THE UNDERSIGNED, AGREE THAT THE PRODUCT AS REPRESENTED SATISFIES DESIGN AND DIMENSION REQUIREMENTS. I ALSO ACKNOWLEDGE MY DUTY TO CONFIRM PRODUCT AND INSTALLATION COMPLIANCE WITH ALL APPLICABLE FEDERAL, STATE AND LOCAL REGULATIONS AND STANDARDS.  
**UNITS REQUIRING APPROVAL DRAWINGS OR MODIFIED ARE NON-RETURNABLE**  
 As drawn     As marked

Signed: \_\_\_\_\_ Date: \_\_\_\_\_

Printed Name: \_\_\_\_\_

LEAD TIME WILL START UPON RECEIPT OF SIGNED APPROVAL DRAWING

DISTRIBUTOR'S NAME:		P.O.#
VESTIL MANUFACTURING		X
DRAWN BY: ALH		W.O.#
DATE: 06/23/2011		X
REFERENCE: X	SCALE: 1:13	SALES: X
QUOTED LEAD TIME: X	QUOTE #	FILE NAME:
	X	11-007-048