

REVISIONS				
ECR	REV.	DESCRIPTION	DATE	INITIAL
	A	CONVERTED TO SOLIDWORKS	6/10/2008	WS

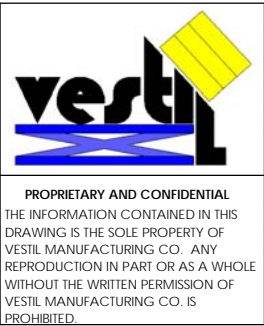
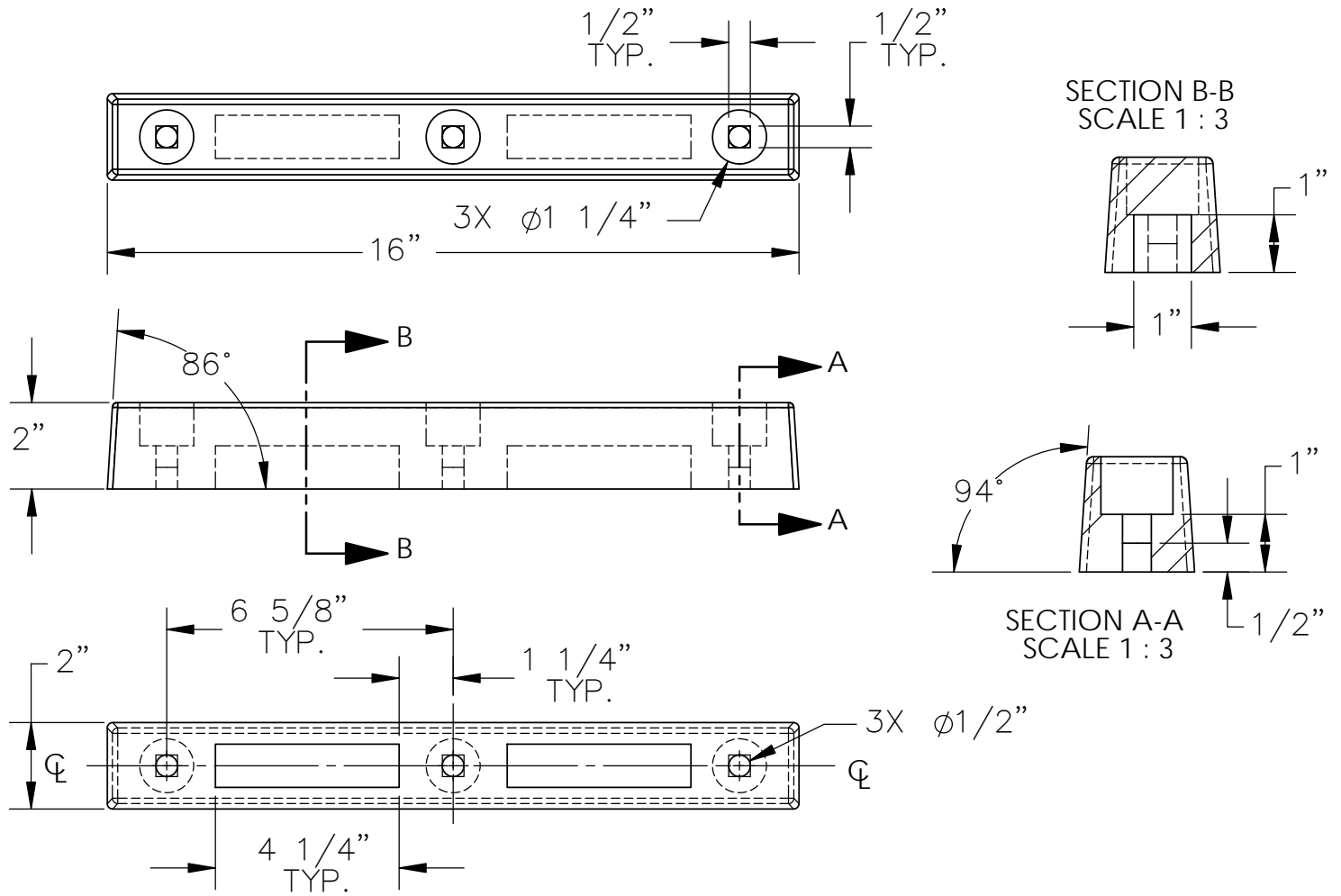

UNLESS OTHERWISE SPECIFIED: REMOVE ALL BURRS AND SHARP EDGES		
DIMENSIONS ARE IN INCHES		
CONCENTRIC	.006 TIR	.060 TIR
ANGLES	$\pm 0^{\circ} 30'$	$\pm 1^{\circ} 0'$
	x.xxx $\pm .005$	
	x.xx $\pm .010$	
DECIMALS	x.x $\pm .025$	$\pm .015$
FRACTIONS	$\pm 1/32$	$\pm 1/16$
TOLERANCES	MACHINE	WELDMENT
COMMENTS:		
DO NOT SCALE DRAWING		

**Vestil Manufacturing Co.**

DESCRIPTION:  
**BUMPER, RUBBER**

PRODUCT NO: TB-70

DRAWN BY: W. STALEY	DATE: 6/10/08	SCALE: 1:4	SIZE <b>A</b>
------------------------	------------------	------------	------------------

MAT'L: MOLDED RUBBER

SHEET 1 OF 1	DWG. NO. <b>29-048-061</b>	REV <b>A</b>
--------------	-------------------------------	-----------------