

# TOOL BALANCERS - TBR-1

APPROX WEIGHT: 1 lbs.  
DOES NOT INCLUDE WEIGHT OF POWER OR PACKAGING!!!

\*\*\* ANY ADDITIONS, DELETIONS, OR OMISSIONS MUST BE CORRECTED ON THIS DRAWING AS THIS DRAWING WILL BE CONSIDERED ALL INCLUSIVE \*\*\*

ALL GRAPHICS PROVIDED ARE FOR REFERENCE ONLY. IF CERTAIN DIMENSIONS ARE CRITICAL PLEASE VERIFY THOSE DIMENSIONS WITH YOUR SALESPERSON

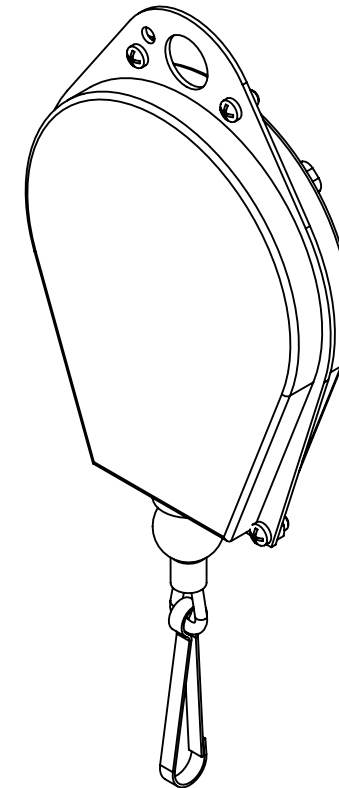
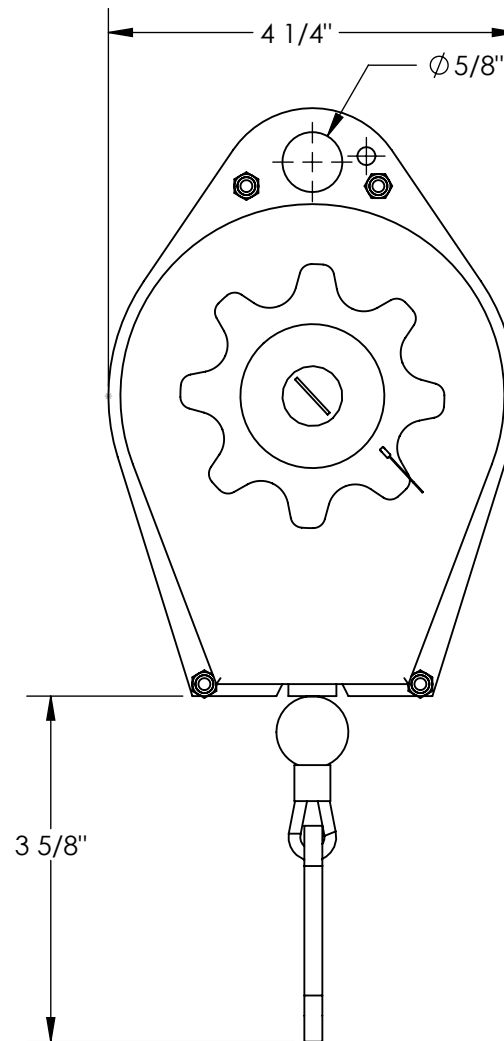
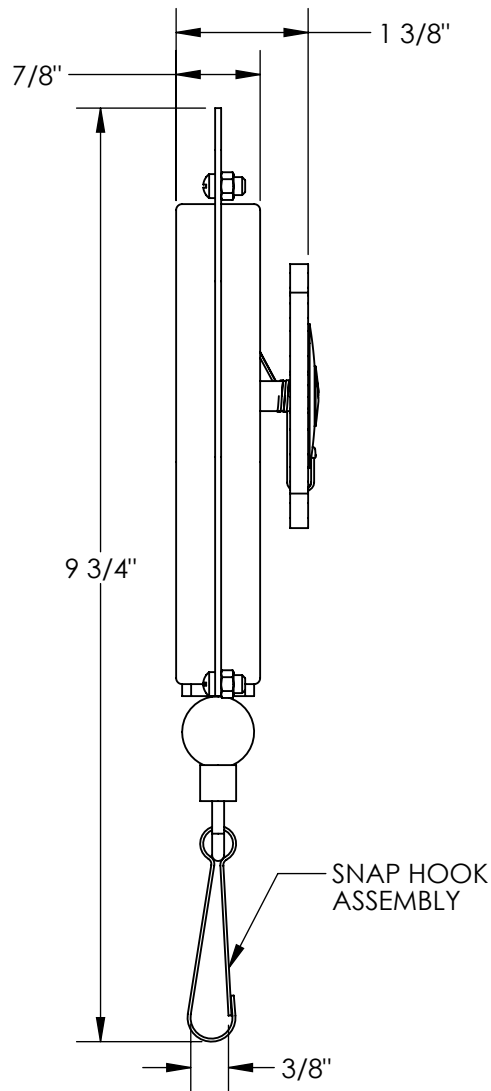

## STANDARD FEATURES

- MODEL NUMBER IS TBR-1
- OVERALL WIDTH IS 4 1/4"
- OVERALL DEPTH IS 1 3/8"
- CABLE LENGTH = 4' (INCLUDING SNAP HOOK ASSEMBLY)
- OVERALL LENGTH WHEN CABLE IS NOT EXTENDED = 9 3/4"
- OVERALL LENGTH WHEN CABLE IS EXTENDED = 54 1/8"
- MAX CAPACITY IS 3 LBS.

## SPECIAL FEATURES

NONE

**A P P R O V A L**

I, THE UNDERSIGNED, AGREE THAT THE PRODUCT AS REPRESENTED SATISFIES DESIGN AND DIMENSION REQUIREMENTS. I ALSO ACKNOWLEDGE MY DUTY TO CONFIRM PRODUCT AND INSTALLATION COMPLIANCE WITH ALL APPLICABLE FEDERAL, STATE AND LOCAL REGULATIONS AND STANDARDS.

**ALL SPECIAL UNITS ARE NON-RETURNABLE**

[ ] As drawn [ ] As marked

Signed: \_\_\_\_\_ Date: \_\_\_\_\_

LEAD TIME WILL START UPON RECEIPT OF SIGNED APPROVAL DRAWING

DISTRIBUTOR'S NAME:		P.O.#
VESTIL MANUFACTURING		X
DRAWN BY: CRM	DATE: 06/29/2011	W.O.#
REFERENCE: X	SCALE: 1:2	X
QUOTED LEAD TIME: X	QUOTE #	SALES: X
	X	FILE NAME:
		30-007-219