

# UNIVERSAL TRASH CAN DUMPER - TCD-U-72-DC

APPROX WEIGHT: 877.89 lbs.  
DOES NOT INCLUDE WEIGHT OF POWER OR PACKAGING!!!

\*\*\* ANY ADDITIONS, DELETIONS, OR OMISSIONS MUST BE CORRECTED ON THIS DRAWING AS THIS DRAWING WILL BE CONSIDERED ALL INCLUSIVE \*\*\*

ALL GRAPHICS PROVIDED ARE FOR REFERENCE ONLY. IF CERTAIN DIMENSIONS ARE CRITICAL PLEASE VERIFY THOSE DIMENSIONS WITH YOUR SALESPERSON

## STANDARD FEATURES

- MODEL NUMBER: TCD-U-72-DC
- USABLE CHUTE WIDTH: 34"
- USABLE CHUTE LENGTH: 35-7/8"
- OVERALL LENGTH: 87-5/8"
- OVERALL WIDTH: 46-1/16"
- OVERALL HEIGHT: 90-1/16"
- OVERALL ROTATED HEIGHT: 161-1/16"
- MAXIMUM ROTATED ANGLE: 45°
- DUMP HEIGHT: 72"
- WORKS WITH TRASH CANS OF
  - 17 1/2" TO 34" WIDTH
  - 20 1/2" TO 35 7/8" LENGTH
  - 27" TO 50" HEIGHT
- UNIFORM CAPACITY IS 400 LBS
- CASTERS:
  - FRONT: 8" X 2" GFN SWIVEL
  - REAR: 8" X 2" GFN RIGID
- TWO ADJUSTABLE FLOOR LOCKS
- INTERNAL POWER UNIT: 12V DC WITH ON-BOARD CHARGER
- 2 BUTTON NEMA 4 HAND PENDANT CONTROL W/ 8 FOOT COIL CORD

FRAME: DURABLE LIQUID PAINT BLUE FINISH  
CHUTE: TOUGH BAKED IN POWDER COATED YELLOW FINISH

## SPECIAL FEATURES

NONE

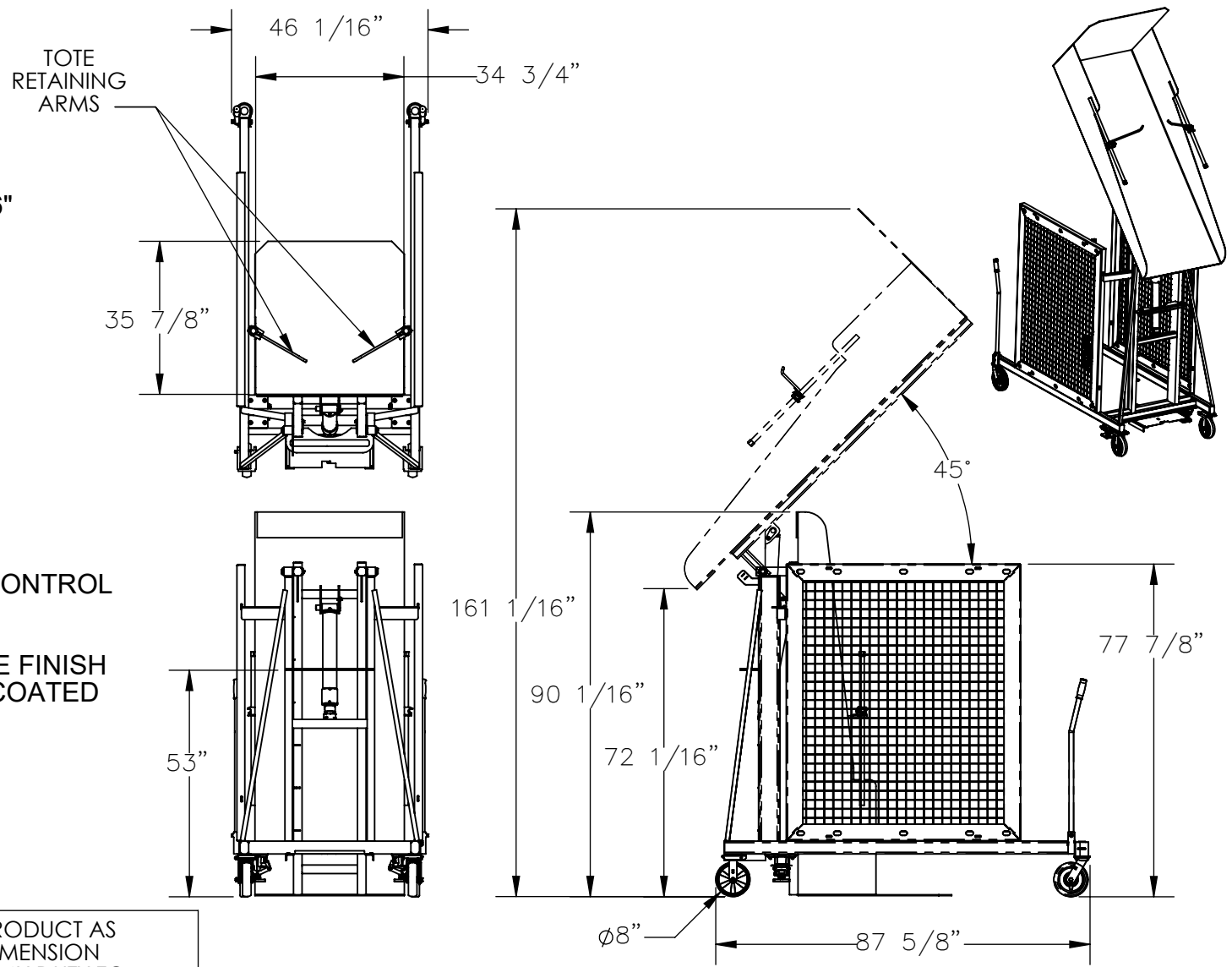

DIMENSION TOLERANCE ± 1/4"

APPROVAL

I, THE UNDERSIGNED, AGREE THAT THE PRODUCT AS REPRESENTED SATISFIES DESIGN AND DIMENSION REQUIREMENTS. I ALSO ACKNOWLEDGE MY DUTY TO CONFIRM PRODUCT AND INSTALLATION COMPLIANCE WITH ALL APPLICABLE FEDERAL, STATE AND LOCAL REGULATIONS AND STANDARDS.

**UNITS REQUIRING APPROVAL DRAWINGS OR MODIFIED ARE NON-RETURNABLE**

As drawn       As marked

Signed: \_\_\_\_\_ Date: \_\_\_\_\_

Printed Name: \_\_\_\_\_

LEAD TIME WILL START UPON RECEIPT OF SIGNED APPROVAL DRAWING

DISTRIBUTOR'S NAME: <b>VESTIL MANUFACTURING</b>		P.O.# X
DRAWN BY: SJA		DATE: 7/23/2016
REFERENCE: X	SCALE: 1:38	SALES: X
QUOTED LEAD TIME: X	QUOTE # X	FILE NAME: 34-007-035