

TILT MASTER - TM-20-AIR

APPROX WEIGHT: 621 lbs.
DOES NOT INCLUDE WEIGHT OF POWER OR PACKAGING!!!

*** ANY ADDITIONS, DELETIONS, OR OMISSIONS MUST BE CORRECTED ON THIS DRAWING AS THIS DRAWING WILL BE CONSIDERED ALL INCLUSIVE ***
ALL GRAPHICS PROVIDED ARE FOR REFERENCE ONLY. IF CERTAIN DIMENSIONS ARE CRITICAL PLEASE VERIFY THOSE DIMENSIONS WITH YOUR SALESPERSON

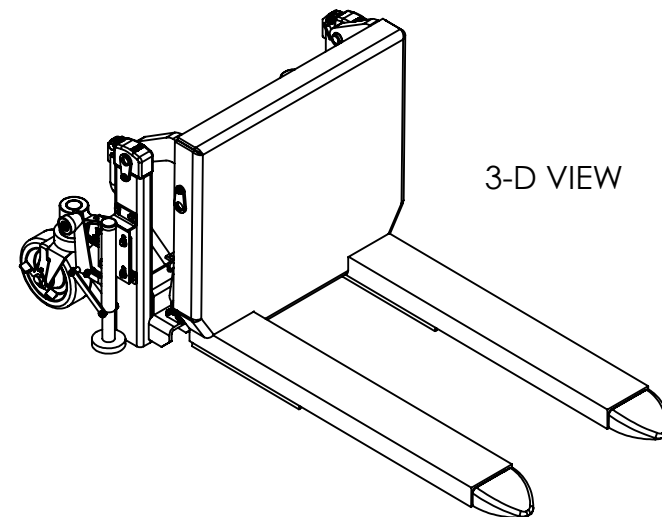
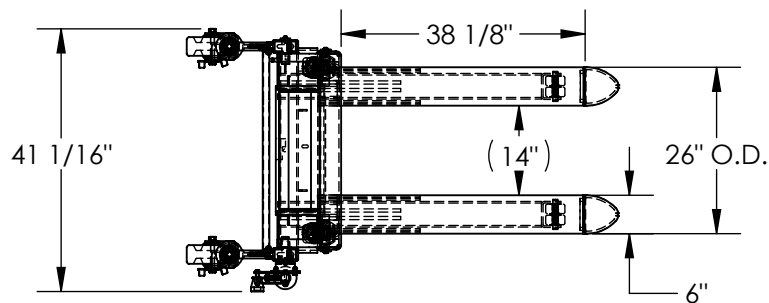

3-D VIEW

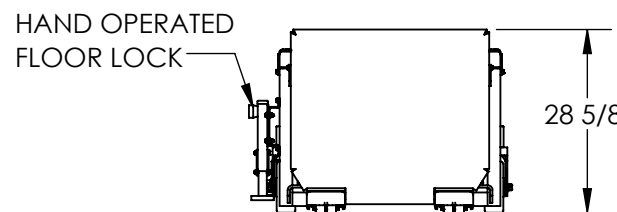
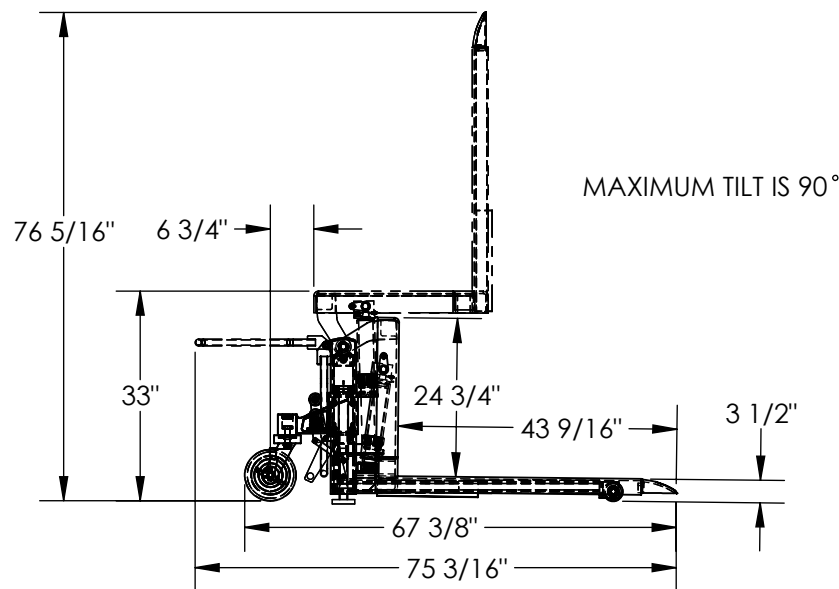

DIMENSION TOLERANCE ± 1/4"

APPROVAL

I, THE UNDERSIGNED, AGREE THAT THE PRODUCT AS REPRESENTED SATISFIES DESIGN AND DIMENSION REQUIREMENTS. I ALSO ACKNOWLEDGE MY DUTY TO CONFIRM PRODUCT AND INSTALLATION COMPLIANCE WITH ALL APPLICABLE FEDERAL, STATE AND LOCAL REGULATIONS AND STANDARDS.
UNITS REQUIRING APPROVAL DRAWINGS OR MODIFIED ARE NON-RETURNABLE
[] As drawn [] As marked

Signed: _____ Date: _____

Printed Name: _____

LEAD TIME WILL START UPON RECEIPT OF SIGNED APPROVAL DRAWING

DISTRIBUTOR'S NAME:		P.O.#
VESTIL MANUFACTURING		X
DRAWN BY: MTS		DATE: 6/22/2015
REFERENCE: X		SCALE: 1:30
QUOTED LEAD TIME: X		QUOTE # X
		SALES: X
		FILE NAME: 38-007-037

STANDARD FEATURES

- MODEL NUMBER IS TM-20-AIR
- CAPACITY IS 2,000 lbs
- OVERALL WIDTH IS 41 1/16"
- OVERALL LENGTH IS 75 3/16"
- OVERALL HEIGHT IS 76 5/16"
- ROTATED HEIGHT IS 33"
- LEVEL HEIGHT IS 28 5/8"
- FORK WIDTH IS 6"
- LOWERED FORK HEIGHT IS 3 1/2"
- USABLE FORK LENGTH IS 38 1/8"
- FORK ADJUSTMENT FIXED AT 26"
- INCLUDES HAND OPERATED FLOOR LOCK
- AIR/OIL POWERED:
 - RECIPROCATING AIR
 - POWERED HYDRAULIC
 - 15 CFM @ 100 PSI (1/4 GPM)
- FOOT TREADLE OPERATION
- DURABLE LIQUID PAINT BLUE FINISH

SPECIAL FEATURES

NONE