

TILT MASTER - TM-60-AC

APPROX WEIGHT: 739 lbs.
 DOES NOT INCLUDE WEIGHT OF POWER OR PACKAGING!!!

*** ANY ADDITIONS, DELETIONS, OR OMISSIONS MUST BE CORRECTED ON THIS DRAWING AS THIS DRAWING WILL BE CONSIDERED ALL INCLUSIVE ***
 ALL GRAPHICS PROVIDED ARE FOR REFERENCE ONLY. IF CERTAIN DIMENSIONS ARE CRITICAL PLEASE VERIFY THOSE DIMENSIONS WITH YOUR SALESPERSON

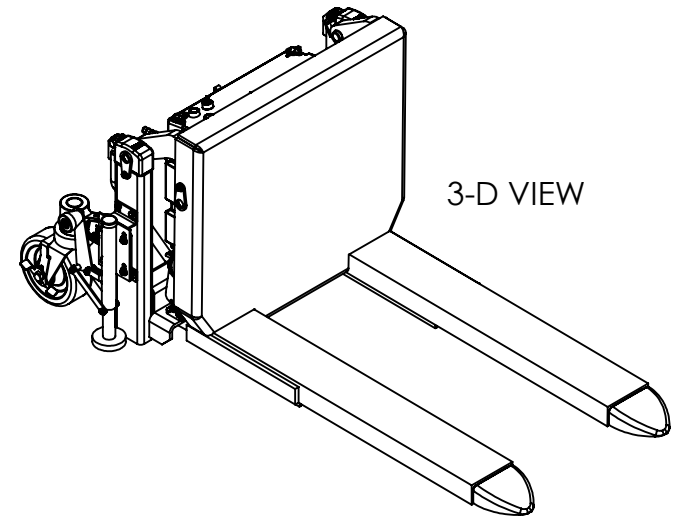
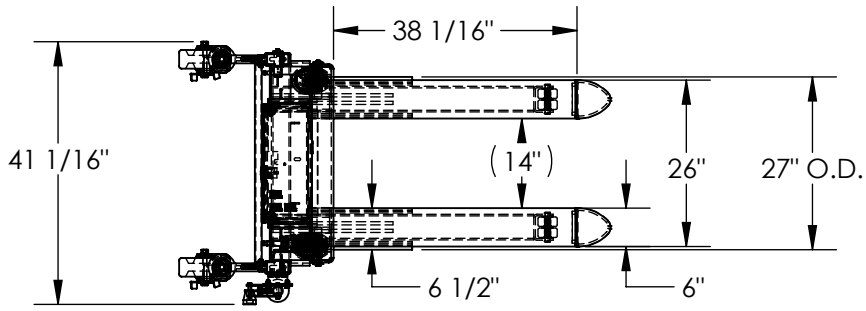

3-D VIEW

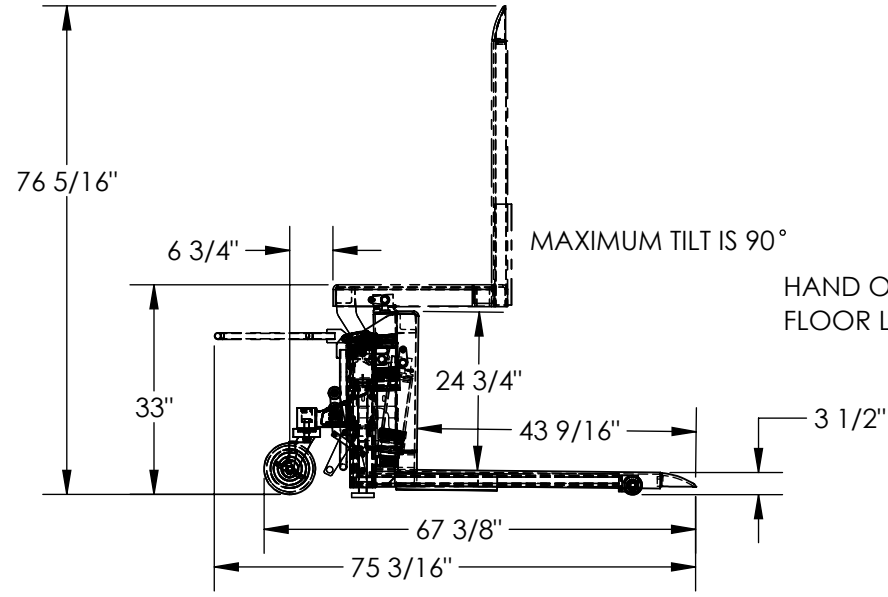

MAXIMUM TILT IS 90°

HAND OPERATED FLOOR LOCK

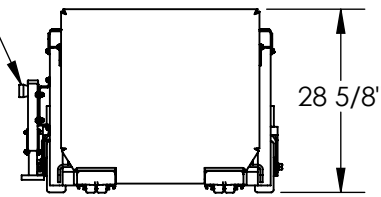

DIMENSION TOLERANCE ± 1/4"

STANDARD FEATURES

- MODEL NUMBER IS TM-60-AC
- CAPACITY IS 6,000 lbs
- OVERALL WIDTH IS 41 1/16"
- OVERALL LENGTH IS 75 1/4"
- OVERALL HEIGHT IS 76 5/16"
- ROTATED HEIGHT IS 33"
- LEVEL HEIGHT IS 28 5/8"
- FORK WIDTH IS 6 1/2" (WITH STIFFENER)
- USABLE FORK LENGTH IS 38 1/8"
- LOWERED FORK HEIGHT IS 3 1/2"
- FORK ADJUSTMENT FIXED AT 27" O.D.
- TILTING FORK OUTSIDE SPAN IS 26"
- INCLUDES HAND OPERATED FLOOR LOCK
- 115 VOLT AC POWERED
- DURABLE LIQUID PAINT BLUE FINISH

SPECIAL FEATURES

NONE

PLEASE CIRCLE SPECIFICATIONS:

| | | | |
|---------------------------------|--------|---------------------|-------------------------------|
| POWER | AC | DC (12V) | AIR/OIL |
| MOTOR VOLTAGE | 115 | 208 | 230 460 |
| DEDICATED CIRCUIT REQUIRED 60Hz | | | |
| MOTOR PHASE | SINGLE | THREE | |
| CONTROL | HAND | FOOT | |

APPROVAL

I, THE UNDERSIGNED, AGREE THAT THE PRODUCT AS REPRESENTED SATISFIES DESIGN AND DIMENSION REQUIREMENTS. I ALSO ACKNOWLEDGE MY DUTY TO CONFIRM PRODUCT AND INSTALLATION COMPLIANCE WITH ALL APPLICABLE FEDERAL, STATE AND LOCAL REGULATIONS AND STANDARDS.
UNITS REQUIRING APPROVAL DRAWINGS OR MODIFIED ARE NON-RETURNABLE
 As drawn As marked

Signed: _____ Date: _____

Printed Name: _____

LEAD TIME WILL START UPON RECEIPT OF SIGNED APPROVAL DRAWING

| | | |
|----------------------|--|-----------------------|
| DISTRIBUTOR'S NAME: | | P.O.# |
| VESTIL MANUFACTURING | | X |
| DRAWN BY: MWW | | DATE: 1/29/2013 |
| REFERENCE: X | | SCALE: 1:30 |
| QUOTED LEAD TIME: X | | QUOTE # X |
| | | SALES: X |
| | | FILE NAME: 38-007-024 |