

# TILT MASTER STRADDLE - TMS-20-AC

APPROX WEIGHT: 989 lbs.  
DOES NOT INCLUDE WEIGHT OF POWER OR PACKAGING!!!

\*\*\* ANY ADDITIONS, DELETIONS, OR OMISSIONS MUST BE CORRECTED ON THIS DRAWING AS THIS DRAWING WILL BE CONSIDERED ALL INCLUSIVE \*\*\*

ALL GRAPHICS PROVIDED ARE FOR REFERENCE ONLY. IF CERTAIN DIMENSIONS ARE CRITICAL PLEASE VERIFY THOSE DIMENSIONS WITH YOUR SALESPERSON

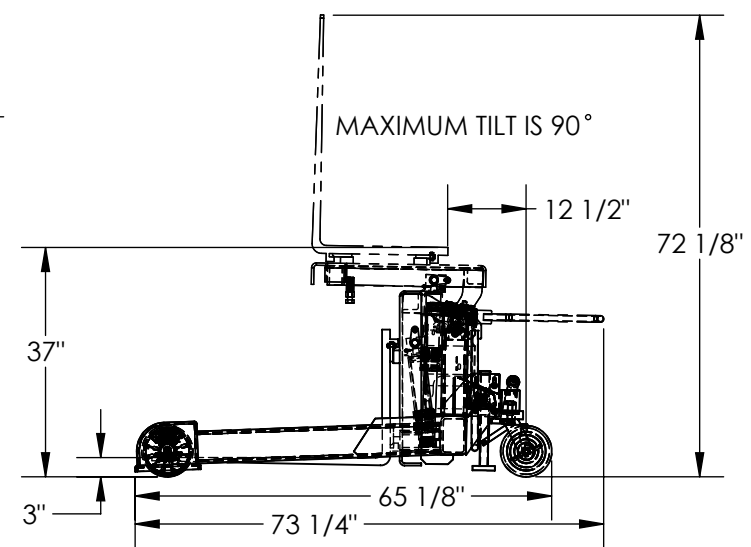
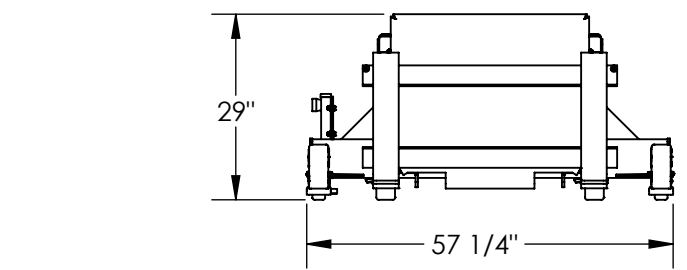
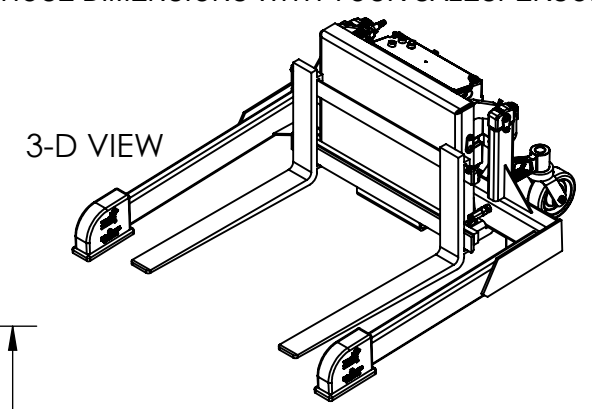
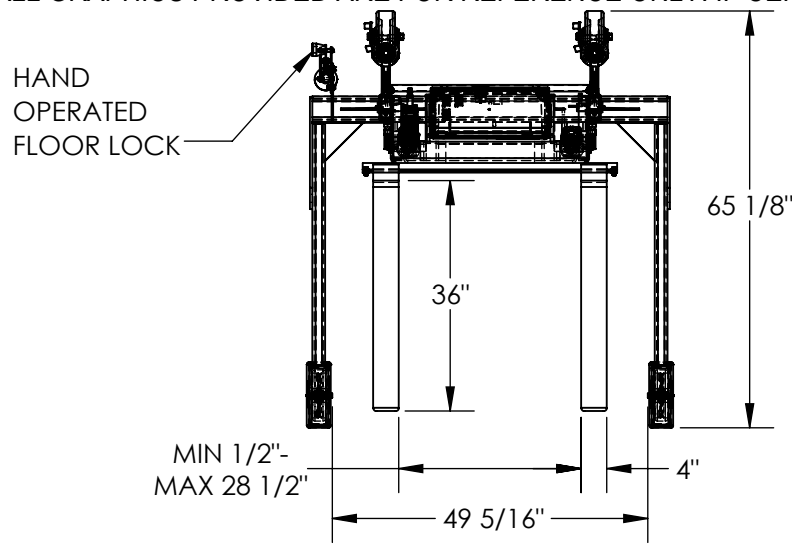

DIMENSION TOLERANCE ± 1/4"

## STANDARD FEATURES

- MODEL NUMBER IS TMS-20-AC
- CAPACITY IS 2,000 lbs
- FORK ADJUSTMENT IS 1/2" TO 28 1/2" I.D.
- OPERATOR REACH IS 12 1/2"
- STRADDLE I.D. IS 49 5/16"
- FORK WIDTH IS 4"
- USABLE FORK LENGTH IS 36"
- OVERALL WIDTH IS 57 1/4"
- OVERALL LENGTH IS 73 1/4"
- OVERALL HEIGHT IS 72 1/8"
- LOWERED FORK HEIGHT IS 3"
- ROTATED HEIGHT IS 37"
- LEVEL HEIGHT IS 29"
- INCLUDES HAND OPERATED FLOOR LOCK
- 115 VOLT AC POWERED
- DURABLE LIQUID PAINT BLUE FINISH

## SPECIAL FEATURES

NONE

## PLEASE CIRCLE SPECIFICATIONS:

POWER	AC	DC (12V)	AIR/OIL
MOTOR VOLTAGE	115	208	230 460
DEDICATED CIRCUIT REQUIRED 60Hz			
MOTOR PHASE	SINGLE	THREE	
CONTROL	HAND	FOOT	

**APPROVAL**

I, THE UNDERSIGNED, AGREE THAT THE PRODUCT AS REPRESENTED SATISFIES DESIGN AND DIMENSION REQUIREMENTS. I ALSO ACKNOWLEDGE MY DUTY TO CONFIRM PRODUCT AND INSTALLATION COMPLIANCE WITH ALL APPLICABLE FEDERAL, STATE AND LOCAL REGULATIONS AND STANDARDS.

**UNITS REQUIRING APPROVAL DRAWINGS OR MODIFIED ARE NON-RETURNABLE**

[ ] As drawn [ ] As marked

Signed: \_\_\_\_\_ Date: \_\_\_\_\_

Printed Name: \_\_\_\_\_

LEAD TIME WILL START UPON RECEIPT OF SIGNED APPROVAL DRAWING

DISTRIBUTOR'S NAME:		P.O.#
VESTIL MANUFACTURING		X
DRAWN BY: MWW		W.O.#
DATE: 1/30/2013		X
REFERENCE: X	SCALE: 1:30	SALES: X
QUOTED LEAD TIME: X	QUOTE # X	FILE NAME:
		38-007-029