

# TILT MASTER STRADDLE - TMS-20-DC-PTDS

APPROX WEIGHT: 989 lbs.  
DOES NOT INCLUDE WEIGHT OF POWER OR PACKAGING!!!

\*\*\* ANY ADDITIONS, DELETIONS, OR OMISSIONS MUST BE CORRECTED ON THIS DRAWING AS THIS DRAWING WILL BE CONSIDERED ALL INCLUSIVE \*\*\*

ALL GRAPHICS PROVIDED ARE FOR REFERENCE ONLY. IF CERTAIN DIMENSIONS ARE CRITICAL PLEASE VERIFY THOSE DIMENSIONS WITH YOUR SALESPERSON

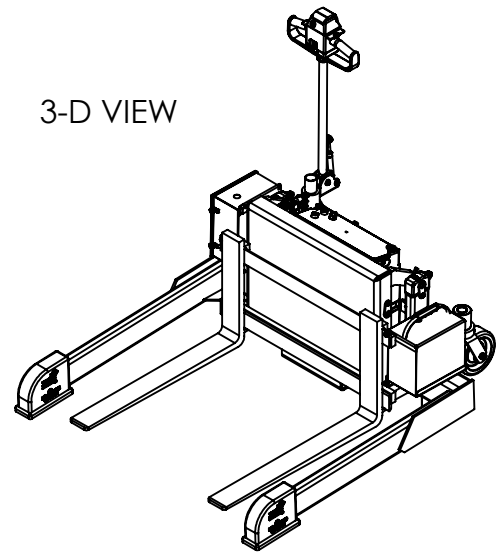
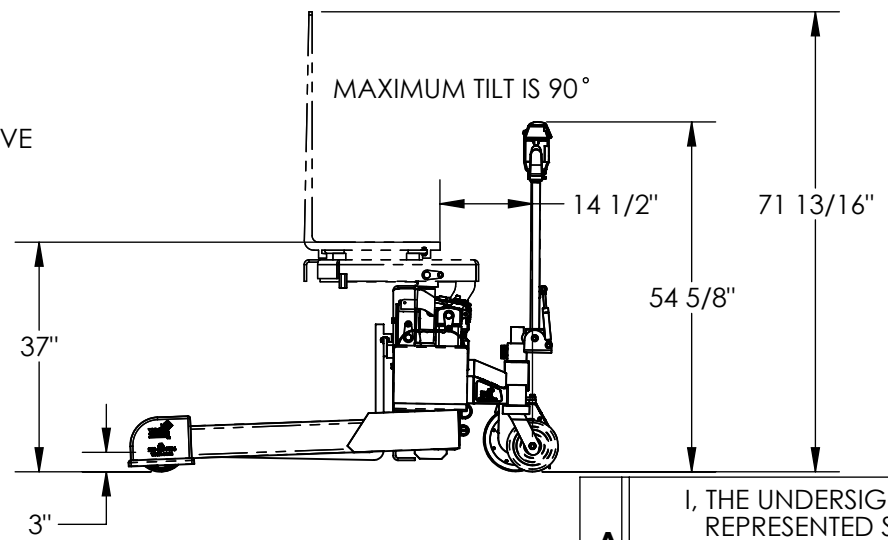
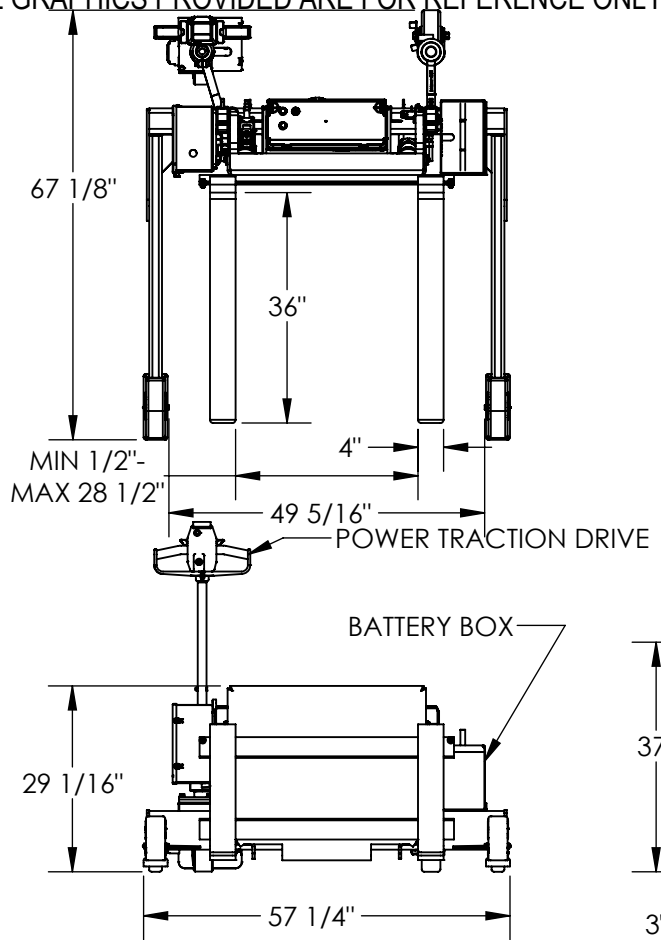

3-D VIEW

DIMENSION TOLERANCE ± 1/4"

**STANDARD FEATURES**  
 MODEL NUMBER IS TMS-20-DC-PTDS  
 CAPACITY IS 2,000 LBS  
 FORK ADJUSTMENT IS 1/2" TO 28 1/2" I.D.  
 STRADDLE I.D. IS 49 5/16"  
 FORK WIDTH IS 4"  
 USABLE FORK LENGTH IS 36"  
 OVERALL WIDTH IS 57 1/4"  
 OVERALL LENGTH IS 67 1/8"  
 OVERALL HEIGHT IS 54 5/8"  
 LOWERED FORK HEIGHT IS 3"  
 ROTATED HEIGHT IS 71 13/16"  
 LEVEL HEIGHT IS 37"  
 MAXIMUM TILT IS 90°  
 DC POWERED  
 DURABLE LIQUID PAINT BLUE FINISH

**POWER TRACTION DRIVE**  
 24V DC POWER  
 VARIABLE SPEED DRIVE  
 SOFT START AND STOP  
 EMERGENCY BELLY SWITCH  
 ELECTROMAGNETIC PARKING  
 BRAKE/EMERGENCY BRAKE  
 KEYED IGNITION  
 ON BOARD BATTERY CHARGER  
 BUTTERFLY STYLE THROTTLE TRIGGER  
 PROGRAMMABLE DC CONTROL CARD  
 FOR CUSTOM PREFERENCES

**APPROVAL**

I, THE UNDERSIGNED, AGREE THAT THE PRODUCT AS REPRESENTED SATISFIES DESIGN AND DIMENSION REQUIREMENTS. I ALSO ACKNOWLEDGE MY DUTY TO CONFIRM PRODUCT AND INSTALLATION COMPLIANCE WITH ALL APPLICABLE FEDERAL, STATE AND LOCAL REGULATIONS AND STANDARDS.  
**UNITS REQUIRING APPROVAL DRAWINGS OR MODIFIED ARE NON-RETURNABLE**  
 As drawn       As marked

Signed: \_\_\_\_\_ Date: \_\_\_\_\_  
 Printed Name: \_\_\_\_\_

*LEAD TIME WILL START UPON RECEIPT OF SIGNED APPROVAL DRAWING*

DISTRIBUTOR'S NAME:		P.O.#
VESTIL MANUFACTURING		X
DRAWN BY: KGH		W.O.#
DATE: 6/5/2020		X
REFERENCE: X	SCALE: 1:30	SALES: X
QUOTED LEAD TIME: X	QUOTE # X	FILE NAME:
		15-007-159