

TILT MASTER STRADDLE - TMS-40-DC-PTDS

APPROX WEIGHT: 989 lbs.
DOES NOT INCLUDE WEIGHT OF POWER OR PACKAGING!!!

*** ANY ADDITIONS, DELETIONS, OR OMISSIONS MUST BE CORRECTED ON THIS DRAWING AS THIS DRAWING WILL BE CONSIDERED ALL INCLUSIVE ***

ALL GRAPHICS PROVIDED ARE FOR REFERENCE ONLY. IF CERTAIN DIMENSIONS ARE CRITICAL PLEASE VERIFY THOSE DIMENSIONS WITH YOUR SALESPERSON

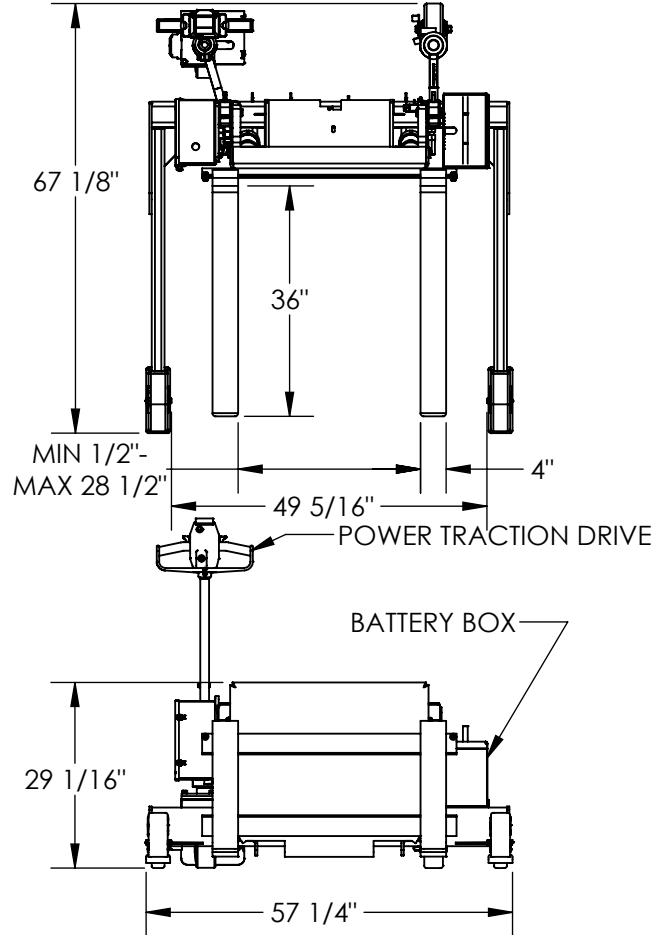

3-D VIEW

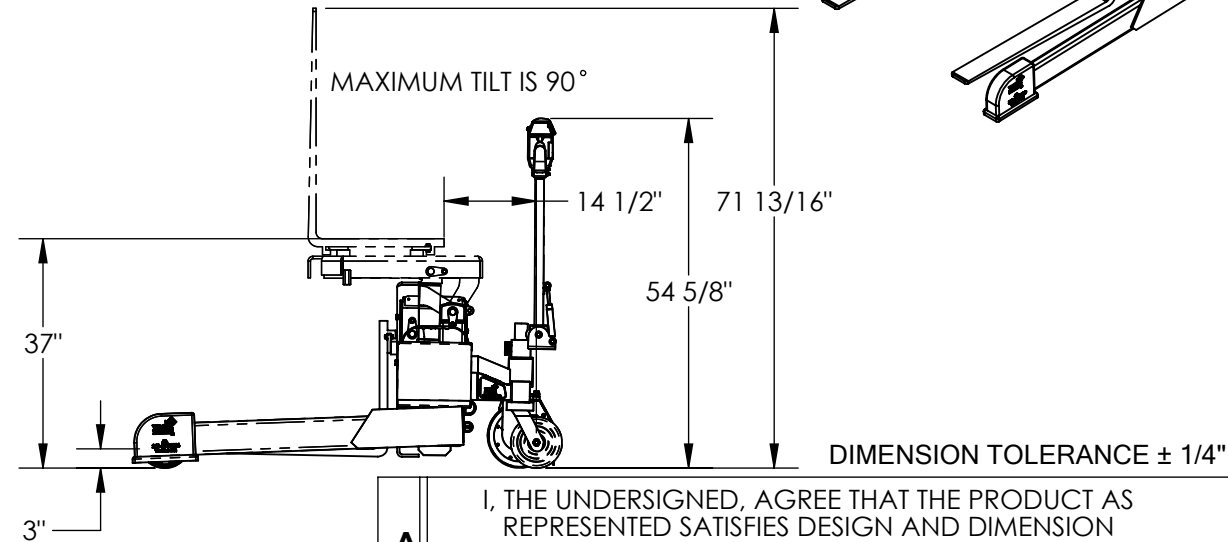
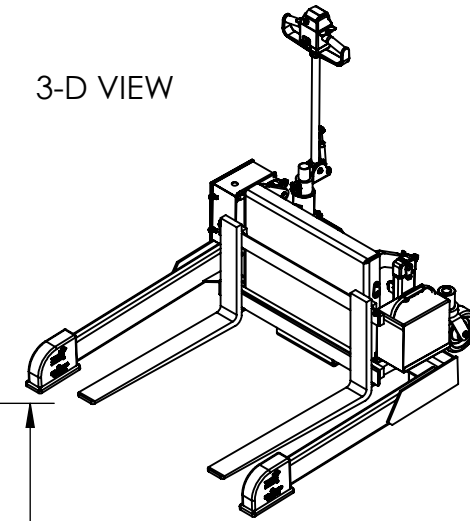

STANDARD FEATURES

MODEL NUMBER IS TMS-40-DC-PTDS
CAPACITY IS 4,000 LBS
FORK ADJUSTMENT IS 1/2" TO 28 1/2" I.D.
STRADDLE I.D. IS 49 5/16"
FORK WIDTH IS 4"
USABLE FORK LENGTH IS 36"
OVERALL WIDTH IS 57 1/4"
OVERALL LENGTH IS 67 1/8"
OVERALL HEIGHT IS 54 5/8"
LOWERED FORK HEIGHT IS 3"
ROTATED HEIGHT IS 71 13/16"
LEVEL HEIGHT IS 37"
MAXIMUM TILT IS 90°
DC POWERED
DURABLE LIQUID PAINT BLUE FINISH

POWER TRACTION DRIVE

24V DC POWER
VARIABLE SPEED DRIVE
SOFT START AND STOP
EMERGENCY BELLY SWITCH
ELECTROMAGNETIC PARKING
BRAKE/EMERGENCY BRAKE
KEYED IGNITION
ON BOARD BATTERY CHARGER
BUTTERFLY STYLE THROTTLE TRIGGER
PROGRAMMABLE DC CONTROL CARD
FOR CUSTOM PREFERENCES

I, THE UNDERSIGNED, AGREE THAT THE PRODUCT AS REPRESENTED SATISFIES DESIGN AND DIMENSION REQUIREMENTS. I ALSO ACKNOWLEDGE MY DUTY TO CONFIRM PRODUCT AND INSTALLATION COMPLIANCE WITH ALL APPLICABLE FEDERAL, STATE AND LOCAL REGULATIONS AND STANDARDS.
UNITS REQUIRING APPROVAL DRAWINGS OR MODIFIED ARE NON-RETURNABLE

[] As drawn [] As marked

Signed: _____ Date: _____

Printed Name: _____

LEAD TIME WILL START UPON RECEIPT OF SIGNED APPROVAL DRAWING

DISTRIBUTOR'S NAME:		P.O.#
VESTIL MANUFACTURING		X
DRAWN BY: KGH		W.O.#
DATE: 6/9/2020		X
REFERENCE: X	SCALE: 1:30	SALES: X
QUOTED LEAD TIME: X	QUOTE #	FILE NAME:
	X	15-007-160