

TILT MASTER STRADDLE - TMS-60-AC

APPROX WEIGHT: 978lbs.
DOES NOT INCLUDE WEIGHT OF POWER OR PACKAGING!!!

*** ANY ADDITIONS, DELETIONS, OR OMISSIONS MUST BE CORRECTED ON THIS DRAWING AS THIS DRAWING WILL BE CONSIDERED ALL INCLUSIVE ***

ALL GRAPHICS PROVIDED ARE FOR REFERENCE ONLY. IF CERTAIN DIMENSIONS ARE CRITICAL PLEASE VERIFY THOSE DIMENSIONS WITH YOUR SALESPERSON

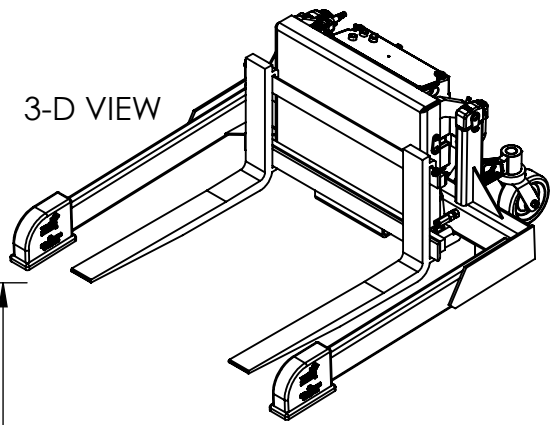
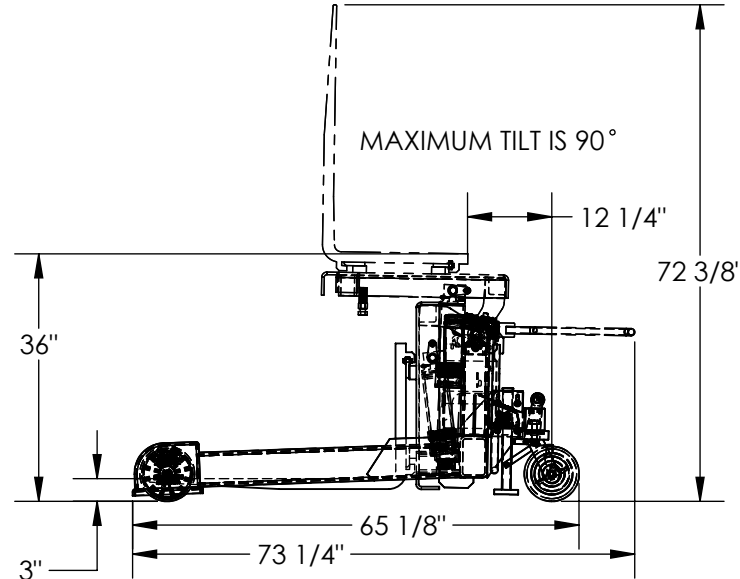
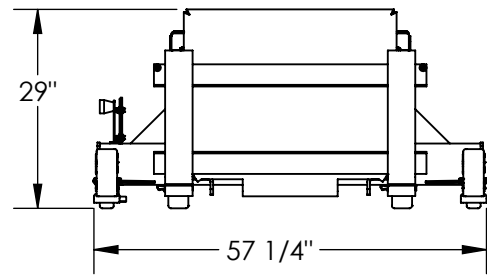
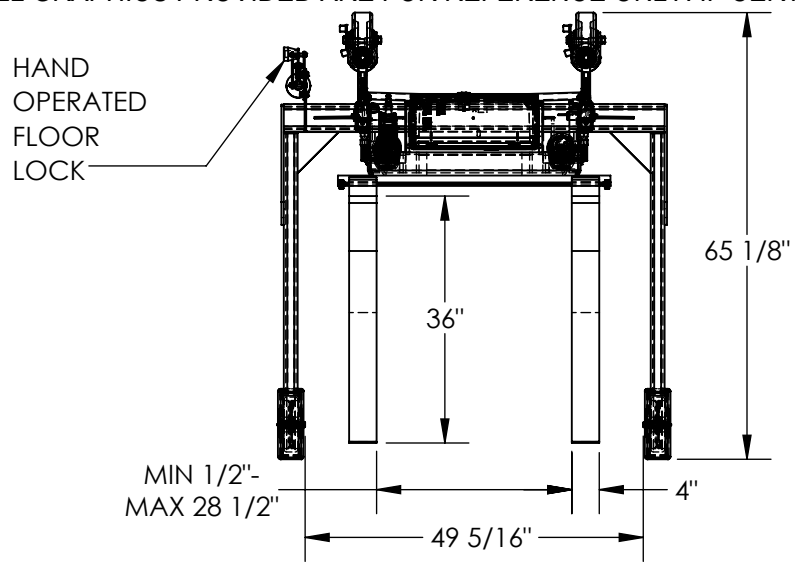

DIMENSION TOLERANCE ± 1/4"

STANDARD FEATURES

- MODEL NUMBER IS TMS-60-AC
- CAPACITY IS 6,000 lbs
- FORK ADJUSTMENT IS 1/2" TO 28 1/2" I.D.
- OPERATOR REACH IS 12 1/4"
- STRADDLE I.D. IS 49 5/16"
- FORK WIDTH IS 4"
- USABLE FORK LENGTH IS 36"
- OVERALL WIDTH IS 57 1/4"
- OVERALL LENGTH IS 73 1/4"
- OVERALL HEIGHT IS 72 3/8"
- LOWERED FORK HEIGHT IS 3"
- ROTATED HEIGHT IS 36"
- LEVEL HEIGHT IS 29"
- INCLUDES HAND OPERATED FLOOR LOCK
- 115 VOLT AC POWERED
- DURABLE LIQUID PAINT BLUE FINISH

SPECIAL FEATURES

NONE

PLEASE CIRCLE SPECIFICATIONS:

POWER	AC	DC (12V)	AIR/OIL
MOTOR VOLTAGE	115	208	230 460
DEDICATED CIRCUIT REQUIRED 60Hz			
MOTOR PHASE	SINGLE	THREE	
CONTROL	HAND	FOOT	

APPROVAL

I, THE UNDERSIGNED, AGREE THAT THE PRODUCT AS REPRESENTED SATISFIES DESIGN AND DIMENSION REQUIREMENTS. I ALSO ACKNOWLEDGE MY DUTY TO CONFIRM PRODUCT AND INSTALLATION COMPLIANCE WITH ALL APPLICABLE FEDERAL, STATE AND LOCAL REGULATIONS AND STANDARDS.

UNITS REQUIRING APPROVAL DRAWINGS OR MODIFIED ARE NON-RETURNABLE

[] As drawn [] As marked

Signed: _____ Date: _____

Printed Name: _____

LEAD TIME WILL START UPON RECEIPT OF SIGNED APPROVAL DRAWING

DISTRIBUTOR'S NAME:		P.O.#
VESTIL MANUFACTURING		X
DRAWN BY: MWW		DATE: 1/29/2013
REFERENCE: X		SCALE: 1:28
QUOTED LEAD TIME: X		QUOTE # X
		SALES: X
		FILE NAME: 38-007-027