

TRUCK CRANE - WTJ-HITCH

APPROX WEIGHT: 134.33 lbs.
DOES NOT INCLUDE WEIGHT OF POWER OR PACKAGING!!!

*** ANY ADDITIONS, DELETIONS, OR OMISSIONS MUST BE CORRECTED ON THIS DRAWING AS THIS DRAWING WILL BE CONSIDERED ALL INCLUSIVE ***
ALL GRAPHICS PROVIDED ARE FOR REFERENCE ONLY. IF CERTAIN DIMENSIONS ARE CRITICAL PLEASE VERIFY THOSE DIMENSIONS WITH YOUR SALESPERSON

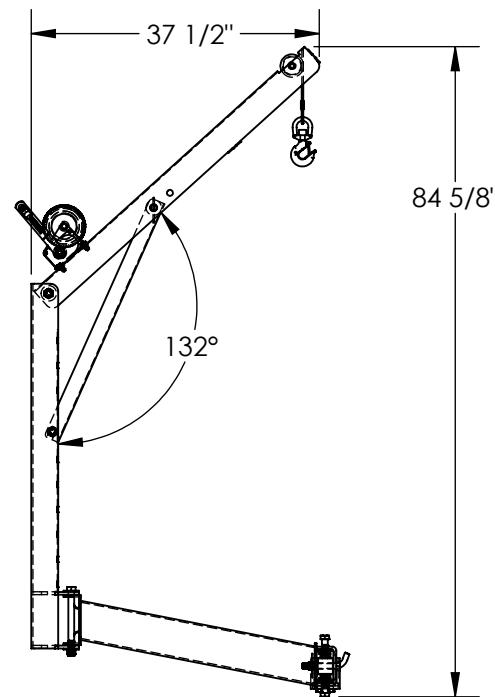
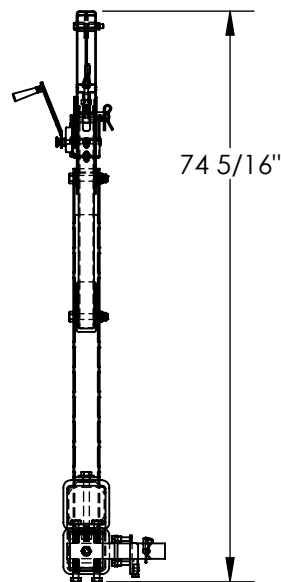
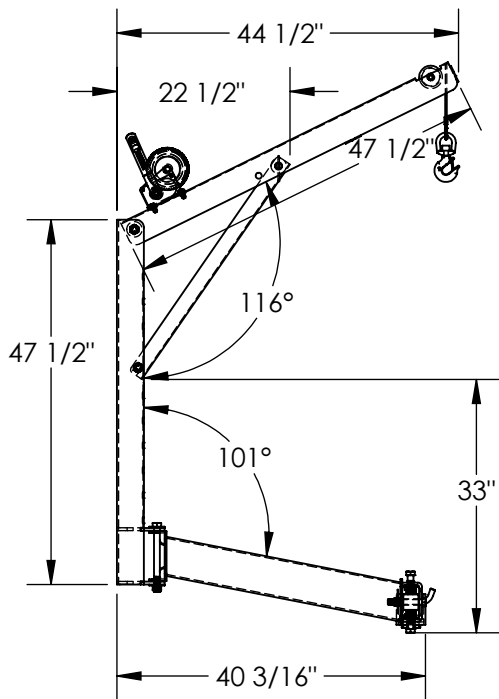

EXTENDED CLEARANCE POSITION

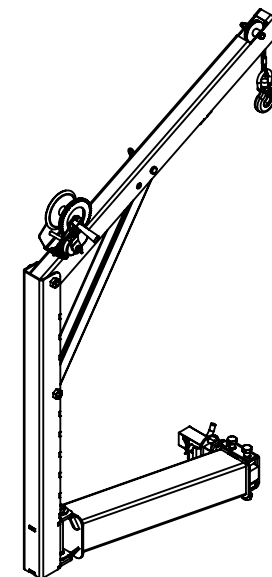

DIMENSION TOLERANCE ± 1/4"

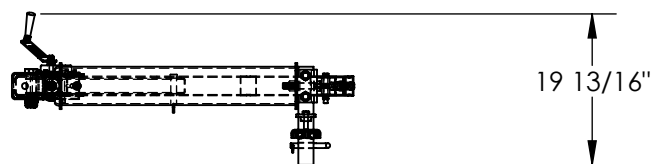

STANDARD FEATURES

- MODEL NUMBER IS WTJ-HITCH
- CAPACITY IS 600 LBS
- OVERALL WIDTH IS 19 13/16"
- OVERALL LENGTH IS 44 1/2"
- OVERALL HEIGHT IS 74 5/16"
- MAXIMUM HEIGHT IS 84 5/8"
- EASILY MOUNTS IN STANDARD CLASS III OR HIGHER 2" RECEIVER
- INSTALLATION & USE REQUIRES NO MODIFICATIONS TO TRUCK
- UNIT MAY BE ADJUSTED/LEVELED FOR BEST USE
- MANUAL HAND BRAKE WINCH AND LIFTING HOOK
- EXTENDED CABLE LENGTH IS 15 FT
- CRANE MAY BE INSTALLED ON EITHER SIDE OF TRUCK
- RUGGED WELDED STEEL CONSTRUCTION
- TOUGH BAKED IN POWDER-COATED BLACK FINISH

SPECIAL FEATURES

NONE

APPROVAL

I, THE UNDERSIGNED, AGREE THAT THE PRODUCT AS REPRESENTED SATISFIES DESIGN AND DIMENSION REQUIREMENTS. I ALSO ACKNOWLEDGE MY DUTY TO CONFIRM PRODUCT AND INSTALLATION COMPLIANCE WITH ALL APPLICABLE FEDERAL, STATE AND LOCAL REGULATIONS AND STANDARDS.
UNITS REQUIRING APPROVAL DRAWINGS OR MODIFIED ARE NON-RETURNABLE
[] As drawn [] As marked

Signed: _____ Date: _____

Printed Name: _____

LEAD TIME WILL START UPON RECEIPT OF SIGNED APPROVAL DRAWING

DISTRIBUTOR'S NAME:		P.O.#
VESTIL MANUFACTURING		X
DRAWN BY: BCN	DATE: 2/5/2016	W.O.#
REFERENCE: X	SCALE: 1:25	X
QUOTED LEAD TIME: X	QUOTE #	SALES: X
	X	FILE NAME:
		28-007-348