

# STAINLESS STEEL HYD FOOT PUMP ROLL HANDLER - ULM-HRH-850

APPROX WEIGHT: 113.5 lbs.  
 DOES NOT INCLUDE WEIGHT OF POWER OR PACKAGING!!!

\*\*\* ANY ADDITIONS, DELETIONS, OR OMISSIONS MUST BE CORRECTED ON THIS DRAWING AS THIS DRAWING WILL BE CONSIDERED ALL INCLUSIVE \*\*\*

ALL GRAPHICS PROVIDED ARE FOR REFERENCE ONLY. IF CERTAIN DIMENSIONS ARE CRITICAL PLEASE VERIFY THOSE DIMENSIONS WITH YOUR SALESPERSON

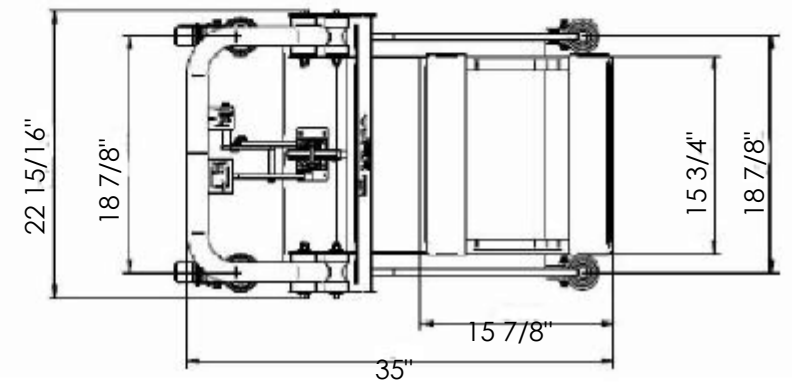
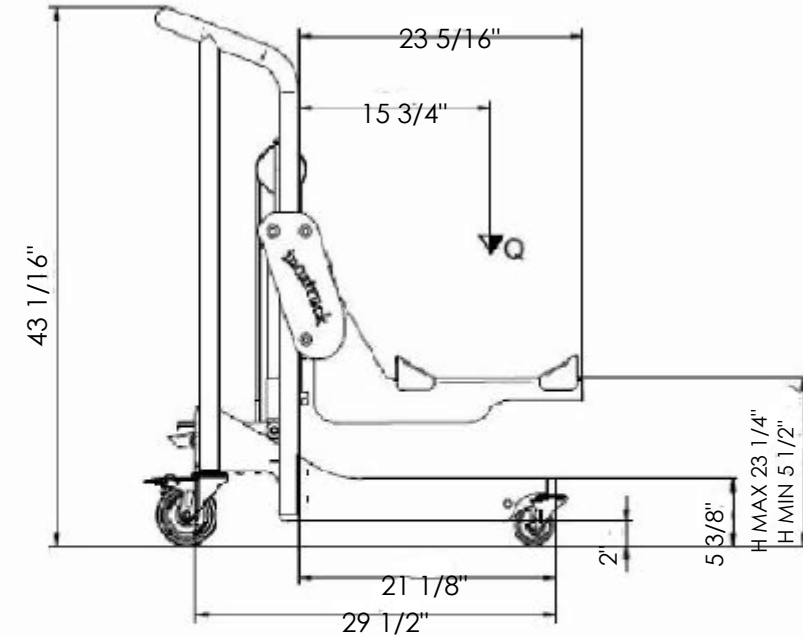
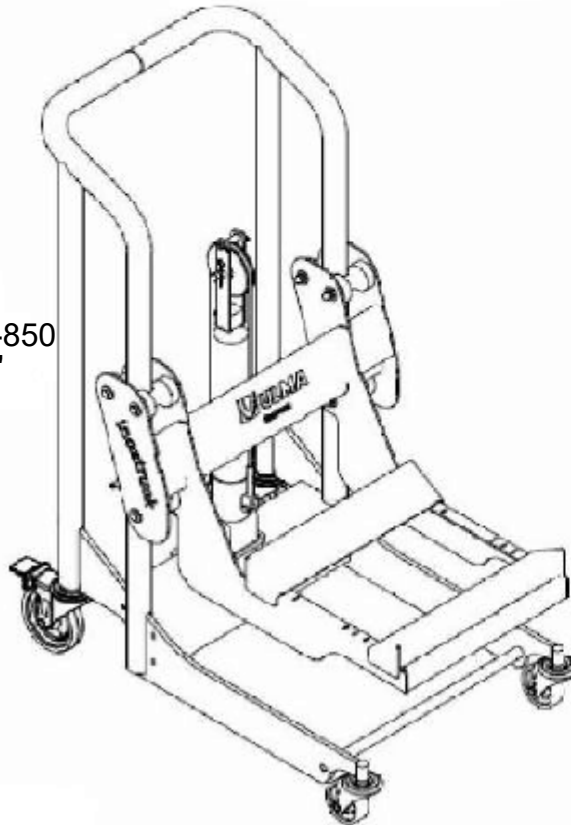

DIMENSION TOLERANCE ± 1/2"

**STANDARD FEATURES**  
 MODEL NUMBER IS ULM-HR-850  
 OVERALL WIDTH IS 22 15/16"  
 OVERALL LENGTH IS 35"  
 OVERALL HEIGHT IS 43 1/16"  
 MAX CAPACITY IS 850 LBS

**SPECIAL FEATURES**  
 NONE

APPROVAL

I, THE UNDERSIGNED, AGREE THAT THE PRODUCT AS REPRESENTED SATISFIES DESIGN AND DIMENSION REQUIREMENTS. I ALSO ACKNOWLEDGE MY DUTY TO CONFIRM PRODUCT AND INSTALLATION COMPLIANCE WITH ALL APPLICABLE FEDERAL, STATE AND LOCAL REGULATIONS AND STANDARDS.

**UNITS REQUIRING APPROVAL DRAWINGS OR MODIFIED ARE NON-RETURNABLE**

As drawn       As marked

Signed: \_\_\_\_\_ Date: \_\_\_\_\_

Printed Name: \_\_\_\_\_

LEAD TIME WILL START UPON RECEIPT OF SIGNED APPROVAL DRAWING

FOR INTERNAL USE ONLY  
 PROJECT SIGN OFF

SALES	
ENG.	
FAB.	
POWER	

DISTRIBUTOR'S NAME: <b>VESTIL MANUFACTURING</b>		P.O.# X
DRAWN BY: TAW		W.O.# X
DATE: 5/2/2017	SALES: X	
REFERENCE: X	SCALE: NTS	FILE NAME:
QUOTED LEAD TIME: X	QUOTE # X	ULM-HRH-850