

# STAINLESS STEEL POWERED TILT MASTER - ULM-TM-15-2331

APPROX WEIGHT: 369 lbs. DOES NOT INCLUDE WEIGHT OF POWER OR PACKAGING!!!

\*\*\* ANY ADDITIONS, DELETIONS, OR OMISSIONS MUST BE CORRECTED ON THIS DRAWING AS THIS DRAWING WILL BE CONSIDERED ALL INCLUSIVE \*\*\*

ALL GRAPHICS PROVIDED ARE FOR REFERENCE ONLY. IF CERTAIN DIMENSIONS ARE CRITICAL PLEASE VERIFY THOSE DIMENSIONS WITH YOUR SALESPERSON

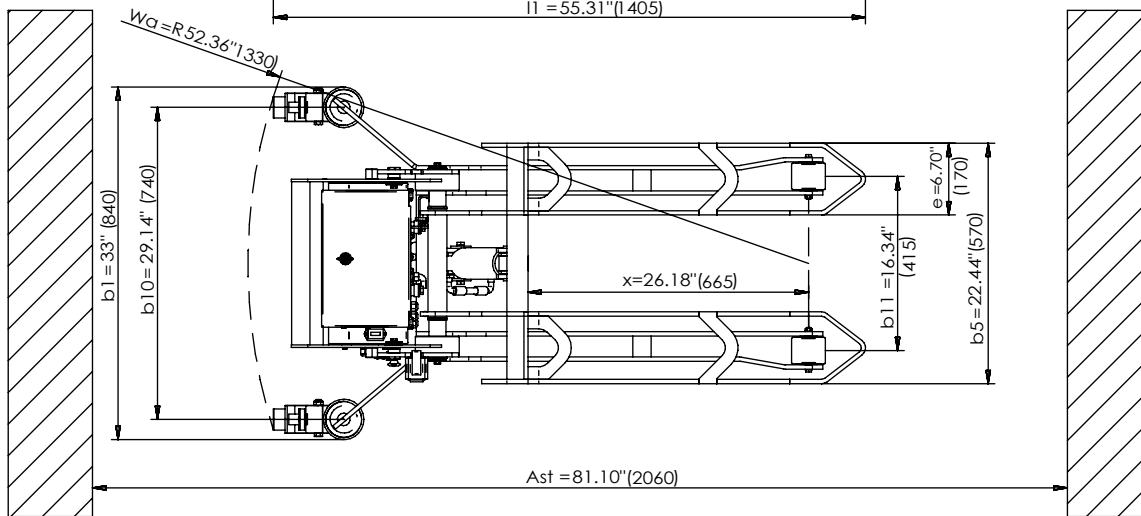
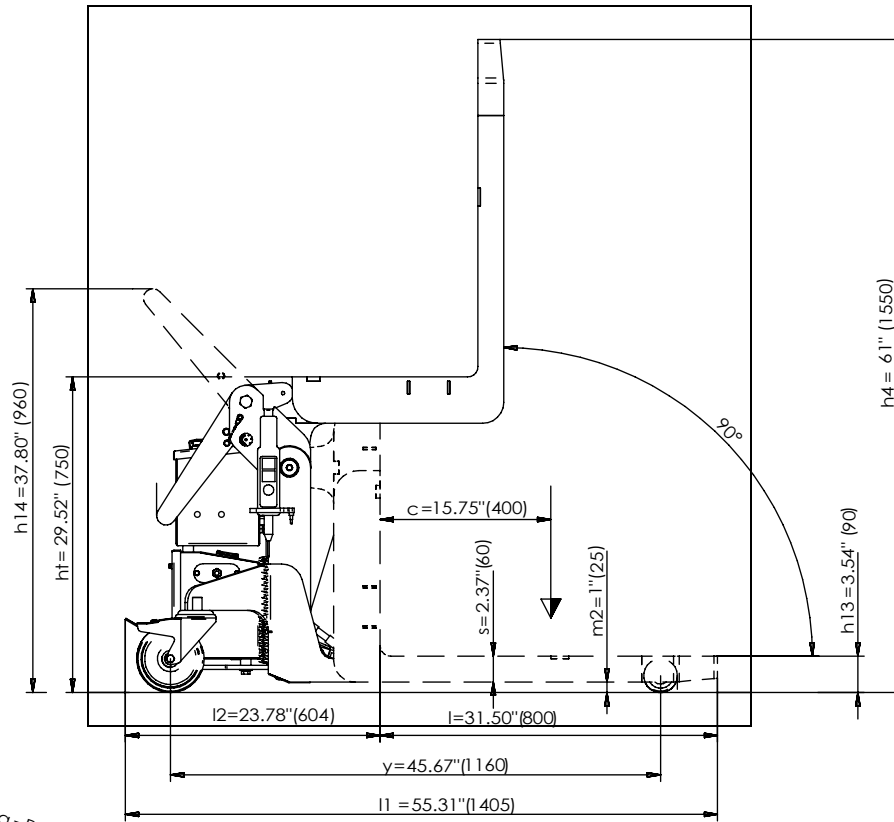

## SPECIFICATIONS:

- MODEL NO: ULM-TM-15-2331
- CAPACITY: 1,500 LBS (680 kgs)
- OVERALL LENGTH: 55 5/16"
- OVERALL WIDTH: 33 1/16"
- LOWERED FORK HEIGHT: 3 9/16"
- LEVEL HEIGHT: 29 1/2"
- MAXIMUM TILT ANGLE: 90°
- RAISED HEIGHT: 61"
- FORK SIZE: 6 11/16"W X 31 1/2"L
- LIFT MOTOR: 12V / 2.0 Kw
- BATTERY: (1) 12 / 52 Ah
- TILTING TIME W/ LOAD: 17 sec
- TILTING TIME W/O LOAD: 14 sec
- LOWERING SPEED W/ LOAD: 11 sec
- LOWERING SPEED W/O LOAD: 17 sec
- STAINLESS STEEL CONSTRUCTION

DIMENSION TOLERANCE ± 1/2"

APPROVAL

I, THE UNDERSIGNED, AGREE THAT THE PRODUCT AS REPRESENTED SATISFIES DESIGN AND DIMENSION REQUIREMENTS. I ALSO ACKNOWLEDGE MY DUTY TO CONFIRM PRODUCT AND INSTALLATION COMPLIANCE WITH ALL APPLICABLE FEDERAL, STATE AND LOCAL REGULATIONS AND STANDARDS.

**UNITS REQUIRING APPROVAL DRAWINGS OR MODIFIED ARE NON-RETURNABLE**

[ ] As drawn [ ] As marked

Signed: \_\_\_\_\_ Date: \_\_\_\_\_

Printed Name: \_\_\_\_\_

LEAD TIME WILL START UPON RECEIPT OF SIGNED APPROVAL DRAWING

DISTRIBUTOR'S NAME:		P.O.#
VESTIL MANUFACTURING		X
DRAWN BY: TM	DATE: 6/12/2020	W.O.#
REFERENCE: X	SCALE: NTS	X
QUOTED LEAD TIME: X	QUOTE #	FILE NAME:
	X	ULM-TM-15-2331