

# SINGLE SCISSOR LIFT & TILT TABLE - UNI-5448-6

APPROX WEIGHT: 897.19 lbs.  
DOES NOT INCLUDE WEIGHT OF POWER OR PACKAGING!!!

\*\*\* ANY ADDITIONS, DELETIONS, OR OMISSIONS MUST BE CORRECTED ON THIS DRAWING AS THIS DRAWING WILL BE CONSIDERED ALL INCLUSIVE \*\*\*

ALL GRAPHICS PROVIDED ARE FOR REFERENCE ONLY. IF CERTAIN DIMENSIONS ARE CRITICAL PLEASE VERIFY THOSE DIMENSIONS WITH YOUR SALESPERSON

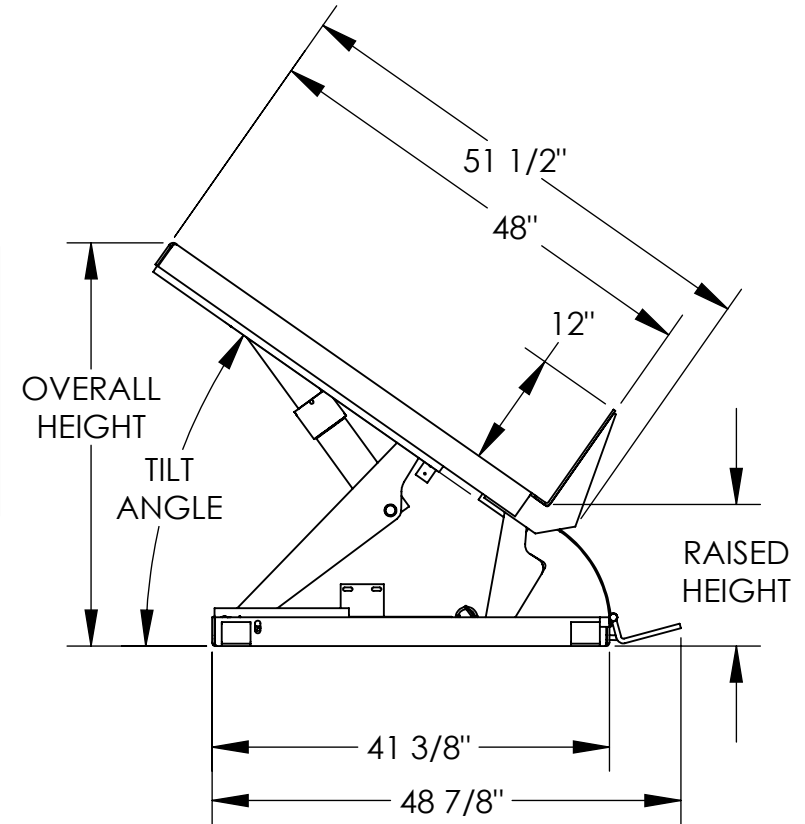
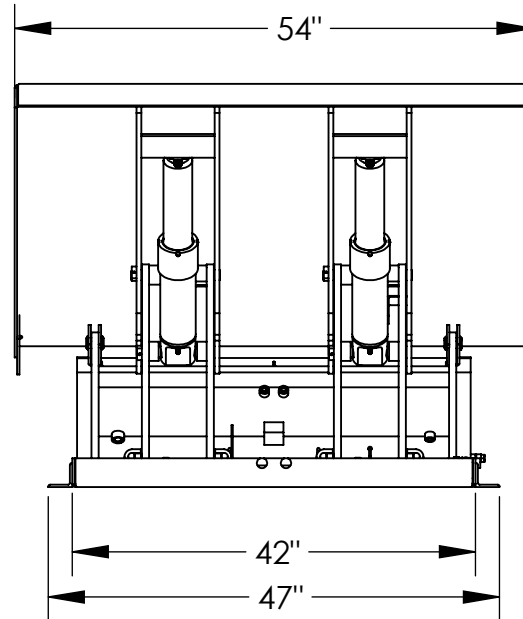
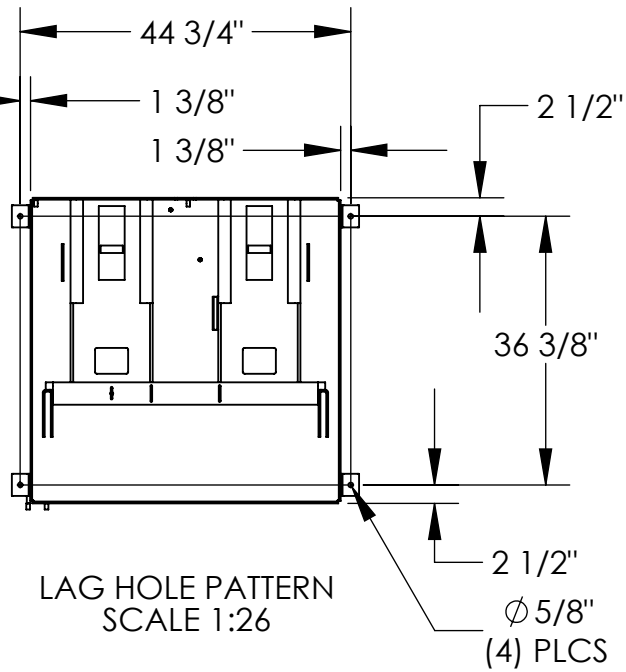

DIMENSION TOLERANCE ± 1/4"

## STANDARD FEATURES

MODEL NUMBER IS: UNI-5448-6  
CAPACITY: 6,000 LBS. EVENLY DISTRIBUTED  
SEQUENCE 1:

RAISED HEIGHT: 14 3/4", TILT ANGLE 35°  
OVERALL HEIGHT: 42"

SEQUENCE 2:

RAISED HEIGHT 11 3/4", TILT ANGLE: 40°  
OVERALL HEIGHT 42 1/4"

LEVEL HEIGHT: 8"

DECK SIZE: 54" W X 48" L WITH 12" LIP  
INTEGRAL MAINTENANCE LOCK  
ADJUSTABLE UPWARD TRAVEL LIMIT SWITCH  
UNIT MUST BE LAGGED TO THE FLOOR  
DURABLE LIQUID PAINT BLUE FINISH

## SPECIAL FEATURES

NONE

### PLEASE CIRCLE SPECIFICATIONS:

POWER	AC	* DC	* AIR/OIL
MOTOR VOLTAGE	115	208	230 460
DEDICATED CIRCUIT REQUIRED			
MOTOR PHASE	SINGLE	THREE	
CONTROL	HAND	* FOOT	
~ ALL BATTERY CHARGERS ARE 115V AC ~			
* BATTERY CHRG.	REMOTE	ON-BOARD	
* CHRG. INDICATOR	YES	NO	

\* AVAILABLE AT ADDITIONAL COST

**A P P R O V A L**

I, THE UNDERSIGNED, AGREE THAT THE PRODUCT AS REPRESENTED SATISFIES DESIGN AND DIMENSION REQUIREMENTS. I ALSO ACKNOWLEDGE MY DUTY TO CONFIRM PRODUCT AND INSTALLATION COMPLIANCE WITH ALL APPLICABLE FEDERAL, STATE AND LOCAL REGULATIONS AND STANDARDS.  
**UNITS REQUIRING APPROVAL DRAWINGS OR MODIFIED ARE NON-RETURNABLE**  
[ ] As drawn [ ] As marked

Signed: \_\_\_\_\_ Date: \_\_\_\_\_

Printed Name: \_\_\_\_\_

LEAD TIME WILL START UPON RECEIPT OF SIGNED APPROVAL DRAWING

DISTRIBUTOR'S NAME: VESTIL MANUFACTURING

P.O.# X

W.O.# X

SALES: X

FILE NAME: 03-007-045

DRAWN BY: MTS DATE: XX/XX/XX

REFERENCE: X SCALE: 1:20

QUOTED LEAD TIME: X QUOTE # X