

NESTABLE WIRE CART - WIRE-M

ANY ADDITIONS, DELETIONS, OR OMISSIONS MUST BE CORRECTED ON THIS DRAWING AS THIS DRAWING WILL BE CONSIDERED ALL INCLUSIVE
 ALL GRAPHICS PROVIDED ARE FOR REFERENCE ONLY. IF CERTAIN DIMENSIONS ARE CRITICAL PLEASE VERIFY THOSE DIMENSIONS WITH YOUR SALESPERSON

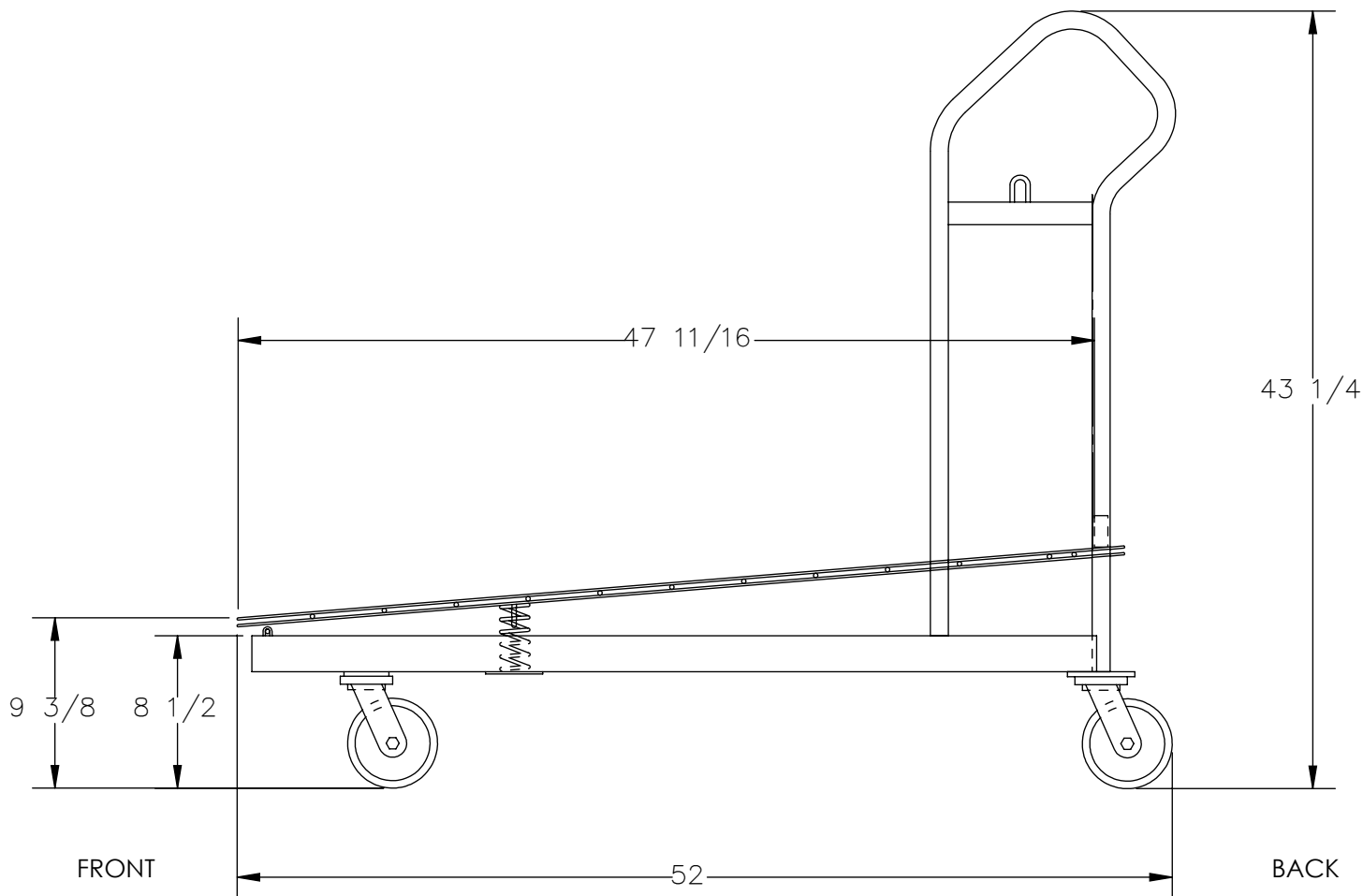

FOR INTERNAL USE ONLY	
PROJECT SIGN OFF	
SALES	
ENG.	
FAB.	
POWER	

DIMENSION TOLERANCE $\pm 1/2"$

STANDARD FEATURES

- MODEL NUMBER IS: WIRE-M
- MAX CAPACITY IS: 90 LBS
- FRONT USABLE WIDTH IS: 22"
- BACK USABLE WIDTH IS: 27"
- OVERALL LENGTH IS: 52"
- OVERALL HEIGHT IS: 43 1/4"
- USABLE PLATFORM LENGTH IS: 47 11/16"
- (4) 1 1/4" x 4 3/4" SWIVEL CASTERS

SPECIAL FEATURES

NONE

A P P R O V A L	I, THE UNDERSIGNED, AGREE THAT THE PRODUCT AS REPRESENTED SATISFIES DESIGN AND DIMENSION REQUIREMENTS. I ALSO ACKNOWLEDGE MY DUTY TO CONFIRM PRODUCT AND INSTALLATION COMPLIANCE WITH ALL APPLICABLE FEDERAL, STATE AND LOCAL REGULATIONS AND STANDARDS.	
	UNITS REQUIRING APPROVAL DRAWINGS OR MODIFIED ARE NON-RETURNABLE	
	[] As drawn [] As marked	
	Signed: _____	Date: _____
Printed Name: _____		
<i>LEAD TIME WILL START UPON RECEIPT OF SIGNED APPROVAL DRAWING</i>		

DISTRIBUTOR'S NAME:		P.O.#
VESTIL MANUFACTURING		X
		W.O.#
DRAWN BY: JGP		X
DATE: 10/16/2020		SALES: X
REFERENCE: X	SCALE: NTS	FILE NAME:
QUOTED LEAD TIME: X	QUOTE # X	WIRE-M