

CHESTER
HOIST

ZEPHYR™

MANUAL HOISTS & TROLLEYS

- HOOK SUSPENDED
- CLEVIS CONNECTED
- ARMY TYPE
- LOW HEADROOM
- SWIVEL TRUCK
- LOW HEADROOM
- TWIN HOOK
- EXTENDED HANDWHEEL
- TROLLEYS



COLUMBUS MCKINNON CORPORATION



ZEPHYR™

MANUAL HOISTS & TROLLEYS

CHESTER ZEPHYR hoists are designed, built and tested to the highest quality and performance standards, meeting or exceeding the rigid specifications of the material handling industry.

The Chester Zephyr is engineered for best-in-class performance. It is compact, lightweight and features low headroom, making it ideal for operation in tight quarters. It is also designed with ergonomics in mind, helping to lessen fatigue and increase operator efficiency.

With a heavy-duty steel housing, the Zephyr has the durability needed for even the toughest lifting applications. It is shock resistant and virtually impervious to wear and tear in both normal and heavy-duty operating environments. It can also withstand extreme weather conditions, making it ideal for indoor or outdoor applications. Its simple design also makes it easy to service and maintain, ensuring reliable service and long life.

Adaptable to a variety of industries, the Chester Zephyr is a versatile hoist for any material handling application.

TABLE OF CONTENTS

4	HOOK-SUSPENDED HOISTS	22	TWIN-HOOK HOISTS	36	SPECIAL APPLICATIONS Oil & Gas Applications Clean Room Applications
8	CLEVIS-CONNECTED HOISTS & TROLLEYS	24	EXTENDED HANDWHEEL HOISTS	38	OTHER CHESTER PRODUCTS
10	ARMY-TYPE TROLLEY HOISTS	26	MODEL PT TROLLEYS	42	ADDITIONAL INFORMATION
14	LOW-HEADROOM TROLLEY HOISTS	30	SWIVEL-TRUCK TROLLEYS		
18	SWIVEL-TRUCK LOW-HEADROOM TROLLEY HOISTS	34	ACCESSORIES		



ZEPHYR

HOOK-SUSPENDED HOISTS

CAPACITIES

1/2 to 25 Tons

LIFT

8 Feet Standard

OPTIONSSpark and Corrosion Resistance
Clean Room

Chester Zephyr steel-framed, hook-suspended hoists are designed, built and tested to meet rigid quality and performance specifications that exceed industry standards. The Zephyr is a specially engineered hoist from every standpoint and is available in capacities ranging from ¼ to 25 tons. Versatile and easy to maintain, this hoist is durable and well suited to any lifting application.

KEY FEATURES**MECHANICALLY-SEALED,
GREASE-TIGHT ENCLOSURE**

Heavy steel housings keep out most foreign material, protecting precision-machined working parts. Sealed enclosure keeps lubrication in, making the Chester Zephyr a lifetime-lubricated hoist under normal conditions. No protruding parts prevent snagging.

SHOCK RESISTANT

Stamped covers made of heavy-gauge steel, two rolled steel sections in the frame and strong alloy steel suspension provide durability and shock resistance.

EASY DISMANTLING

Using only a small wrench and screwdriver, operators can make periodic inspections or replace chains and parts with ease.

GEAR TRAIN

Center planetary system uses modified involute stub tooth form. Gear teeth are cut from solid alloy steel blanks and heat treated for added strength.

**DURABLE INTERNAL GEARS,
PINIONS & PINION SHAFTS**

Internal gears and pinions are made of nickel-chrome-molybdenum alloy steel. Internal gear is heat treated for durability and strength. Machine-cut teeth are heat treated and mounted on heavy-duty roller bearings. Gear and pinion shafts are made of rigidly mounted alloy steel and are surface hardened and ground.

PINION CAGE

Spline fitted to the steel load wheel shaft.

DRIVING SPINDLE

Made of nickel-chrome-molybdenum alloy steel with machine-cut teeth. Operates on heavy-duty bearings.

LOAD WHEEL

Heat-treated cast steel with spline fit to load shaft. Chain pockets are accurately formed, and load wheel can be reversed when new chain is installed to effect double life.

CHAIN STRIPPER

Ductile Iron.

LOAD BRAKE

Positive-action, Weston-type load brake with uniform composition lining and quiet-action, forged-alloy dual pawls.

LOAD CHAIN GUIDE

Completely shrouds load sheave, guides chain into load wheel and efficiently shields these parts from entry of foreign objects.

LOAD CHAIN

Made of durable steel. Links are precision formed to fit pockets of load wheel. Heat treated for high tensile strength and hardness.

HAND CHAIN GUIDE

Designed to eliminate fouling and permit angular pull on the hand chain.

TOP HOOK ASSEMBLY

Permits hoist to rock and swivel under load. Alloy crosshead rocks in rolled steel straps welded to frame. Alloy hook is heat treated. Drop-forged alloy steel hook will open before fracturing.

BOTTOM HOOK ASSEMBLY

Consists of forged alloy steel hook operating on thrust bearing with full swiveling action.

For Chester trolley options, see pages 26 through 33.

HOOK-SUSPENDED HOISTS

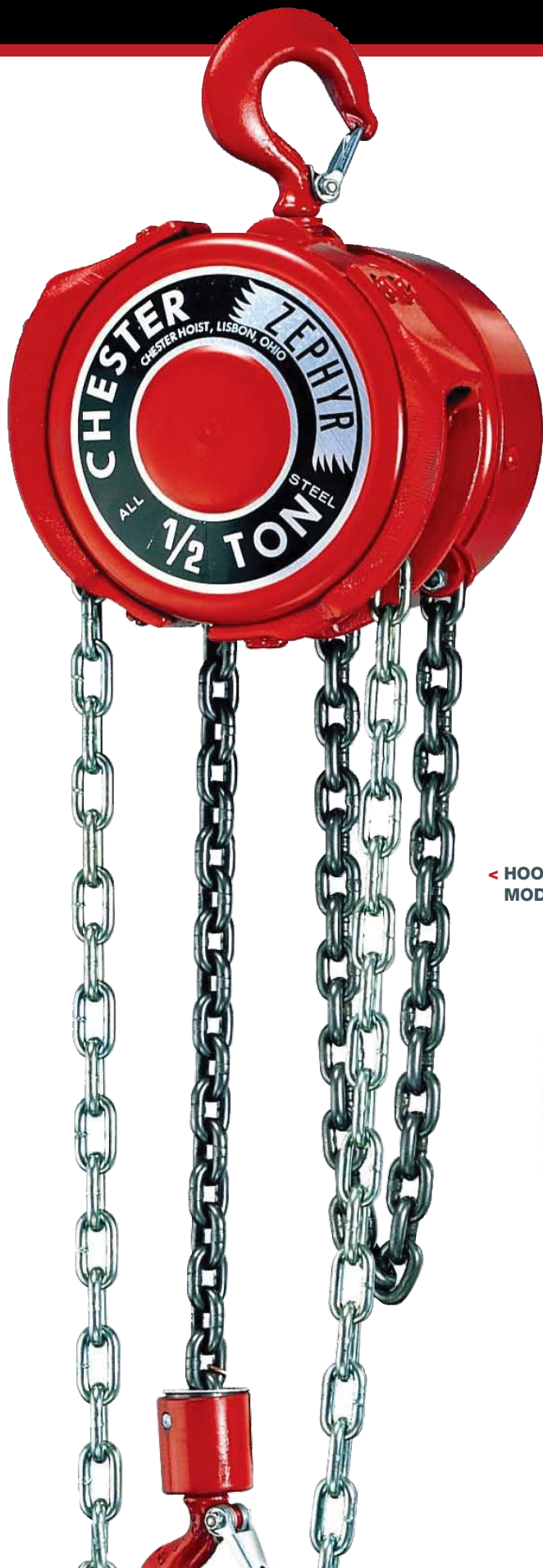

< **HOOK-SUSPENDED
MODEL**

SPARK-RESISTANT OPTIONS

**SOLID BRONZE TOP AND BOTTOM HOOKS,
BOTTOM BLOCK AND BRAKE RATCHET**

**STAINLESS STEEL LOAD CHAIN
AND HOOK LATCHES**

**ALUMINUM, BRONZE OR
STAINLESS STEEL HAND CHAIN**

CORROSION-RESISTANT OPTIONS

SPECIAL CORROSION-RESISTANT FINISHES

Created specifically for operation in salt-laden
or other corrosive environments.

CLEAN ROOM OPTIONS

**STAINLESS STEEL LOAD CHAIN, HAND
CHAIN, HAND CHAIN WHEEL, LIFT WHEEL,
HOOKS, LATCHES, HOOK BLOCK
AND HOUSINGS**

**GREASE-TIGHT ENCLOSURE
WITH FOOD-GRADE LUBRICANT**

Clean room environments exist in many industries,
including food processing, pharmaceutical, electronics
and others. Special material options available for the
Zephyr hoist allow it to be specially built and used in a
wide range of clean room applications.



< **SPARK-RESISTANT
HOOK-SUSPENDED
MODEL**

**CLEAN ROOM >
HOOK-SUSPENDED
MODEL**



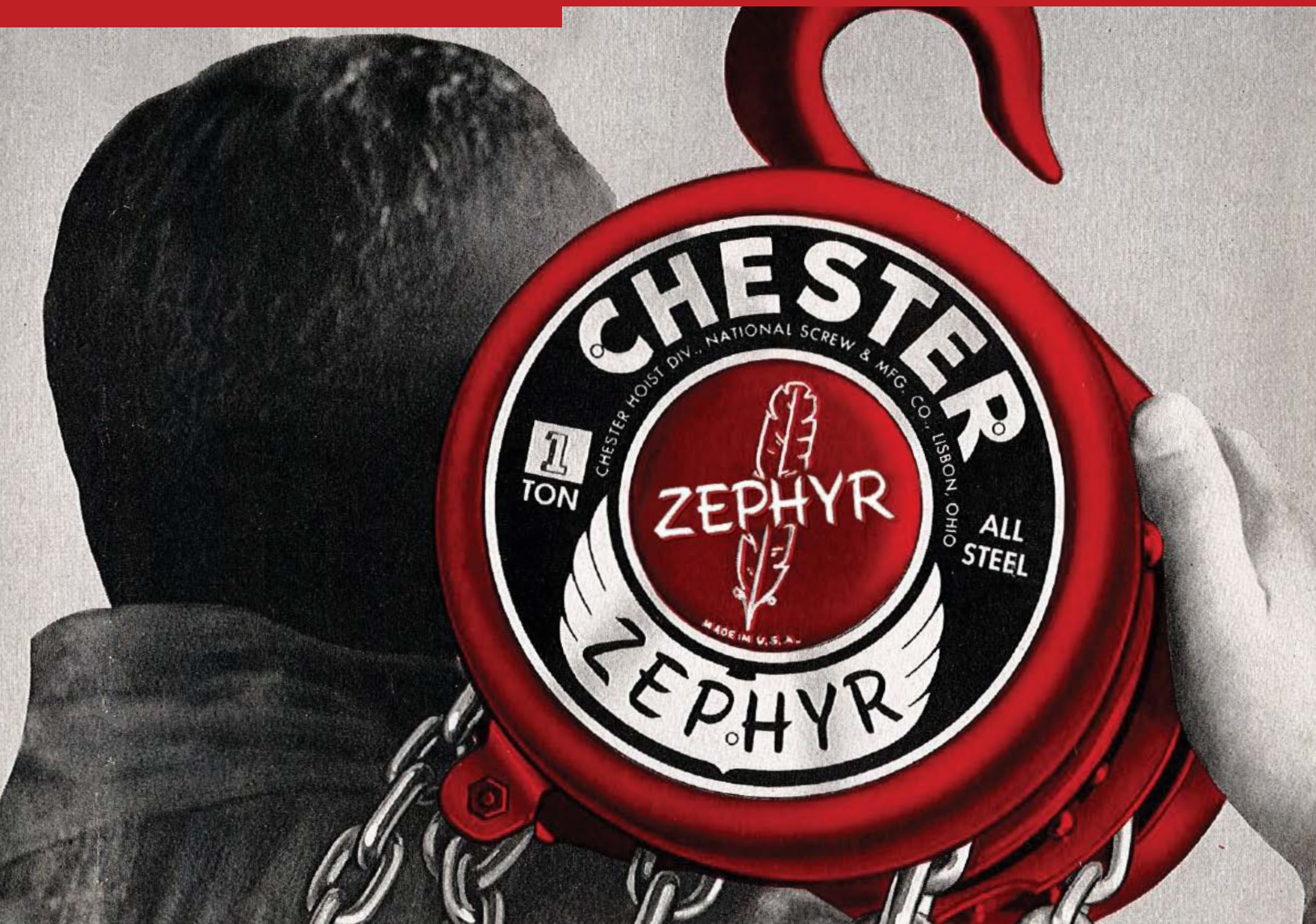

SPECIFICATIONS

Capacity (tons)	Catalog Number	Standard Lift (ft.)	Minimum Distance Between Hooks (in.)	Chain Pull to Lift Full Load (lbs.)	Chain Overhauled to Lift Load One Foot (ft.)	Strands of Chain		Length of Chain		Weight (lbs.)	
						Load	Hand	Load	Hand	Net	Gross
1/2	130-1/2	8	12-1/8	31	33	1	2	9' - 0"	14' - 0"	44	46
1	130 - 1	8	12-1/8	62	33	1	2	9' - 0"	14' - 0"	46	48
1-1/2	130 - 1-1/2	8	15-7/8	57	58	1	2	9' - 4"	14' - 6"	85	88
2	130 - 2	8	15-7/8	76	58	1	2	9' - 4"	14' - 6"	85	88
3	130 - 3	8	21-1/4	60	116	2	2	18' - 6"	15' - 6"	122	140
4	130 - 4	8	24-1/2	79	116	2	2	18' - 6"	15' - 6"	130	144
5	130 - 5	8	25-1/2	65	174	3	2	27' - 6"	15' - 6"	184	208
6	130 - 6	8	25-1/2	78	174	3	2	27' - 6"	15' - 6"	184	208
8	130 - 8	8	26-3/4	81	232	4	2	36' - 0"	16' - 0"	245	283
10	130 - 10	8	30-3/4	84	290	5	2	45' - 0"	16' - 6"	310	355
12	130 - 12	8	49-5/8	*78 (2)	*174	6	4	67' - 0"	(2) 19' - 0"	660	720
16	130 - 16	8	53-1/2	*81 (2)	*232	8	4	84' - 0"	(2) 19' - 0"	825	900
20	130 - 20	8	56-3/8	*85 (2)	*290	10	4	101' - 0"	(2) 19' - 0"	1050	1130
25	130 - 25	8	5 - 3/8	*93 (2)	*348	12	4	120' - 0"	(2) 19' - 0"	1070	1160

* One each hand chain. 12 Ton & up have two hand chains

A QUICK HISTORY

The Chester Manufacturing Company first launched the Zephyr hand chain hoist in 1956 as a lighter and more compact replacement for their “Model 41” hoist.

Because the Zephyr was designed and tested to the rigorous military standard, MIL-H-904, the hoist exceeded all applicable standards for the U.S. industrial hoist market. Building on its robust product platform, Chester introduced the first spark-resistant Zephyr hoist later that same year, which quickly became the hoist of choice for many users in the oil and gas industry.

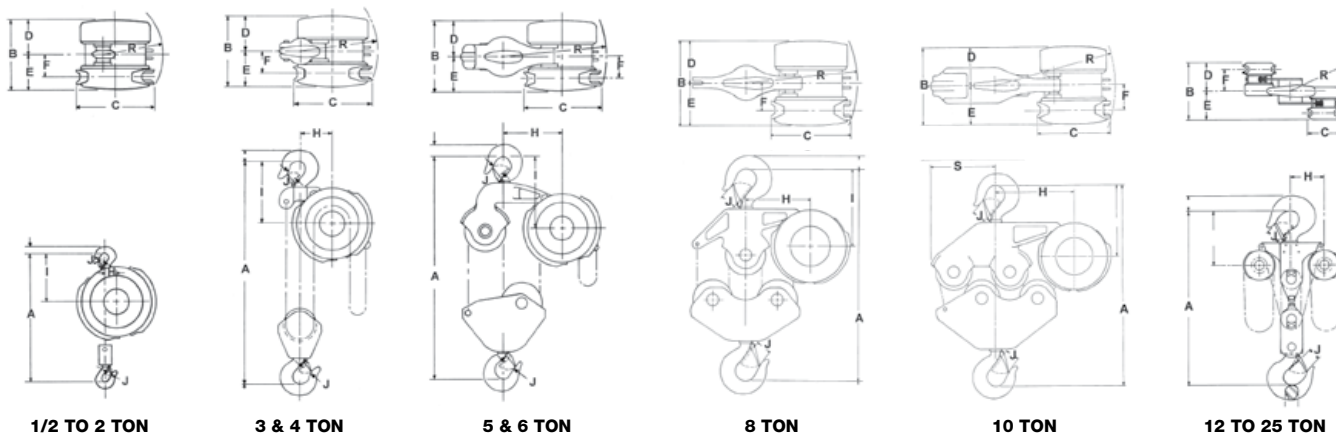

DIMENSIONS

Capacity (tons)	Dimensions (In.)										
	A	B	C	D	E	F	H	I	J	R	S
REGULAR UNITS											
1/2	12-1/8	8-1/2	8-3/4	4-1/4	4-1/4	3	1-3/8	6-7/16	1	7	–
1	12-1/8	8-1/2	8-3/4	4-1/4	4-1/4	3	1-3/8	6-7/16	1	7	–
1-1/2	15-7/8	10	11-1/2	5	5	3-1/4	1-3/4	7-5/8	1-1/8	8-1/2	–
2	15-7/8	10	11-1/2	5	5	3-1/4	1-3/4	7-5/8	1-1/8	8-1/2	–
3	23-1/2	10	11-1/2	5	5	3-1/4	4-7/8	9-1/8	1-11/32	11-1/2	–
4	24-1/2	10	11-1/2	5	5	3-1/4	4-7/8	9-5/8	1-11/16	11-1/2	–
5	25-1/2	10	11-1/2	5	5	3-1/4	6-3/8	10-1/2	1-11/16	13-1/2	–
6	25-1/2	10	11-1/2	5	5	3-1/4	6-3/8	10-1/2	1-11/16	13-1/2	–
8	26-3/4	10	11-1/2	5	5	3-1/4	8-1/2	11	2-1/16	14	–
10	30-3/4	10	11-1/2	5	5	3-1/4	10-1/4	10-5/8	2-1/4	17	9-1/4
12	49-5/8	14-5/8	11-1/2	7-5/16	7-5/16	5-9/16	11-1/8	13-9/16	3	18-1/2	–
16	53-1/2	16-3/8	11-1/2	8-3/16	8-3/16	6-7/16	11-1/8	15-1/8	3-5/8	18-3/4	–
20	56-3/8	18-1/4	11-1/2	9-1/8	9-1/8	7-3/8	11-1/8	15-1/8	3-5/8	19-3/16	–
25	56-3/8	20-1/8	11-1/2	10-1/16	10-1/16	8-5/16	11-1/8	15-1/8	3-5/8	19-11/16	–
SPARK-RESISTANT UNITS											
1/2	13	8-1/2	8-3/4	4-1/4	4-1/4	3	1-3/8	6-7/8	1	7	–
1	13	8-1/2	8-3/4	4-1/4	4-1/4	3	1-3/8	6-7/8	1	7	–
1-1/2	16-7/8	10	11-1/2	5	5	3-1/4	1-3/4	8-1/8	1-13/16	8-1/2	–
2	16-7/8	10	11-1/2	5	5	3-1/4	1-3/4	8-1/8	1-13/16	8-1/2	–
3	23-1/8	10	11-1/2	5	5	3-1/4	4-7/8	9-1/8	1-11/16	11-1/2	–
4	26-1/4	10	11-1/2	5	5	3-1/4	4-7/8	9-13/16	2-7/32	11-1/2	–
5	26-1/4	10	11-1/2	5	5	3-1/4	6-3/8	10-11/16	2-7/32	13-1/2	–
6	28-1/4	10	11-1/2	5	5	3-1/4	6-3/8	11-11/16	2-1/4	13-1/2	–
8	31-13/26	10	11-1/2	5	5	3-1/4	8-1/2	13-7/32	3-1/32	14	–
10	34-1/4	10	11-1/2	5	5	3-1/4	10-1/4	14-1/8	3-1/32	17	9-1/4
12	52-5/8	14-5/8	11-1/2	7-5/16	7-5/16	5-9/16	11-1/8	15-1/16	3-1/4	18-1/2	–
16	59	16-3/8	11-1/2	8-3/16	8-3/16	6-7/16	11-1/8	17-7/8	3-3/8	18-3/4	–
20	62-1/2	18-1/4	11-1/2	9-1/8	9-1/8	7-3/8	11-1/8	18-3/16	3-3/8	19-3/16	–
25	62-1/2	20-1/8	11-1/2	10-1/16	10-1/16	8-5/16	11-1/8	18-3/16	3-3/8	19-11/16	–

ZEPHYR CLEVIS-CONNECTED HOISTS & TROLLEYS

CAPACITIES

1/2 to 10 Tons

LIFT

8 Feet Standard

TROLLEY TYPES

Plain or Geared

OPTIONSSpark & Corrosion Resistance
Clean Room

Clevis-connected hoists and trolleys are ideal for applications where headroom limitations prohibit a standard trolley suspension or when you want to prevent casual removal of a hoist from the trolley. Design also retains rock-and-swivel flexibility of standard trolley suspension.

Any Zephyr hoist may be converted to clevis connected by removing the suspension hook, replacing with it with a clevis. These clevis-connected hoists may then be paired with a Chester Model PT trolley of the same capacity. See pages 26 through 29 for more information.

KEY FEATURES

CHESTER ZEPHYR CLEVIS-CONNECTED HOISTS & TROLLEYS CONTAIN ALL OF THE SAME KEY FEATURES AS THE HOOK-SUSPENDED MODELS.



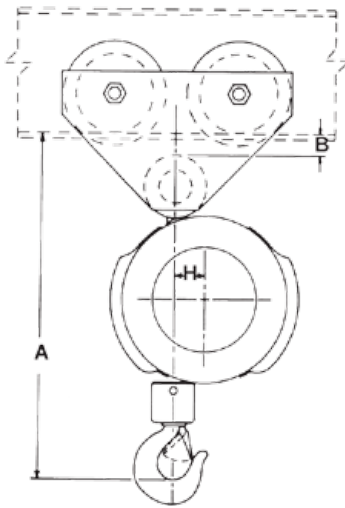

1/2 TO 2 TON

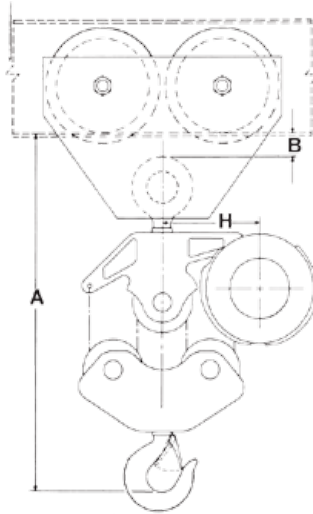

3 TO 10 TON

SPECIFICATIONS & DIMENSIONS

Capacity (tons)	Catalog Number	Standard Lift (ft.)	Minimum Headroom with Trolley (in.)	Adjustable For Standard I-Beam Size	Chain Pull to Lift Full Load One Foot (lbs.)	Chain Overhauled to Lift Load One Foot (ft.)	Net Weight with Trolley (lbs.)		Dimensions (in.)		
							Plain	Geared	A	B	C
REGULAR UNITS											
1/2	135 - 1/2	8	13-7/16	4 to 12	31	33	80	-	13-5/8	3/4	1-3/8
1	135 - 1	8	14-3/16	5 to 12	62	33	96	162	14-3/8	1-3/8	1-3/8
1-1/2	135 - 1-1/2	8	18-1/16	6 to 18	57	58	167	196	18-5/16	1-7/16	1-3/4
2	135 - 2	8	18-1/16	6 to 18	76	58	167	196	18-5/16	1-7/16	1-3/4
3	135 - 3	8	26	8 to 18	60	116	284	328	26-1/4	1-1/2	4-7/8
4	135 - 4	8	26-7/8	8 to 24	79	116	323	384	27-1/8	1-3/8	4-7/8
5	135 - 5	8	28-5/16	10 to 24	65	174	480	555	28-5/8	1-7/8	6-3/8
6	135 - 6	8	28-5/16	10 to 24	78	174	480	605	28-5/8	1-7/8	6-3/8
8	135 - 8	8	30-1/8	10 to 24	81	232	560	646	30-7/16	1-15/16	8-1/2
10	135 - 10	8	34	10 to 24	84	290	785	860	34-13/16	2-9/32	10-1/4
SPARK-RESISTANT UNITS											
1/2	13-7/8	8	13-7/8	4 to 12	31	33	80	-	13-5/8	3/4	1-3/8
1	14-5/8	8	14-5/8	5 to 12	62	33	96	162	14-3/8	1-3/8	1-3/8
1-1/2	18-9/16	8	18-9/16	6 to 18	57	58	167	196	18-5/16	1-7/16	1-3/4
2	18-9/16	8	18-9/16	6 to 18	76	58	167	196	18-5/16	1-7/16	1-3/4
3	-	8	-	8 to 18	60	116	284	328	26-1/4	1-1/2	4-7/8
4	27-3/4	8	27-3/4	8 to 24	79	116	323	384	27-1/8	1-3/8	4-7/8
5	28-11/16	8	28-11/16	10 to 24	65	174	480	555	28-5/8	1-7/8	6-3/8
6	29-11/16	8	29-11/16	10 to 24	78	174	480	605	28-5/8	1-7/8	6-3/8
8	32-21/32	8	32-21/32	10 to 24	81	232	560	646	30-7/16	1-15/16	8-1/2
10	35-3/4	8	35-3/4	10 to 24	84	290	785	860	34-13/16	2-9/32	10-1/4

ZEPHYR ARMY-TYPE TROLLEY HOISTS

CAPACITIES

1/2 to 10 Tons

LIFT

8 Feet Standard

TROLLEY TYPES

Plain or Geared

OPTIONSSpark and Corrosion Resistance
Clean Room

1/2 to 2 TON CAPACITY Zephyr army-type trolley hoists are uniquely and smartly designed for a variety of applications. They are relied on for their light weight and ability to traverse minimum radius curves freely, since the trolley units are built to swivel.

Construction is ingeniously simple. A standard Zephyr spur-gear hoist is suspended on a special load bar carried at each end by a lifetime-lubricated, precision-ball-bearing-equipped, two-wheel trolley. Trolley units are adjustable to beam size and interchangeable – plain trolley may be replaced with geared unit at any time, if required. Wheels have convex-machined treads that will maintain roundness through long-term use.

3 to 10 TON CAPACITY units are compact combinations of larger-capacity Zephyr spur geared hoists with integrated four-wheel trolleys, featuring sealed and tapered roller bearings. The result is a unit with minimal dimensions that retains full operating advantages of larger-scale units. The army-type construction not only provides protection for the heavy-gauge, rolled-steel side plates, but also allows for adjustability to beam sizes and adaptability to tight minimum radius track curves. All trolley wheels are easily adjustable for bearing wear.

FEATURES & BENEFITS

CHESTER ZEPHYR ARMY-TYPE TROLLEY HOISTS CONTAIN ALL OF THE SAME KEY FEATURES AS THE HOOK-SUSPENDED MODELS.

See page 4.

OPTIONAL FEATURES**TRACK CLAMPS****LOAD LIMITERS****TROLLEY BUMPERS AND DROP STOPS****CHAIN CONTAINERS**

< **1/2 TO 2 TON
MODELS**



3 TO 10 TON >
MODELS



3 TO 10 TON >
SPARK-RESISTANT
MODELS

SPARK-RESISTANT OPTIONS

**SOLID BRONZE BOTTOM HOOK,
BOTTOM BLOCK, BRAKE RATCHET
AND TROLLEY WHEELS**

STAINLESS STEEL LOAD CHAIN

**ALUMINUM OR STAINLESS STEEL
HAND CHAIN**

CORROSION-RESISTANT OPTIONS

SPECIAL CORROSION-RESISTANT FINISHES

Created specifically for operation in salt-laden or other corrosive environments.

CLEAN ROOM OPTIONS

STAINLESS STEEL COMPONENTS

**GREASE-TIGHT ENCLOSURE WITH
FOOD-GRADE LUBRICANT**

FOOD-GRADE EPOXY FINISH

SPECIFICATIONS

Capacity (tons)	Catalog Number		Standard Lift (ft.)	Minimum Headroom (in.)	Radius Curve (lbs.) *	For Standard I-Beam Size **	Weight (lbs.)			
	Plain	Geared					Net		Gross	
							Plain	Geared	Plain	Geared
1/2	1311 - 1/2	1312 - 1/2	8	10-3/4	21	S4" - S10" x 25.4#	94	139	115	160
1	1311 - 1	1312 - 1	8	10-7/8	21	S5" - S10" x 25.4#	109	145	130	164
1-1/2	1311 - 1-1/2	1312 - 1-1/2	8	13-1/2	30	S6" - S15" x 42.9#	169	194	208	240
2	1311 - 2	1312 - 2	8	13-1/2	30	S6" - S15" x 42.9#	169	194	208	240
3	1311 - 3	1312 - 3	8	19-5/8	36	S8" - S18" x 54.7#	220	260	246	300
4	1311 - 4	1312 - 4	8	20-1/8	36	S8" - S24" x 90#	274	295	300	340
5	1311 - 5	1312 - 5	8	23-1/2	48	S10" - S20" x 66#	375	400	405	445
6	1311 - 6	1312 - 6	8	23-1/2	48	S10" - S20" x 66#	375	400	405	445
8	1311 - 8	1312 - 8	8	24-5/8	84	S10" - S24" x 121#	523	563	558	605
10	1311 - 10	1312 - 10	8	25	90	S12" - S24" x 121#	673	703	725	773

Zephyr Army Type Hoists are available for wide flange sections, monorail runways, or I-beams outside the normal adjustment range. Consult factory for details.

* Radius must be specified on each order. Wheels may require modification for some curves.

** Beams listed are for proper wheel clearance only. The customer must verify his selected beam is adequate for his application.

ZEPHYR ARMY-TYPE TROLLEY HOISTS

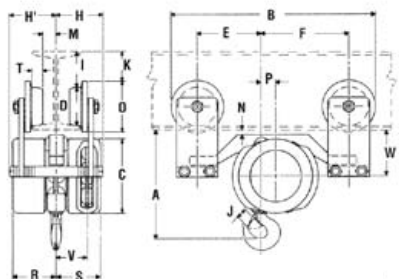

**1/2 TO 2 TON
PLAIN**

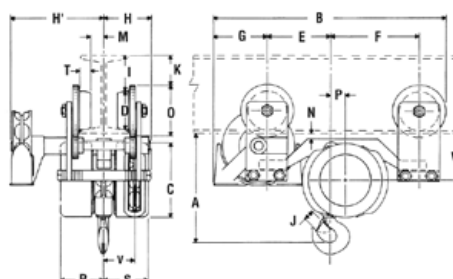

**1 TO 2 TON
GEARED**

DIMENSIONS

Capacity (tons)	Dimensions (In.)																				
	A	B	C	D	E	F	H	H'	I	J	K	L	M	N	O	P	R	S	T	V	W
PLAIN TROLLEY HOIST																					
1/2	10-7/8	18-3/8	7-1/4	2-7/8	6-1/8	8-5/8	4-1/4	-	13/16	1	7/16	-	1/2	5/8	3-5/8	1-3/8	4-1/4	4-1/4	7/8	3	4-9/16
1	10-7/8	19-3/4	7-1/4	3-3/4	6-1/8	8-5/8	4-5/8	-	15/16	1	5/16	-	1/2	5/8	5	1-3/8	4-1/4	4-1/4	1-1/16	3	4-9/16
1-1/2	13-1/2	24-1/2	9-3/4	4-1/2	7-1/2	11	5	-	1	1-1/8	5/16	-	11/16	7/16	6	1-3/4	5	5	1-7/64	3-1/4	5-7/16
2	13-1/2	24-1/2	9-3/4	4-1/2	7-1/2	11	5	-	1	1-1/8	5/16	-	11/16	7/16	6	1-3/4	5	5	1-7/64	3-1/4	5-7/16
PLAIN TROLLEY HOIST, SPARK-RESISTANT																					
1/2	11-1/8	18-3/8	7-1/4	2-7/8	6-1/8	8-5/8	4-1/4	-	13/16	1	7/16	-	1/2	5/8	3-5/8	1-3/8	4-1/4	4-1/4	7/8	3	4-9/16
1	11-1/8	19-3/4	7-1/4	3-3/4	6-1/8	8-5/8	4-5/8	-	15/16	1	5/16	-	1/2	5/8	5	1-3/8	4-1/4	4-1/4	1-1/16	3	4-9/16
1-1/2	14-1/2	24-1/2	9-3/4	4-1/2	7-1/2	11	5	-	1	1-13/32	5/16	-	11/16	7/16	6	1-3/4	5	5	1-7/64	3-1/4	5-7/16
2	14-1/2	24-1/2	9-3/4	4-1/2	7-1/2	11	5	-	1	1-13/32	5/16	-	11/16	7/16	6	1-3/4	5	5	1-7/64	3-1/4	5-7/16

Capacity (tons)	Dimensions (In.)																				
	A	B	C	D	E	F	G	H	H'	I	J	K	M	N	O	P	R	S	T	V	W
GEARED TROLLEY HOIST																					
1	10-7/8	22-1/2	7-1/4	3-3/4	6-1/8	8-5/8	5-1/4	4-13/16	8-5/8	15/16	1	5/16	1/2	5/8	5	1-3/8	4-1/4	4-1/4	1-1/16	3	4-9/16
1-1/2	13-1/2	27-1/4	9-3/4	4-1/2	7-1/2	11	5-3/4	4-9/16	8-7/8	1	1-1/8	5/16	11/16	7/16	6	1-3/4	5	5	1-7/64	3-1/4	5-7/16
2	13-1/2	27-1/4	9-3/4	4-1/2	7-1/2	11	5-3/4	4-9/16	8-7/8	1	1-1/8	5/16	11/16	7/16	6	1-3/4	5	5	1-7/64	3-1/4	5-7/16
GEARED TROLLEY HOIST, SPARK-RESISTANT																					
1	11-1/8	22-1/2	7-1/4	3-3/4	6-1/8	8-5/8	5-1/4	4-13/16	8-5/8	15/16	1	5/16	1/2	5/8	5	1-3/8	4-1/4	4-1/4	1-1/16	3	4-9/16
1-1/2	14-1/2	27-1/4	9-3/4	4-1/2	7-1/2	11	5-3/4	4-9/16	8-7/8	1	1	5/16	11/16	7/16	6	1-3/4	5	5	1-7/64	3-1/4	5-7/16
2	14-1/2	27-1/4	9-3/4	4-1/2	7-1/2	11	5-3/4	4-9/16	8-7/8	1	1-13/32	5/16	11/16	7/16	6	1-3/4	5	5	1-7/64	3-1/4	5-7/16

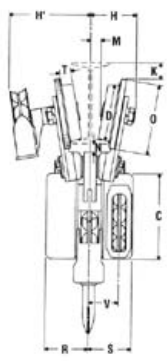

**3 & 4 TON
PLAIN & GEARED**

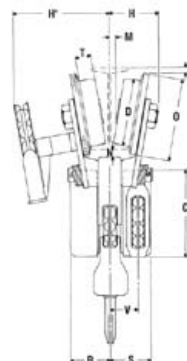
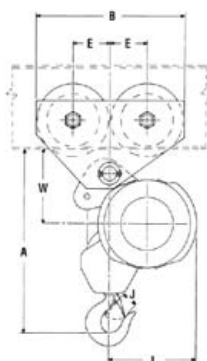

**5 & 6 TON
PLAIN & GEARED**

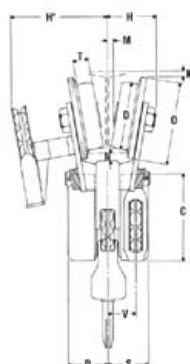
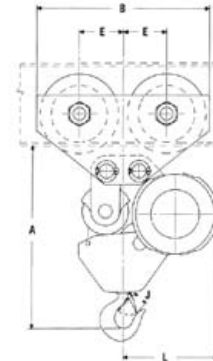

**8 TON
PLAIN & GEARED**

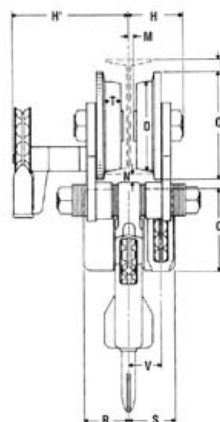
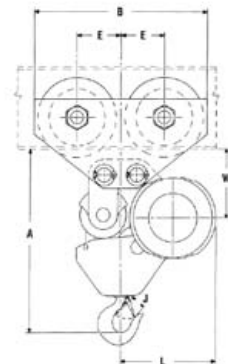

**10 TON
PLAIN & GEARED**

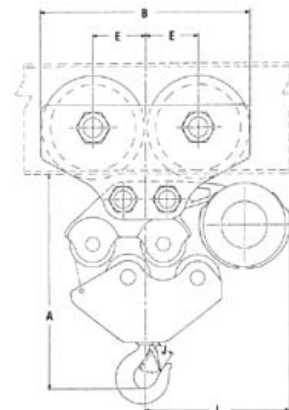

DIMENSIONS

Capacity (tons)	Dimensions (In.)																				
	A	B	C	D	E	F	H	H'	I	J	K	L	M	N	O	P	R	S	T	V	W
PLAIN & GEARED TROLLEY HOIST																					
3	19-5/8	16-3/4	9-3/4	6-3/8	4-1/4	-	5-1/8	11	-	1-11/32	5/8	11	3/4	1-1/8	8	-	5	5	1-5/16	3-1/4	8-1/4
4	20-1/8	16-3/4	9-3/4	6-3/8	4-1/4	-	5-1/8	11	-	1-11/16	5/8	11	3/4	1-1/8	8	-	5	5	1-5/16	3-1/4	8-1/4
5	23-1/2	19-1/2	9-3/4	7-3/16	5	-	5-3/4	13-1/16	-	1-11/16	1-5/8	11-7/8	1-1/8	1	9	-	5	5	1-7/16	3-1/4	8-5/8
6	23-1/2	19-1/2	9-3/4	7-3/16	5	-	5-3/4	13-1/16	-	1-11/16	1-5/8	11-7/8	1-1/8	1	9	-	5	5	1-7/16	3-1/4	8-5/8
8	24-5/8	21	9-3/4	8-1/4	5-1/4	-	6-1/4	13-1/2	-	2-1/16	3/8	14	1/2	1-3/4	10	-	5	5	1-11/16	3-1/4	8-5/8
10	25	23-3/4	9-3/4	9-3/4	6	-	6-1/4	12-3/4	-	2-1/4	7/8	16-1/2	1/2	3/4	11-11/16	-	5	5	1-3/4	3-1/4	6-1/2
PLAIN & GEARED TROLLEY HOIST , SPARK-RESISTANT																					
3	22-1/4	16-3/4	9-3/4	6-3/8	4-1/4	-	5-1/8	11	-	1-11/32	5/8	11	3/4	1-1/8	8	-	5	5	1-5/16	3-1/4	8-1/4
4	23-3/8	16-3/4	9-3/4	6-3/8	4-1/4	-	5-1/8	11	-	1-11/16	5/8	11	3/4	1-1/8	8	-	5	5	1-5/16	3-1/4	8-1/4
5	24-3/4	19-1/2	9-3/4	7-3/16	5	-	5-3/4	13-1/16	-	1-11/16	1-5/8	11-7/8	1-1/8	1	9	-	5	5	1-7/16	3-1/4	8-5/8
6	25-1/4	19-1/2	9-3/4	7-3/16	5	-	5-3/4	13-1/16	-	1-11/16	1-5/8	11-7/8	1-1/8	1	9	-	5	5	1-7/16	3-1/4	8-5/8
8	29-9/16	21	9-3/4	8-1/4	5-1/4	-	6-1/4	13-1/2	-	2-1/16	3/8	14	1/2	1-3/4	10	-	5	5	1-11/16	3-1/4	8-5/8
10	30-3/8	23-3/4	9-3/4	9-3/4	6	-	6-1/4	12-3/4	-	2-1/4	7/8	16-1/2	1/2	3/4	11-11/16	-	5	5	1-3/4	3-1/4	6-1/2

For 3 through 10 Ton, dimensions H, H' and K vary directly as the beam varies.

ZEPHYR LOW-HEADROOM TROLLEY HOISTS

CAPACITIES

1-1/2 to 24 Tons

LIFT

8 Feet Standard

OPTIONS

Spark & Corrosion Resistance
Clean Room

Chester Zephyr low-headroom trolley hoists, as the name implies, are designed for applications where head room is very limited, preventing the use of standard hoists. They are ideal for existing structures with low ceilings as well as new construction where low ceilings are required. These low-headroom hoists are equipped with concentrically machined, cast iron, precision bearing trolley wheels.

Each Zephyr low-headroom hoist is custom built to fit the beam size, flange width and curve radius for the specific application.

KEY FEATURES

CHESTER ZEPHYR LOW-HEADROOM TROLLEY HOISTS CONTAIN ALL OF THE SAME KEY FEATURES AS THE HOOK-SUSPENDED MODELS.

POSITIVE ENGAGEMENT RACK & PINION OR SPROCKET & ROLLER CHAIN TROLLEY DRIVES

Available for use on inclined monorails or for shipboard use to provide increased control over the trolley to prevent unintended movement.



▲ RACK & PINION TROLLEY DRIVE

SPECIFICATIONS

Capacity (short tons)	Catalog Number		Standard Lift (ft.)	Load Chain Length (2 Chains per Hoist)	Minimum Radius Curve ††	Minimum Distance from Bottom of I-Beam to Hook (in.)	Chain Pull to Lift Full Load (lbs.)	Chain Overhauled to Lift Load One Foot (ft.)	Weight (lbs.)	
	Plain Trolley	Geared Trolley							Net	Gross
1-1/2	1421 - 1-1/2	1422 - 1-1/2	8	9'-6"	6'-6"	6-1/4	41	87	207	230
2	1421 - 2	1422 - 2	8	9'-6"	6'-6"	6-1/4	54	87	210	233
3	1421 - 3	1422 - 3	8	18'-3"	6'-6"	7-3/8	42	176	305	335
4	1421 - 4	1422 - 4	8	18'-3"	7'-6"	8	56	176	308	340
5	1421 - 5	1422 - 5	8	10'	8'-6"	8-3/4	79	165	574	633
6	1421 - 6	1422 - 6	8	10'	8'-6"	8-3/4	94	165	574	633
8	1421 - 8	1422 - 8	8	19'	9'-6"	11	64	355	650	773
10	1421 - 10	1422 - 10	8	19'-6"	10'	11-1/2	87	330	1022	1105
12	1421 - 12	1422 - 12	8	19'-6"	†	11-1/2	104	330	1022	1105
16	1421 - 16	1422 - 16	8	38'-6"	†	13-5/8	68	710	1600	1681
20	1421 - 20	1422 - 20	8	39'	†	17-1/4	87	731-1/2	1950	2110
24	1421 - 24	1422 - 24	8	39'	†	17-1/4	104	731-1/2	1950	2110

ALL HEADROOM DIMENSIONS DETERMINED WHILE HOIST UNDER LOAD.

† Straight track operation only recommended for these units.

†† Curves less than minimum may be fitted by special construction. Consult factory.

Curve radius must be specified on order since wheels are modified to negotiate curves.



◀ STANDARD MODEL

SPARK-RESISTANT OPTIONS

SOLID BRONZE HOOK, BOTTOM BLOCK, BRAKE RATCHET AND TROLLEY WHEELS

STAINLESS STEEL LOAD CHAIN

ALUMINUM OR STAINLESS STEEL HAND CHAIN

CORROSION-RESISTANT OPTIONS

SPECIAL CORROSION-RESISTANT FINISHES

Created specifically for operation in salt-laden or other corrosive environments.

CLEAN ROOM OPTIONS

STAINLESS STEEL COMPONENTS

GREASE-TIGHT ENCLOSURE WITH FOOD-GRADE LUBRICANT

FOOD-GRADE EPOXY FINISH

OPTIONAL FEATURES

TRACK CLAMPS

LOAD LIMITERS

CHAIN CONTAINERS

SPARK AND CORROSION RESISTANCE

POSITIVE ENGAGEMENT RACK & PINION OR SPROCKET & ROLLER CHAIN TROLLEY DRIVES

Available for use on inclined monorails or for shipboard use to provide increased control over the trolley to prevent unintended movement.



◀ SPARK-RESISTANT MODEL

ZEPHYR LOW-HEADROOM TROLLEY HOISTS

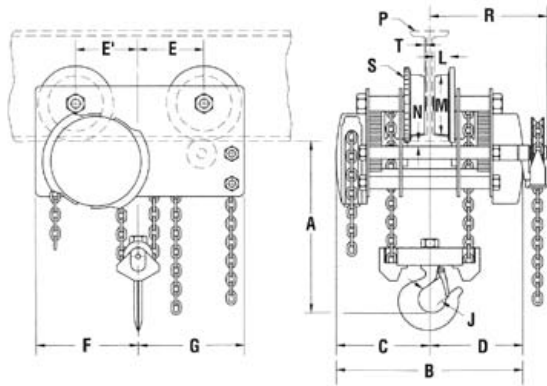

PLAIN & GEARED

DIMENSIONS

Capacity (tons)	Dimensions (In.)															
	A	B	C	D	E	E'	F	G	H	J	L	M	N**	P*	R	S
PLAIN & GEARED TROLLEY HOIST																
1-1/2	6-1/4	20-3/8	10-3/16	10-3/16	5-1/8	5-1/8	8-3/4	8-1/4	5/8	1-1/8	1-1/8	4-1/2	1/2	6" I @ 12.5#	13-1/16	6
2	6-1/4	20-3/8	10-3/16	10-3/16	5-1/8	5-1/8	8-3/4	8-1/4	5/8	1-1/8	1-1/8	4-1/2	1/2	6" I @ 12.5#	13-1/16	6
3	7-3/8	20-3/8	10-3/16	10-3/16	6-1/2	6-5/8	10-5/8	10-5/8	9/16	1-11/32	1-11/32	6-3/8	1/2	8" I @ 18.4#	13-1/16	8
4	8	20-3/8	10-3/16	10-3/16	6-1/2	6-5/8	10-5/8	10-5/8	9/16	1-11/16	1-11/32	6-3/8	1/2	8" I @ 18.4#	13-1/16	8
5	8-3/4	26-1/4	13-1/8	13-1/8	7-3/8	7-3/8	12	12	29/32	1-11/16	1-13/32	7-3/16	9/16	10" I @ 25.4#	16-1/2	9
6	8-3/4	26-1/4	13-1/8	13-1/8	7-3/8	7-3/8	12	12	29/32	1-11/16	1-13/32	7-3/16	9/16	10" I @ 25.4#	16-1/2	9
8	11	26-1/4	13-1/8	13-1/8	8-3/8	8-7/8	14	13-1/2	9/16	2-1/16	1-11/16	8-1/4	9/16	10" I @ 25.4#	16-1/2	10
10	11-1/2	26-1/4	13-1/8	13-1/8	8-1/2	9-3/4	15-5/8	14-3/8	9/16	2-1/4	1-3/4	9-3/4	5/8	12" I @ 31.8#	16-1/2	11-11/16
12	11-1/2	26-1/4	13-1/8	13-1/8	8-1/2	9-3/4	15-5/8	14-3/8	9/16	2-1/4	1-3/4	9-3/4	5/8	12" I @ 31.8#	16-1/2	11-11/16
16	13-5/8	30-3/8	15-3/16	15-3/16	11-7/8	11-7/8	18-5/8	18-5/8	9/16	3	2	11-3/4	3/4	15" I @ 42.9#	18-7/8	13-1/2
20	17-1/4	30-3/8	15-3/16	15-3/16	12-1/8	12-3/8	19-1/4	19	3/4	3-5/8	2	11-3/4	5/8	18" I @ 54.7#	18-7/16	13-1/2
24	17-1/4	30-3/8	15-3/16	15-3/16	12-1/8	12-3/8	19-1/4	19	3/4	3-5/8	2	11-3/4	5/8	18" I @ 54.7#	18-7/16	13-1/2
PLAIN & GEARED TROLLEY HOIST, SPARK-RESISTANT																
1-1/2	7-3/8	20-3/8	10-3/16	10-3/16	5-1/8	5-1/8	8-3/4	8-1/4	5/8	1-11/32	1-1/8	4-1/2	1/2	6" I @ 12.5#	13-1/16	6
2	7-3/8	20-3/8	10-3/16	10-3/16	5-1/8	5-1/8	8-3/4	8-1/4	5/8	1-11/32	1-1/8	4-1/2	1/2	6" I @ 12.5#	13-1/16	6
3	8-7/16	20-3/8	10-3/16	10-3/16	6-1/2	6-5/8	10-5/8	10-5/8	9/16	1-11/16	1-11/32	6-3/8	1/2	8" I @ 18.4#	13-1/16	8
4	9-15/16	20-3/8	10-3/16	10-3/16	6-1/2	6-5/8	10-5/8	10-5/8	9/16	2-7/32	1-11/32	6-3/8	1/2	8" I @ 18.4#	13-1/16	8
5	10-5/16	26-1/4	13-1/8	13-1/8	7-3/8	7-3/8	12	12	29/32	2-7/32	1-13/32	7-3/16	9/16	10" I @ 25.4#	16-1/2	9
6	11-3/8	26-1/4	13-1/8	13-1/8	7-3/8	7-3/8	12	12	29/32	2-1/4	1-13/32	7-3/16	9/16	10" I @ 25.4#	16-1/2	9
8	14-1/16	26-1/4	13-1/8	13-1/8	8-3/8	8-7/8	14	13-1/2	9/16	3-1/32	1-11/16	8-1/4	9/16	10" I @ 25.4#	16-1/2	10
10	14-7/16	26-1/4	13-1/8	13-1/8	8-1/2	9-3/4	15-5/8	14-3/8	9/16	3-1/32	1-3/4	9-3/4	5/8	12" I @ 31.8#	16-1/2	11-11/16
12	16-1/8	26-1/4	13-1/8	13-1/8	8-1/2	9-3/4	15-5/8	14-3/8	9/16	3-1/4	1-3/4	9-3/4	5/8	12" I @ 31.8#	16-1/2	11-11/16
16	19-5/16	30-3/8	15-3/16	15-3/16	11-7/8	11-7/8	18-5/8	18-5/8	9/16	3-3/8	2	11-3/4	3/4	15" I @ 42.9#	18-7/8	13-1/2
20	20-1/4	30-3/8	15-3/16	15-3/16	12-1/8	12-3/8	19-1/4	19	3/4	3-3/8	2	11-3/4	5/8	18" I @ 54.7#	18-7/16	13-1/2
24	20-1/4	30-3/8	15-3/16	15-3/16	12-1/8	12-3/8	19-1/4	19	3/4	3-3/8	2	11-3/4	5/8	18" I @ 54.7#	18-7/16	13-1/2

For over 10 Ton, straight track operation is recommended.

Curve radius must be specified on orders.

Curves less than minimum radius may be fitted upon application.

* Minimum Standard I-Beam for Proper Wheel Running Clearance Only.

** At Under Beam Roller

Customer must verify their beam is adequate for the applied loads.

CHESTER

CHESTER HOIST, LISBON, OHIO

ZEPHYR

ALL

STEEL

2 TON



ZEPHYR

SWIVEL-TRUCK LOW-HEADROOM TROLLEY HOISTS

CAPACITIES

1/4 to 6 Tons

LIFT

8 Feet Standard

**MINIMUM
RADIUS CURVE**

21 to 48 in.

OPTIONSSpark & Corrosion Resistance
Clean Room

Chester Zephyr swivel-truck, low-headroom trolley hoists maintain the absolute minimum distance between the bottom of the runway beam and the hook saddle in the uppermost position, making them well suited for use in tight spaces. Hoists are available in capacities ranging from 1/4 to 6 tons with either plain or hand-gearred trolleys.

These Zephyr hoists combine the benefits of the Chester swivel truck trolley design with a compact construction. The units also incorporate the same heavy-duty steel components common to our Zephyr product line to provide the ruggedness and durability required for your application.

Zephyr swivel-truck, low-headroom trolley hoists are designed to traverse tight curves without binding or scraping and, due to their compact design, runways can be built closer to walls or projections. With extremely low headroom, these hoists are ideal for existing structures with low ceilings and as well as new construction where low ceilings are required. They are also ideal for patented monorail applications where minimum headroom is required with interlocks, turntables or switches.

Swivel-truck, low-headroom Zephyr hoists are adaptable to most monorail systems as well as other types of rails. Units are available with track clamps, load limiters, chain containers and an assortment of other options including spark and corrosion resistance, as required.



◀ STANDARD MODEL

SPARK-RESISTANT OPTIONS

SOLID BRONZE HOOK, BOTTOM BLOCK, BRAKE RATCHET AND TROLLEY WHEELS

STAINLESS STEEL LOAD CHAIN

ALUMINUM OR STAINLESS STEEL HAND CHAIN

CORROSION-RESISTANT OPTIONS

SPECIAL CORROSION-RESISTANT FINISHES

Created specifically for operation in salt-laden or other corrosive environments.

CLEAN ROOM OPTIONS

STAINLESS STEEL COMPONENTS

GREASE-TIGHT ENCLOSURE WITH FOOD-GRADE LUBRICANT

FOOD-GRADE EPOXY FINISH

SPECIFICATIONS

Capacity (short tons)	Catalog Number		Standard Lift (ft.)	Minimum Radius Curve (in.)	Minimum Beam Size *	Distance from Beam to Hook Saddle (in.)	Chain Pull to Lift Full Load (lbs.)	Chain Overhauled to Lift Load One Foot (ft.)	Weight (lbs.)	
	Plain Trolley	Gearred Trolley							Net	Gross
1/4	1321 - 1/4	1322 - 1/4	8	21	S5" x 10.0#	6-3/16	17	33	127	144
1/2	1321 - 1/2	1322 - 1/2	8	21	S5" x 10.0#	6-3/16	35	33	127	144
1	1321 - 1	1322 - 1	8	21	S5" x 10.0#	6-3/16	70	33	127	144
1-1/2	1321 - 1-1/2	1322 - 1-1/2	8	30	S6" x 12.5#	6-3/4	57	66	245	267
2	1321 - 2	1322 - 2	8	30	S6" x 12.5#	6-3/4	76	66	251	270
3	1321 - 3	1322 - 3	8	42	S8" x 18.4#	8-1/4	42	170	345	375
4	1321 - 4	1322 - 4	8	42	S8" x 18.4#	9-1/4	58	170	350	380
5	1321 - 5	1322 - 5	8	48	S10" x 25.4#	9-15/16	73	170	466	496
6	1321 - 6	1322 - 6	8	48	S10" x 25.4#	9-15/16	90	170	466	496

Beam size and curve radius must always be specified when ordering.

* Minimum beam for wheel clearance only.

Customer must verify their beam is adequate for the applied loading.

ZEPHYR SWIVEL-TRUCK LOW-HEADROOM TROLLEY HOISTS

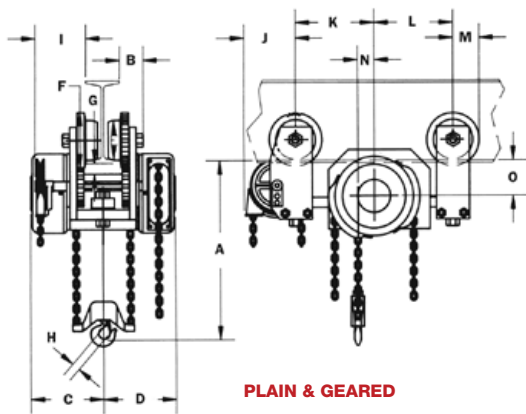

PLAIN & GEARED

MAXIMUM FLANGE WIDTHS

Capacity (tons)	Maximum Flange Width And Thickness FOR STRAIGHT TRACK	Maximum Flange Width And Thickness FOR MINIMUM RADIUS TRACK
1/4	5-3/8" W. x 1/2" Thk.	3-3/8" W. x 1/2" Thk.
1/2	5-3/8" W. x 1/2" Thk.	3-3/8" W. x 1/2" Thk.
1	5-3/8" W. x 1/2" Thk.	3-3/8" W. x 1/2" Thk.
1-1/2	6" W. x 5/8" Thk.	4" W. x 1/2" Thk.
2	6" W. x 5/8" Thk.	4" W. x 1/2" Thk.
3	6" W. x 5/8" Thk.	5-7/8" W. x 5/8" Thk.
4	6" W. x 5/8" Thk.	5-7/8" W. x 5/8" Thk.
5	8" W. x 7/8" Thk.	7-7/8" W. x 7/8" Thk.
6	8" W. x 7/8" Thk.	7-7/8" W. x 7/8" Thk.

DIMENSIONS

Capacity (tons)	Dimensions (In.)															
	A	B	C	D	E	F	Plain G	Geared G	H	I*	J*	K	L	M	N	O
PLAIN & GEARED TROLLEY HOIST																
1/4	6-3/16	2	6-9/16	6-9/16	3-3/4	5	7/8	7/8	31/32	4-11/16	3-3/4	7-1/4	6-1/2	2-1/2	1-3/8	2-15/16
1/2	6-3/16	2	6-9/16	6-9/16	3-3/4	5	7/8	7/8	31/32	4-11/16	3-3/4	7-1/4	6-1/2	2-1/2	1-3/8	2-15/16
1	6-3/16	2	6-9/16	6-9/16	3-3/4	5	7/8	7/8	31/32	4-11/16	3-3/4	7-1/4	6-1/2	2-1/2	1-3/8	2-15/16
1-1/2	6-3/4	2-3/16	8-11/16	8-11/16	4-1/2	6	5/8	5/8	1-1/8	7-3/16	6-1/4	11-3/8	7-5/8	3	3	1-7/8
2	6-3/4	2-3/16	8-11/16	8-11/16	4-1/2	6	5/8	5/8	1-1/8	7-3/16	6-1/4	11-3/8	7-5/8	3	3	1-7/8
3	8-1/4	2-9/16	9-7/8	9-7/8	6-3/8	8	15/16	15/16	1-11/32	8-1/8	6-1/8	11-9/16	7-11/16	4	3	3-7/16
4	9-1/4	2-9/16	9-7/8	9-7/8	6-3/8	8	15/16	15/16	1-11/32	8-1/8	6-1/8	11-9/16	7-11/16	4	3	3-7/16
5	9-15/16	2-13/16	10-1/8	10-1/8	7-3/16	9	7/8	7/8	1-11/16	8-1/2	6-15/16	11-9/16	8-13/16	4-1/2	3	3-7/8
6	9-15/16	2-13/16	10-1/8	10-1/8	7-3/16	9	7/8	7/8	1-11/16	8-1/2	6-15/16	11-9/16	8-13/16	4-1/2	3	3-7/8
PLAIN & GEARED TROLLEY HOIST, SPARK-RESISTANT																
1/4	6-13/16	2	6-9/16	6-9/16	3-3/4	5	7/8	7/8	31/32	4-11/16	3-3/4	7-1/4	6-1/2	2-1/2	1-3/8	2-15/16
1/2	6-13/16	2	6-9/16	6-9/16	3-3/4	5	7/8	7/8	31/32	4-11/16	3-3/4	7-1/4	6-1/2	2-1/2	1-3/8	2-15/16
1	6-13/16	2	6-9/16	6-9/16	3-3/4	5	7/8	7/8	31/32	4-11/16	3-3/4	7-1/4	6-1/2	2-1/2	1-3/8	2-15/16
1-1/2	7-7/16	2-3/16	8-11/16	8-11/16	4-1/2	6	5/8	5/8	1-1/8	7-3/16	6-1/4	11-3/8	7-5/8	3	3	1-7/8
2	7-7/16	2-3/16	8-11/16	8-11/16	4-1/2	6	5/8	5/8	1-1/8	7-3/16	6-1/4	11-3/8	7-5/8	3	3	1-7/8
3	9-9/16	2-9/16	9-7/8	9-7/8	6-3/8	8	15/16	15/16	1-11/32	8-1/8	6-1/8	11-9/16	7-11/16	4	3	3-7/16
4	10-11/16	2-9/16	9-7/8	9-7/8	6-3/8	8	15/16	15/16	1-11/16	8-1/8	6-1/8	11-9/16	7-11/16	4	3	3-7/16

* Geared units only.
Customer must take into consideration flange width and thickness. Each unit is set for a specified flange width and is not adjustable.
Dimensions shown are accurate for any "S" or "WF" beam.
Flat tread wheels (not shown) supplied for "WF" applications.
Curve radius must always be specified when ordering.
Hoists for wider flange widths than illustrated above may be possible. Consult factory.



CUSTOM-BUILT CHESTER ZEPHYR CLEAN-ROOM. SWIVEL-TRUCK. LOW-HEADROOM TROLLEY HOIST WITH EXTENDED HANDWHEEL IN USE AT A FOOD MANUFACTURING FACILITY.

ZEPHYR TWIN-HOOK HOISTS

CAPACITIES	LIFT	HOOK SPACING	OPTIONS
1/2 to 6 Tons	8 Feet Standard	3 Feet Standard (Up to 16 Feet)	Spark & Corrosion Resistance Clean Room

Chester Zephyr twin-hook hoists are available with hooks up to 16 feet between centers and extra-long lifts as needed. Twin-hook hoists drive two separate load chains simultaneously from a single hand chain and allow operators to more easily and evenly lift long and bulky loads. Twin-hook hoists are well suited to lifting awkward and cumbersome items such as tubes, frames, towers, drying and storage racks, auto and truck bodies, vats and tanks. Suspension hooks can be hung from trolleys or fixed positions.

KEY FEATURES

CHESTER ZEPHYR TWIN-HOOK HOISTS CONTAIN ALL OF THE SAME KEY FEATURES AS THE HOOK-SUSPENDED MODELS.

SPECIFICATIONS

Capacity (tons)	Catalog Number	Standard Lift (ft.)	Chain Pull to Lift Full Load One Foot (lbs.)	Chain Overhauled to Lift Load One Foot (ft.)	Net Weight (lbs.)
REGULAR UNITS					
1/2	133 - 1/2	8	35	33	106
1	133 - 1	8	70	33	162
1-1/2	133 - 1 1/2	8	64	58	287
2	133 - 2	8	83	58	412
3	133 - 3	8	66	116	535
4	133 - 4	8	86	116	592
5	133 - 5	8	71	174	715
6	133 - 6	8	86	174	715
SPARK-RESISTANT UNITS					
1/2	133-1/2SR	8	35	33	106
1	133-1SR	8	70	33	162
1-1/2	133-1-1/2SR	8	64	58	287
2	133-2SR	8	83	58	412
3	133-3SR	8	66	116	535
4	133-4SR	8	86	116	592
5	133-5SR	8	71	174	715
6	133-6SR	8	86	174	715
8	133-8SR	Contact Factory			
10	133-10SR				

Center baring required for shafts over 10 feet. For capacities beyond 6 Ton, contact factory.



1/2 TO 6 TON

DIMENSIONS

Capacity (tons)	Dimensions (in.)								
	A	B (standard)	C	D	E	F	H	I	J
REGULAR UNITS									
1/2	12-1/8	36	7-1/4	4-1/4	4-1/4	3	1-3/8	5-7/8	1
1	12-1/4	36	7-1/4	4-1/4	4-1/4	3	1-3/8	5-7/8	1
1-1/2	15-7/8	36	9-1/4	5	5	3-1/4	1-3/4	8-1/8	1-1/8
2	15-7/8	36	9-3/4	5	5	3-1/4	1-3/4	8-1/8	1-1/8
3	23-1/2	36	9-3/4	5	5	3-1/4	4-7/8	9-1/8	1-11/32
4	24-1/2	36	9-3/4	5	5	3-1/4	4-7/8	9-5/8	1-11/16
5	25-1/2	36	9-3/4	5	5	3-1/4	6-3/8	11-1/2	1-11/16
6	25-1/2	36	9-3/4	5	5	3-1/4	6-3/8	11-1/2	1-11/16
SPARK-RESISTANT UNITS									
1/2	13	36	7-1/4	4-1/4	4-1/4	3	1-3/8	6-7/8	1
1	13	36	7-1/4	4-1/4	4-1/4	3	1-3/8	6-7/8	1
1-1/2	16-7/8	36	9-1/4	5	5	3-1/4	1-3/4	8-1/8	1-13/16
2	16-7/8	36	9-3/4	5	5	3-1/4	1-3/4	8-1/8	1-13/16
3	23-1/8	36	9-3/4	5	5	3-1/4	4-7/8	9-1/8	1-11/16
4	26-1/4	36	9-3/4	5	5	3-1/4	4-7/8	9-13/16	2-7/32
5	26-1/4	36	9-3/4	5	5	3-1/4	6-3/8	10-11/16	2-7/32
6	28-1/4	36	9-3/4	5	5	3-1/4	6-3/8	11-11/16	2-1/4
8	31-13/16							13-7/32	3-1/32
10	34-1/4							14-1/8	3-1/32

Contact Factory

ZEPHYR EXTENDED HANDWHEEL HOISTS

CAPACITIES

1/2 to 6 Tons

LIFT

8 Feet Standard

**EXTENDED
HANDWHEEL**

3 Feet Standard

OPTIONS

Spark & Corrosion Resistance
Clean Room

The extended handwheel model of the Chester Zephyr hoist provides unique benefits in lifting applications. The design allows the operator to stand at a distance from the load for increased safety, if required, and also helps protect work surfaces from scratching or damage from the hand chain. The hoist is also ideal for lifting large flat or bulky loads that may be difficult to lift using a standard hoist. Hoist can be suspended from fixed supports or on a trolley.

KEY FEATURES

CHESTER ZEPHYR HOISTS WITH EXTENDED HANDWHEELS CONTAIN ALL OF THE SAME KEY FEATURES AS THE HOOK-SUSPENDED MODELS.

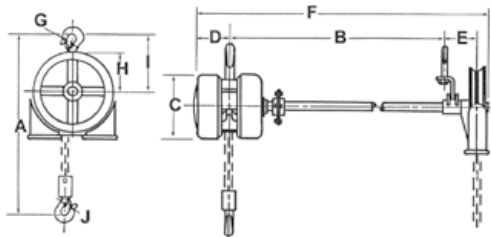

1/2 TO 2 TON



DIMENSIONS

Capacity (tons)	Dimensions (in.)									
	A	B	C	D	E	F	G	H	I	J
REGULAR UNITS										
1/2	12-1/8	29-7/16	7-1/4	4-1/4	6-9/16	41-7/16	1	4-21/32	6-7/16	1
1	12-1/4	29-7/16	7-1/4	4-1/4	6-9/16	41-7/16	1	4-21/32	6-7/16	1
1-1/2	15-7/8	29-1/2	9-3/4	5	6-1/2	42-1/4	1	5-21/32	7-5/8	1-1/8
2	15-7/8	29-1/2	9-3/4	5	6-1/2	42-1/4	1	5-21/32	7-5/8	1-1/8
SPARK-RESISTANT UNITS										
1/2	13	29-7/16	7-1/4	4-1/4	6-9/16	41-7/16	1	4-21/32	6-7/8	1
1	13	29-7/16	7-1/4	4-1/4	6-9/16	41-7/16	1	4-21/32	6-7/8	1
1-1/2	16-7/8	29-1/2	9-3/4	5	6-1/2	42-1/4	1	5-21/32	8-1/8	1-13/32
2	16-7/8	29-1/2	9-3/4	5	6-1/2	42-1/4	1	5-21/32	8-1/8	1-13/32

For capacities beyond 2 Ton, contact factory.



SPECIFICATIONS

Capacity (tons)	Catalog Number	Standard Lift (ft.)	Handwheel Extension		Net Weight (lbs.)
			Standard (ft.)	Maximum (ft.)	
REGULAR UNITS					
1/2	134 - 1/2	8	3	10	78
1	134 - 1	8	3	10	84
1-1/2	134 - 1-1/2	8	3	10	115
2	134 - 2	8	3	10	125
SPARK-RESISTANT UNITS					
1/2	134 - 1/2	8	3	10	80
1	134 - 1	8	3	10	86
1-1/2	134 - 1-1/2	8	3	10	120
2	134 - 2	8	3	10	130

For capacities beyond 2 Ton, contact factory.

HAND-PROPELLED, OVERHEAD I-BEAM PT TROLLEYS

CAPACITIES

1/4 to 50 Tons

**BEAM ADJUSTMENT
RANGE**

2.66 to 8 in.

**MINIMUM
RADIUS CURVE**

20 to 120 in.

OPTIONSSpark & Corrosion Resistance
Clean Room

For easy hoist attachment and ease of movement, Chester offers a wide variety of manually operated plain and geared trolleys. These trolleys feature concentrically machined wheels for easy rolling motion as well as high-quality, anti-friction bearings to assure minimal effort is needed for positioning. All capacities feature heavy rolled steel side plates complete with bumper/drop stops as standard to provide a full face bumper to contact beam end stops.

KEY FEATURES**MINIMUM MANUAL EFFORT & EASY MAINTENANCE**

Lifetime-lubricated precision ball bearings in ¼- to 3-ton capacities reduce manual effort and allow for easy maintenance. In 4- to 25-ton capacities, each trolley is equipped with eight sealed and tapered roller bearings that absorb the radial and thrust loads exerted in these heavier sizes while also allowing for ease of use and maintenance.

STABLE AND RIGID CONSTRUCTION

Heavy rolled-steel side plates are shaped to provide stability and rigidity.

LOAD EQUALIZATION & SMOOTH OPERATION

Steel equalizing pins connect the two halves of each trolley, providing load equalization and smooth operation.

DURABLE, SMOOTH-RUNNING TROLLEY WHEELS

Trolley wheels are long-wearing alloy cast iron. Wheel treads are machined to provide smoothest possible rolling motion. Steel axles are rigidly supported in the side frame. Steel trolley blocks reinforce the side plates as well as the equalizing pin.

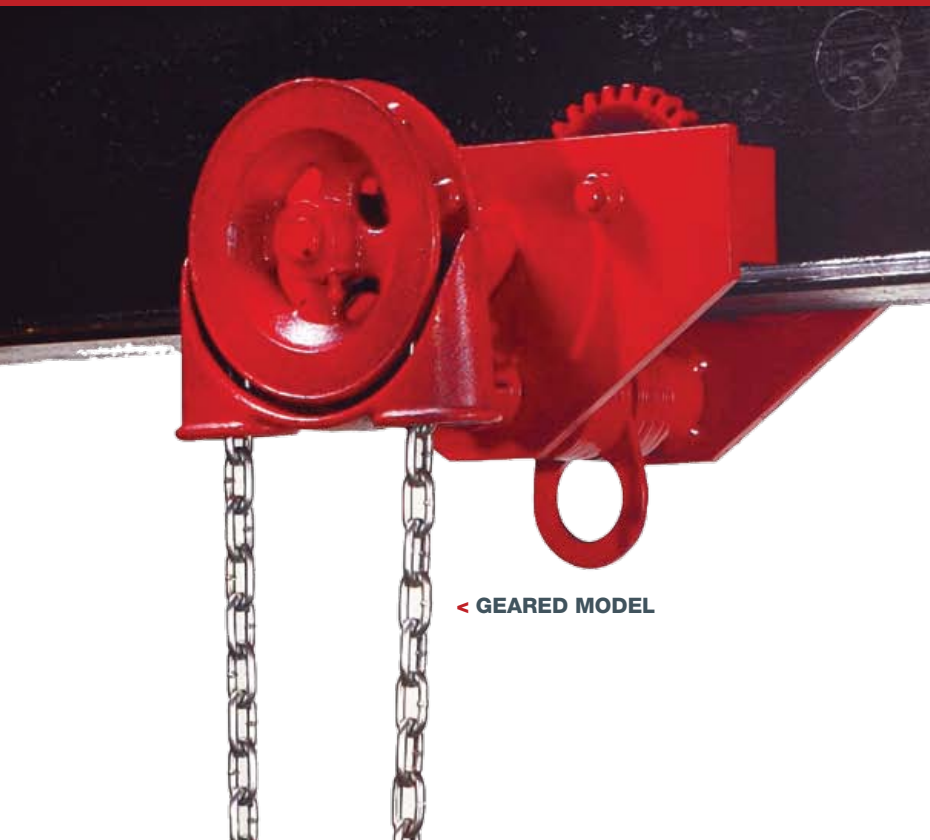

◀ GEARED MODEL

SPARK-RESISTANT OPTIONS

SOLID BRONZE WHEELS

Concentrically machined for smooth rolling motion.

STAINLESS STEEL DROP STOPS

ALUMINUM HAND CHAIN GUARD

**ALUMINUM OR STAINLESS STEEL
HAND CHAIN**

CORROSION-RESISTANT OPTIONS

SPECIAL CORROSION-RESISTANT FINISHES

Created specifically for operation in salt-laden or other corrosive environments.

CLEAN ROOM OPTIONS

FOOD-GRADE EPOXY PAINT

STAINLESS STEEL WHEELS

STAINLESS STEEL BEARINGS

STAINLESS STEEL HAND CHAIN

**COMPLETE STAINLESS STEEL UNITS
AVAILABLE FOR SOME CAPACITIES**

“THE ULTIMATE CLEAN ROOM TROLLEY”



◀ PLAIN MODEL

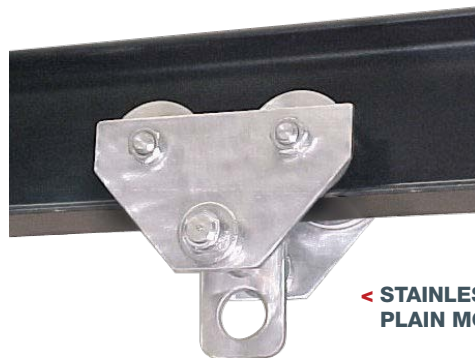

◀ STAINLESS-STEEL
PLAIN MODEL

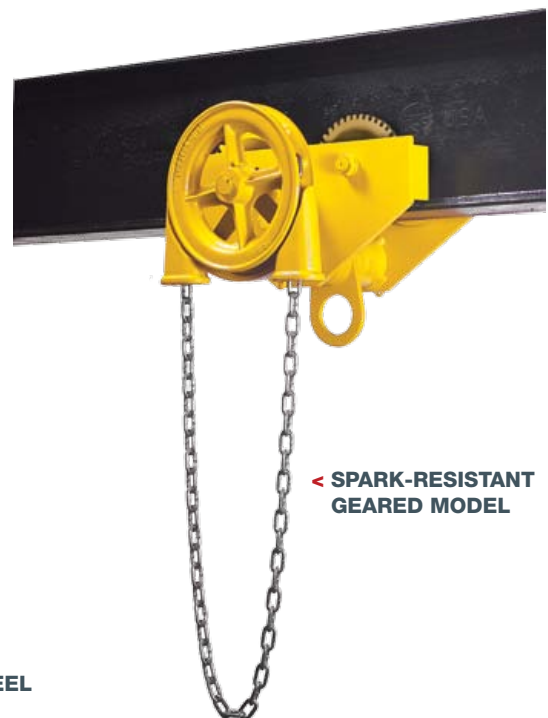

◀ SPARK-RESISTANT
GEARED MODEL

HAND-PROPELLED, OVERHEAD I-BEAM PT TROLLEYS

SPECIFICATIONS

Capacity (tons)	Catalog Number				Beam Adjustment Range (in.) *	Min. Beam Height (in.) **	Hand Chain Reach from Beam (G geared Trolleys) (ft.)	Minimum Radius Curve (in.) ***	Pounds of Push to Move Plain Trolley, Fully Loaded (lbs.)	Net Weight (lbs.)	
	Plain Trolley	Geared Trolley	Spark-Resistant Plain Trolley	Spark-Resistant Geared Trolley						Plain Trolley	Geared Trolley
1/4	1641-0025	–	1641-0025SR	–	2.66 to 5.0	4	8	20	7	23	38
1/2	1641-0050	–	1641-0050SR	–	2.66 to 5.0	4	8	20	14	23	38
1	1641-0100	1642-0100	1641-0100SR	1642-0100SR	3 to 6	5	8	24	18	43	62
1-1/2	1641-0150	1642-0150	1641-0150SR	1642-0150SR	3 to 6	5	8	24	28	45	65
2	1641-0200	1642-0200	1641-0200SR	1642-0200SR	3.33 to 6.25	6	8	30	38	67	90
3	1641-0300	1642-0300	1641-0300SR	1642-0300SR	3.33 to 6.25	6	8	30	44	70	93
4	1641-0400	1642-0400	1641-0400SR	1642-0400SR	4 to 7	8	8	36	59	155	184
5	1641-0500	1642-0500	1641-0500SR	1642-0500SR	4 to 7	8	8	36	61	160	188
6	1641-0600	1642-0600	1641-0600SR	1642-0600SR	4 to 7	8	8	36	73	160	188
8	1641-0800	1642-0800	1641-0800SR	1642-0800SR	4.62 to 8	10	8	60	85	300	347
10	1641-1000	1642-1000	1641-1000SR	1642-1000SR	4.62 to 8	10	8	60	90	310	360
12	1641-1200	1642-1200	1641-1200SR	1642-1200SR	4.62 to 8	10	8	60	110	310	360
16	1641-1600	1642-1600	1641-1600SR	1642-1600SR	6 to 8	12	8	96	120	600	650
20	1641-2000	1642-2000	1641-2000SR	1642-2000SR	6 to 8	12	8	96	156	610	660
25	1631-2500	1632-2500	1631-2500SR	1632-2500SR	6 to 8	18	8	120	195	1045	1200
30	1641-3000	1642-3000	1641-3000SR	1642-3000SR	7 to 8	24	8	–	240	1520	1615
40	1641-4000	1642-4000	1641-4000SR	1642-4000SR	7 to 8	24	8	–	312	1776	1886
50	1631-5000	1632-5000	1631-5000SR	1632-5000SR	7 to 8	24	8	–	390	2676	2831

* NOTE: Consult factory for beams outside of this standard range.

** NOTE: Beam height shown is for proper wheel running clearance only. The customer must verify their chosen beam is adequate for the intended application and loads. Consult factory for beams smaller than the minimum specified.

***NOTE: Minimum radius applies to minimum flange width and may vary with beam. For curve applications consult factory. Curves must be specified when ordering.

1/4 through 20 ton units are supplied straight sided with universal wheels for operation on flat or tapered beams.

For patented track applications consult factory.

25 and 50 ton units are supplied with canted side plates for operation on standard American tapered I-beams.

For other beams consult factory.

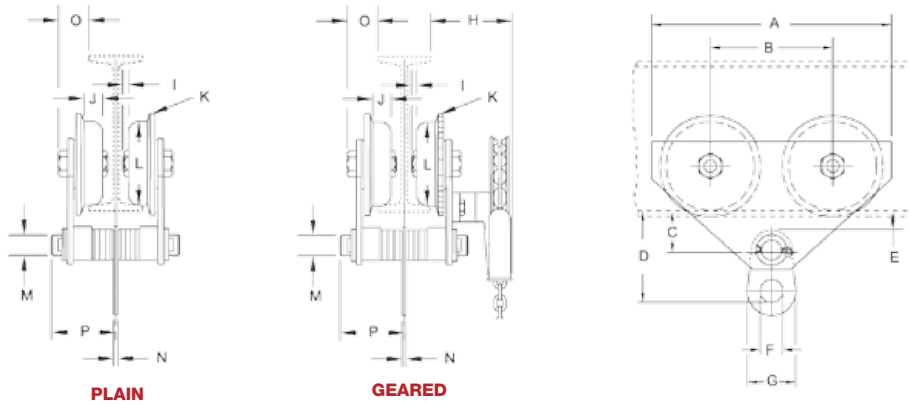

DIMENSIONS

Capacity (tons)	Dimensions (In.)															
	A	B	C	D	E	F	G	H	I	J	K	L	M	N	O	P
PLAIN & GEARED TROLLEY																
1/4	11-1/2	6	1-7/8	4-7/8	7/8	1-3/4	2-3/4	6	0	7/8	4	2-7/8	1	1/4	2	4-1/8
1/2	13-1/4	6-3/4	2-1/4	5-3/8	1	1-3/4	3	6-1/8	0	1-1/8	5	3-3/4	1-1/4	1/4	1-3/4	4-3/4
1	13-1/4	6-3/4	2-1/4	5-5/8	1	2	3-1/4	6-1/8	0	1-1/8	5	3-3/4	1-1/4	3/8	1-3/4	4-3/4
1-1/2	13-1/4	6-3/4	2-1/4	5-5/8	1	2	3-1/4	6-1/8	0	1-1/8	5	3-3/4	1-1/4	3/8	1-3/4	4-3/4
2	15-5/8	7-5/8	2-5/8	6-3/4	1-1/8	2-1/8	3-5/8	6-1/8	0	1-1/8	6	4-1/2	1-1/2	3/8	2-1/8	5-1/4
3	15-5/8	7-5/8	2-5/8	6-7/8	1-1/8	2-1/4	4	6-1/8	0	1-1/8	6	4-1/2	1-1/2	1/2	2-1/8	5-1/4
4	18-3/4	8-1/2	3-1/4	8-3/8	1-1/4	2-3/4	4-3/4	8-1/8	1/8	1-3/8	8	6-3/8	2	5/8	2-5/8	6-1/8
5	18-3/4	8-1/2	3-1/4	8-5/8	1-1/4	3	5-1/2	8-1/8	1/8	1-3/8	8	6-3/8	2	5/8	2-5/8	6-1/8
6	18-3/4	8-1/2	3-1/4	8-5/8	1-1/4	3	5-1/2	8-1/8	1/8	1-3/8	8	6-3/8	2	5/8	2-5/8	6-1/8
8	23-5/8	10-5/8	3-7/8	10-5/8	1-3/8	3-1/2	6-1/2	9	1/8	1-11/16	10	8-1/4	2-1/2	3/4	3-1/4	6-7/8
10	23-5/8	10-5/8	3-7/8	11-1/8	1-3/8	4-1/2	8	9	1/8	1-11/16	10	8-1/4	2-1/2	1	3-1/4	6-7/8
12	23-5/8	10-5/8	3-7/8	11-1/8	1-3/8	4-1/2	8	9	1/8	1-11/16	10	8-1/4	2-1/2	1	3-1/4	6-7/8
16	28	12	4-3/4	13-3/4	1-7/16	4	9	10-11/16	1/4	1-3/4	11-11/16	9-3/4	3-1/4	1-1/4	4-5/8	7-5/8
20	28	12	4-3/4	16-3/4	1-7/16	4-1/2	10	10-11/16	1/4	1-3/4	11-11/16	9-3/4	3-1/4	1-1/4	4-5/8	7-5/8
25	28-1/4	14	5-7/8	16-3/4	2-1/8	4	10	14-1/2	5/16	2	13-1/2	11-3/4	3-1/4	1-3/4	7	8-1/4
30	Consult Factory															
40	Consult Factory															
50	Consult Factory															
PLAIN & GEARED TROLLEY, SPARK-RESISTANT																
1/4	11-1/2	6	1-7/8	4-7/8	7/8	1-3/4	2-3/4	6	0	7/8	4	2-7/8	1	1/4	2	4-1/8
1/2	13-1/4	6-3/4	2-1/4	5-3/8	1	1-3/4	3	6-1/8	0	1-1/8	5	3-3/4	1-1/4	1/4	1-3/4	4-3/4
1	13-1/4	6-3/4	2-1/4	5-5/8	1	2	3-1/4	6-1/8	0	1-1/8	5	3-3/4	1-1/4	3/8	1-3/4	4-3/4
1-1/2	13-1/4	6-3/4	2-1/4	5-5/8	1	2	3-1/4	6-1/8	0	1-1/8	5	3-3/4	1-1/4	3/8	1-3/4	4-3/4
2	15-5/8	7-5/8	2-5/8	6-3/4	1-1/8	2-1/8	3-5/8	6-1/8	0	1-1/8	6	4-1/2	1-1/2	3/8	2-1/8	5-1/4
3	15-5/8	7-5/8	2-5/8	6-7/8	1-1/8	2-1/4	4	6-1/8	0	1-1/8	6	4-1/2	1-1/2	1/2	2-1/8	5-1/4
4	18-3/4	8-1/2	3-1/4	8-3/8	1-1/4	2-3/4	4-3/4	8-1/8	1/8	1-3/8	8	6-3/8	2	5/8	2-5/8	6-1/8
5	18-3/4	8-1/2	3-1/4	8-5/8	1-1/4	3	5-1/2	8-1/8	1/8	1-3/8	8	6-3/8	2	5/8	2-5/8	6-1/8
6	18-3/4	8-1/2	3-1/4	8-5/8	1-1/4	3	5-1/2	8-1/8	1/8	1-3/8	8	6-3/8	2	5/8	2-5/8	6-1/8
8	23-5/8	10-5/8	3-7/8	10-5/8	1-3/8	3-1/2	6-1/2	9	1/8	1-11/16	10	8-1/4	2-1/2	3/4	3-1/4	6-7/8
10	23-5/8	10-5/8	3-7/8	11-1/8	1-3/8	4-1/2	8	9	1/8	1-11/16	10	8-1/4	2-1/2	1	3-1/4	6-7/8
12	23-5/8	10-5/8	3-7/8	11-1/8	1-3/8	4-1/2	8	9	1/8	1-11/16	10	8-1/4	2-1/2	1	3-1/4	6-7/8
16	28	12	4-3/4	13-3/4	1-7/16	4	9	10-11/16	1/4	1-3/4	11-11/16	9-3/4	3-1/4	1-1/4	4-5/8	7-5/8
20	28	12	4-3/4	16-3/4	1-7/16	4-1/2	10	10-11/16	1/4	1-3/4	11-11/16	9-3/4	3-1/4	1-1/4	4-5/8	7-5/8
25	28-1/4	14	5-7/8	16-3/4	2-1/8	4	10	14-1/2	5/16	2	13-1/2	11-3/4	3-1/4	1-3/4	7	8-1/4
30	Consult Factory															
40	Consult Factory															
50	Consult Factory															

NOTE: To better illustrate wheels, bumpers have been omitted from the drawings on this page. Wheels with convex treads are standard on all capacities 1/4 ton through 20 ton. 30, 40 & 50 ton trolleys are available furnished in tandem construction. Consult factory for dimensions. Dimensions vary proportionately with beam size.

HAND-PROPELLED, OVERHEAD ADJUSTABLE **SWIVEL-TRUCK TROLLEYS**

CAPACITIES

1/4 to 6 Tons

**BEAM ADJUSTMENT
RANGE**

2-5/8 to 8 in.

**MINIMUM
RADIUS CURVE**

9-7/8 to 33-7/8 in.

OPTIONSSpark & Corrosion Resistance
Wide Flange or Patented Track
Clean Room

Chester swivel-truck trolleys are the ideal choice when your application requires a trolley that can traverse the tightest curves with ease while maintaining an absolute minimum distance between the runway beam and load eye. The forged steel load eye on these swivel-truck trolleys is suspended on a special load bar carried at each end by a swiveling two-wheeled trolley unit. Design allows for easy attachment of hook-suspended Chester Zephyr hoists.

KEY FEATURES**MINIMUM MANUAL EFFORT & EASY MAINTENANCE**

Lifetime-lubricated precision ball bearings in ¼- to 2-ton capacities reduce manual effort and allow for easy maintenance. 3- to 6-ton capacity trolleys are equipped with eight sealed and tapered roller bearings that also reduce effort and promote easy maintenance.

DURABLE, SMOOTH-RUNNING TROLLEY WHEELS

Trolley wheels are cast iron and through hardened for long life. Wheel treads are concentrically machined to provide smoothest possible rolling motion.

OPTIONS & CONFIGURATIONS

Trolleys may be special ordered for operation on wide flange beams or patented track. A trolley track lock, trolley bumpers and anti-drop lugs can also be ordered with these units.

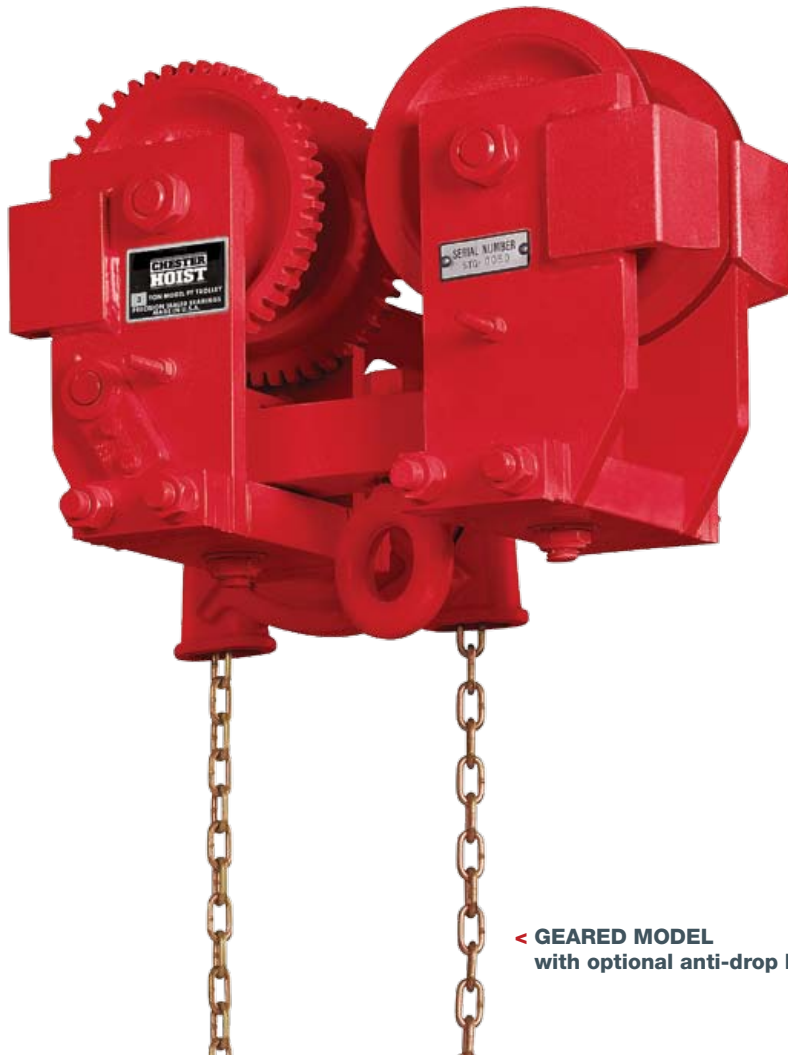

◀ **GEARED MODEL**
with optional anti-drop lugs

SPARK-RESISTANT OPTIONS

SOLID BRONZE WHEELS

Concentrically machined for smooth rolling motion.

STAINLESS STEEL DROP STOPS

ALUMINUM HAND CHAIN GUARD

**ALUMINUM OR STAINLESS STEEL
HAND CHAIN**

CORROSION-RESISTANT OPTIONS

SPECIAL CORROSION-RESISTANT FINISHES

Created specifically for operation in salt-laden or other corrosive environments.

CLEAN ROOM OPTIONS

FOOD-GRADE EPOXY PAINT

STAINLESS STEEL WHEELS

STAINLESS STEEL BEARINGS

STAINLESS STEEL HAND CHAIN



◀ **SPARK-RESISTANT GEARED MODEL**
with optional anti-drop lugs

HAND-PROPELLED, OVERHEAD ADJUSTABLE SWIVEL-TRUCK TROLLEYS

SPECIFICATIONS

Capacity (tons)	Catalog Number		Beam Adjustment Range (in.) *	Minimum Beam Height (in.) **	Hand Chain Reach from Beam (Geared Trolleys) (ft.)	Minimum Radius Curve (in.) ***	Pounds of Push to Move Plain Trolley, Fully Loaded (lbs.)	Net Weight (lbs.)	
	Plain Trolley	Geared Trolley						Plain Trolley	Geared Trolley
1/4	1831-1/4	1832-1/4	2-5/8 to 4-5/8	4	8	9-7/8	7	45	63
1/2	1831-1/2	1832-1/2	2-5/8 to 4-5/8	4	8	9-7/8	14	45	63
1	1831-1	1832-1	3 to 4-5/8	5	8	9-7/8	18	58	75
1-1/2	1831-1-1/2	1832-1-1/2	3-5/8 to 5-1/2	6	8	19-1/2	28	83	105
2	1831-2	1832-2	3-5/8 to 5-1/2	6	8	19-1/2	38	83	105
3	1831-3	1832-3	4 to 7	8	8	15-3/8	44	155	185
4	1831-4	1832-4	4 to 7	8	8	15-3/8	59	155	185
5	1831-5	1832-5	4-5/8 to 8	10	8	33-7/8	61	274	303
6	1831-6	1832-6	4-5/8 to 8	10	8	33-7/8	73	274	303

* NOTE: Consult factory for beams outside of this standard range.

** NOTE: Beam height shown is for proper wheel running clearance only. The customer must verify their chosen beam is adequate for the intended application and loads. Consult factory for beams smaller than the minimum specified.

***NOTE: Minimum radius applies to minimum flange width and may vary with beam.

For curve applications consult factory.

Curves must be specified when ordering.

Convex tread wheels are standard for standard I-beams for all capacities. Trolleys operating on patented track or wide flange beams will have flat tread wheels. Patented track and wide flange beam applications must be specified.

For patented track applications consult factory.

For other beams consult factory.

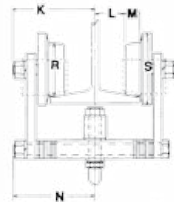
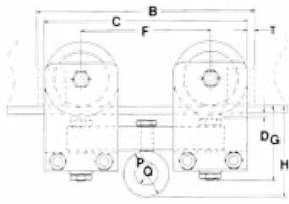

PLAIN
Units shown with optional bumpers

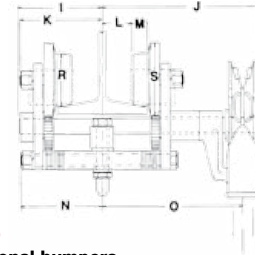
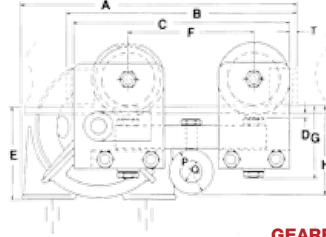

GEARED
Units shown with optional bumpers

DIMENSIONS

Capacity (tons)	Dimensions (In.)																			
	A	B	C	D**	E	F	G	H	I	J	K*	L*	M	N	O	P	Q	R	S	T
PLAIN TROLLEY																				
1/4	-	11-3/4	11	5/16	-	7	4-1/16	4-7/8	-	-	4-1/2	1-9/16	7/8	4-5/16	-	2-1/2	1-1/4	2-7/8	3-5/8	3/8
1/2	-	11-3/4	11	5/16	-	7	4-1/16	4-7/8	-	-	4-1/2	1-9/16	7/8	4-5/16	-	2-1/2	1-1/4	2-7/8	3-5/8	3/8
1	-	13	12	5/16	-	7	4-3/8	5-1/8	-	-	4-3/4	1-1/4	1-3/32	4-3/8	-	2-1/2	1-1/4	3-3/4	5	1
1-1/2	-	16-1/4	14-1/4	1/4	-	8-1/4	4-1/2	5-1/2	-	-	5	1-3/4	1-1/8	5	-	3	1-1/2	4-1/2	6	1
2	-	16-1/4	14-1/4	1/4	-	8-1/4	4-1/2	5-1/2	-	-	5	1-3/4	1-1/8	5	-	3	1-1/2	4-1/2	6	1
3	-	18-3/4	17-1/2	1/4	-	9-1/2	6-1/2	8-1/32	-	-	6	2-1/16	1-11/32	6	-	3-3/4	2	6-3/8	8	1-1/8
4	-	18-3/4	17-1/2	1/4	-	9-1/2	6-1/2	8-1/32	-	-	6	2-1/16	1-11/32	6	-	3-3/4	2	6-3/8	8	1-1/8
5	-	22-3/4	20-3/4	3/16	-	11-3/4	7-5/8	10-3/8	-	-	7-5/8	2-11/16	1-7/16	7-1/2	-	5-1/2	3	7-3/16	9	2-1/4
6	-	22-3/4	20-3/4	3/16	-	11-3/4	7-5/8	10-3/8	-	-	7-5/8	2-11/16	1-7/16	7-1/2	-	5-1/2	3	7-3/16	9	2-1/4
GEARED TROLLEY																				
1/4	15-3/8	12-3/4	12	1/4	5-1/8	7	4-1/16	4-7/8	4-7/19	9-1/8	4-1/2	1-9/16	7/8	4-5/16	7-7/8	2-1/2	1-1/4	2-7/8	4	3/8
1/2	15-3/8	12-3/4	12	1/4	5-1/8	7	4-1/16	4-7/8	4-7/19	9-1/8	4-1/2	1-9/16	7/8	4-5/16	7-7/8	2-1/2	1-1/4	2-7/8	4	3/8
1	15-13/16	13-1/2	12-7/8	5/16	5-5/16	7	4-3/8	5-1/8	4-7/16	9-1/8	4-3/4	1-1/4	1-3/32	4-3/8	7-7/8	2-1/2	1-1/4	3-3/4	5	1
1-1/2	17-3/4	16-1/4	14-1/4	1/4	5-7/16	8-1/4	4-1/2	5-1/2	4-13/16	8-3/4	5	1-3/4	1-1/8	5	7-7/8	3	1-1/2	4-1/2	6	1
2	17-3/4	16-1/4	14-1/4	1/4	5-7/16	8-1/4	4-1/2	5-1/2	4-13/16	8-3/4	5	1-3/4	1-1/8	5	7-7/8	3	1-1/2	4-1/2	6	1
3	20-1/4	18-3/4	17-1/2	1/4	6-5/8	9-1/2	6-1/2	8-1/32	5-7/8	9-3/4	6	2-1/16	1-11/32	6	8-1/2	3-3/4	2	6-3/8	8	1-1/8
4	20-1/4	18-3/4	17-1/2	1/4	6-5/8	9-1/2	6-1/2	8-1/32	5-7/8	9-3/4	6	2-1/16	1-11/32	6	8-1/2	3-3/4	2	6-3/8	8	1-1/8
5	25-9/16	22-1/4	20-3/4	1/4	8-7/16	11-3/4	7-5/8	10-3/8	6-13/16	11-5/16	7-5/8	2-11/16	1-7/16	7-1/2	10	5-1/2	3	7-3/16	9	2-1/4
6	25-9/16	22-1/4	20-3/4	1/4	8-7/16	11-3/4	7-5/8	10-3/8	6-13/16	11-5/16	7-5/8	2-11/16	1-7/16	7-1/2	10	5-1/2	3	7-3/16	9	2-1/4
PLAIN TROLLEY, SPARK-RESISTANT																				
1/4	-	11-3/4	11	5/16	-	7	4-1/16	4-7/8	-	-	4-1/2	1-9/16	7/8	4-5/16	-	2-1/2	1-1/4	2-7/8	3-5/8	3/8
1/2	-	11-3/4	11	5/16	-	7	4-1/16	4-7/8	-	-	4-1/2	1-9/16	7/8	4-5/16	-	2-1/2	1-1/4	2-7/8	3-5/8	3/8
1	-	13	12	5/16	-	7	4-3/8	5-1/8	-	-	4-3/4	1-1/4	1-3/32	4-3/8	-	2-1/2	1-1/4	3-3/4	5	1
1-1/2	-	16-1/4	14-1/4	1/4	-	8-1/4	4-1/2	5-1/2	-	-	5	1-3/4	1-1/8	5	-	3	1-1/2	4-1/2	6	1
2	-	16-1/4	14-1/4	1/4	-	8-1/4	4-1/2	5-1/2	-	-	5	1-3/4	1-1/8	5	-	3	1-1/2	4-1/2	6	1
3	-	18-3/4	17-1/2	1/4	-	9-1/2	6-1/2	8-1/32	-	-	6	2-1/16	1-11/32	6	-	3-3/4	2	6-3/8	8	1-1/8
4	-	18-3/4	17-1/2	1/4	-	9-1/2	6-1/2	8-1/32	-	-	6	2-1/16	1-11/32	6	-	3-3/4	2	6-3/8	8	1-1/8
5	-	22-3/4	20-3/4	3/16	-	11-3/4	7-5/8	10-3/8	-	-	7-5/8	2-11/16	1-7/16	7-1/2	-	5-1/2	3	7-3/16	9	2-1/4
6	-	22-3/4	20-3/4	3/16	-	11-3/4	7-5/8	10-3/8	-	-	7-5/8	2-11/16	1-7/16	7-1/2	-	5-1/2	3	7-3/16	9	2-1/4
GEARED TROLLEY, SPARK-RESISTANT																				
1/4	15-3/8	12-3/4	12	1/4	5-1/8	7	4-1/16	4-7/8	4-7/19	9-1/8	4-1/2	1-9/16	7/8	4-5/16	7-7/8	2-1/2	1-1/4	2-7/8	4	3/8
1/2	15-3/8	12-3/4	12	1/4	5-1/8	7	4-1/16	4-7/8	4-7/19	9-1/8	4-1/2	1-9/16	7/8	4-5/16	7-7/8	2-1/2	1-1/4	2-7/8	4	3/8
1	15-13/16	13-1/2	12-7/8	5/16	5-5/16	7	4-3/8	5-1/8	4-7/16	9-1/8	4-3/4	1-1/4	1-3/32	4-3/8	7-7/8	2-1/2	1-1/4	3-3/4	5	1
1-1/2	17-3/4	16-1/4	14-1/4	1/4	5-7/16	8-1/4	4-1/2	5-1/2	4-13/16	8-3/4	5	1-3/4	1-1/8	5	7-7/8	3	1-1/2	4-1/2	6	1
2	17-3/4	16-1/4	14-1/4	1/4	5-7/16	8-1/4	4-1/2	5-1/2	4-13/16	8-3/4	5	1-3/4	1-1/8	5	7-7/8	3	1-1/2	4-1/2	6	1
3	20-1/4	18-3/4	17-1/2	1/4	6-5/8	9-1/2	6-1/2	8-1/32	5-7/8	9-3/4	6	2-1/16	1-11/32	6	8-1/2	3-3/4	2	6-3/8	8	1-1/8
4	20-1/4	18-3/4	17-1/2	1/4	6-5/8	9-1/2	6-1/2	8-1/32	5-7/8	9-3/4	6	2-1/16	1-11/32	6	8-1/2	3-3/4	2	6-3/8	8	1-1/8
5	25-9/16	22-1/4	20-3/4	1/4	8-7/16	11-3/4	7-5/8	10-3/8	6-13/16	11-5/16	7-5/8	2-11/16	1-7/16	7-1/2	10	5-1/2	3	7-3/16	9	2-1/4
6	25-9/16	22-1/4	20-3/4	1/4	8-7/16	11-3/4	7-5/8	10-3/8	6-13/16	11-5/16	7-5/8	2-11/16	1-7/16	7-1/2	10	5-1/2	3	7-3/16	9	2-1/4

NOTE: Dimensions based on standard beams at maximum flange width.
 * Dimension will vary with beam size
 ** Minimum under-the-beam clearance not necessarily at point indicated. Dimension will also vary with beam size

ZEPHYR ACCESSORIES

Standard and custom accessories are available for most Chester Zephyr hoist and trolley models. When accessories other than those shown in this catalog are required, contact your Columbus McKinnon sales representative.

TROLLEY TRACK LOCKS

Quick-acting trolley track locks can be supplied with any Chester Model PT trolley or Zephyr trolley hoist. Locks are available as trailer type or built into the trolley. Lever operation, or chain actuated as shown, is optional. Chester track lock jaws are made of steel and grooved to bite and hold firmly to the flange of the runway beam. Jaws will hold with a fully loaded trolley (up to 1,500 lb. in-line pull). Lock is designed to prevent additional load pressures from being applied to the trolley wheels when lock is actuated. Track clamps are available with optional stainless steel jaws and hand chain for spark-resistant applications.



OVERLOAD LIMITERS

Overload limiters are available as an option on all Chester Zephyr hand chain hoists. This “slip clutch” device will allow the hoist to lift its rated load, but is designed to prohibit lifting an overload that could cause damage to the hoist. Overload limiters do not increase the envelope dimensions of the hoist.

CHAIN CONTAINERS

Chain containers are designed to receive idle load chain as it reeves over the load sheave when lifting a load. This prevents the idle chain from interfering or marring and scratching the load or surrounding surfaces. Compact design helps maintain best possible headroom. Containers are available for most Chester hoist models.



BULK HAND CHAIN

Bulk hand chain is available in zinc-plated steel, aluminum and stainless steel to suit nearly any application. This chain can be purchased by the lineal foot and is also available in barrel lengths, providing considerable cost savings versus standard per-foot pricing.

SWINGING HAND WHEEL GUARDS

Used in conjunction with a hand wheel, swinging hand wheel guards help keep the chain seated in the pocketed hand wheel, but also pivots freely on the hand wheel shaft to allow the hand chain to move freely. Guards are available in cast iron or aluminum. Cast iron guards can be supplied with copper plating or electro-less nickel plating for special applications.

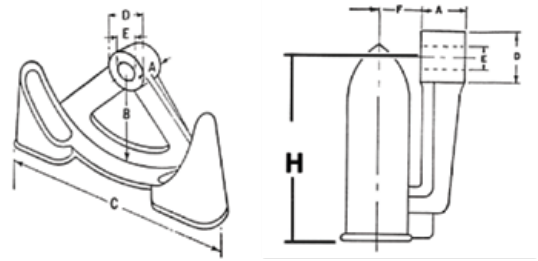

DIMENSIONS

Catalog Number	Dimensions (in.)							Net Weight (lbs.)
	A	B	C	D	E Standard Bore*	F	H	
REGULAR UNITS								
C-37175 (7 PG)	1	2-3/4	5-11/16	1-1/2	7/8	11/16	3-3/8	1-1/2
C-9121-0075 (8 PG)	1-1/4	3-3/4	8-3/4	2	7/8	1-1/8	4-1/16	3-1/2
C-9121-0100 (12 PG)	1-3/8	4-7/8	11-1/8	1- 13/16	7/8 & 1-1/4	13/16	5-3/8	5
C-9121-0150 (15 PG)	1-3/4	4-15/16	13-1/2	2-1/4	7/8 & 1-1/4	1	6-7/8	7
C-9121-1000 (20 PG)	1-3/4	7-3/8	17-1/16	2-1/4	1-1/4	1	8-1/8	11
C-9121-2500 (25 PG)	1-3/4	9	21-3/8	2-3/4	1-1/4 & 1-3/8	1	9-15/16	13

* Special dimensions can be furnished.

POCKETED HAND WHEELS

Pocketed hand wheels are designed for use with the same hand chains used on our Zephyr hand hoists. Hand chain wheels are made of durable ductile cast iron and are available in a variety of finishes, including zinc plating, nickel plating and oil-based enamel or epoxy paint.

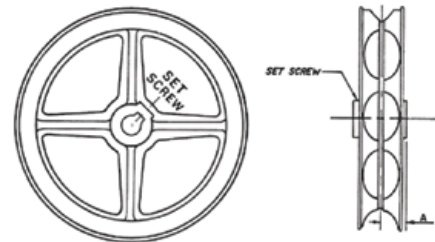

DIMENSIONS

Catalog Number	Dimensions (in.)									Net Weight (lbs.)
	Chain Size	Pitch Diameter	Outside Diameter	Regular Bore *	Max. Bore *	Regular Keyway	Length through Hub	Hub Diameter	A**	
REGULAR UNITS										
C-36072 (7 P)	5MM	4-1/16	5	7/8	1	1/4 x 1/8	1-7/32	1-3/4	39/64	3-1/4
C-9120-0075 (8 P)	1/4	5-1/4	7	7/8	1-1/4	1/4 x 1/8	1-7/8	1-11/16	1	4-1/2
C-9120-0100 (12 P)	1/4	8-1/4	9-5/16	7/8 & 1-1/4	1-1/4	1/4 x 1/8	1-29/32	1-3/4	3/4	9
C-9120-0150 (15 P)	1/4	10	11-5/16	7/8 & 1-1/4	1-3/4	1/4 x 1/8	1-7/8	2-3/8	15/16	12
C-9120-1000 (20 P)	1/4	13-3/8	14-3/8	1-1/4	1-3/4	5/16 x 5/32	1-7/8	2-3/8	15/16	22
C-9120-2500 (25 P)	1/4	16-5/8	17-3/4	1-1/4 & 1-3/8	2	5/16 x 5/32	2-3/4	2-3/4	15/16	32

* Non-Standard bore available. Contact Factory.

** Center-line of hand chain to back.

SPECIAL APPLICATIONS **OIL & GAS PRODUCTS**

The Chester Hoist Company is a long-standing industry leader in providing solutions for the most demanding hoisting requirements of the oil and gas industry. Not only do we offer an unduplicated range of products and distribution for oil and gas applications, we also possess unique experience, knowledge and application engineering capabilities that no other manufacturer can claim. Our network of experienced distributors are located around the world, serving most of the major oil and gas producers and refiners in all major markets.

To address the needs of the oil and gas industry, the Chester Zephyr family of hoists is available with a variety of options, including:

- **LOW HEADROOM**
- **SPARK RESISTANCE**
- **CORROSION RESISTANCE**

For applications in oil and gas environments, Chester Hoist recommends the use of solid spark- and corrosion-resistant materials. Our standard spark-resistant components include stainless steel load chain, wire rope and hook latches as well as solid bronze hooks, hook blocks and trolley wheels with aluminum or stainless steel hand chains. We also provide a wide range of plated chains, hooks and wheels. While many of our competitors also offer plated components, these superficial coatings only offer temporary protection against sparking and corrosion.

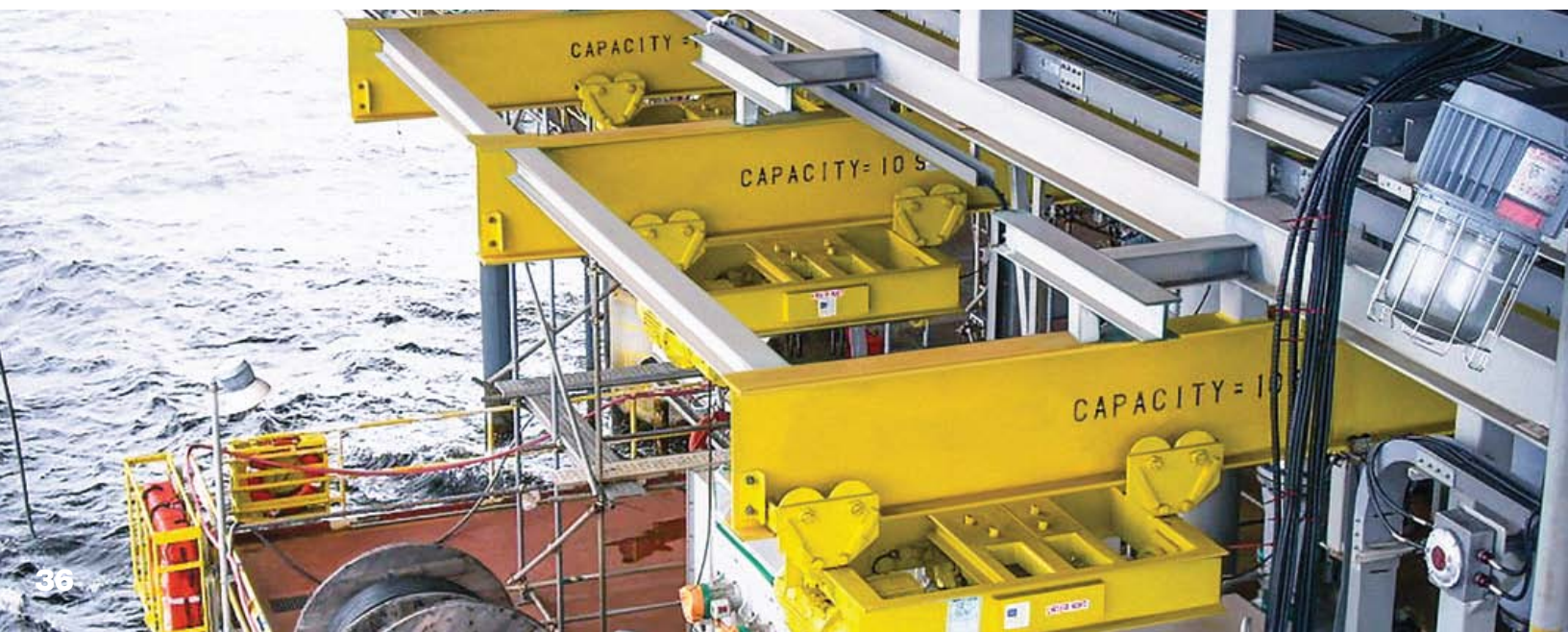

SPECIAL APPLICATIONS

CLEAN ROOM APPLICATIONS

Clean room environments exist in a variety of industries ranging from food processing and pharmaceuticals to electronics and biotechnology. In these environments, even the smallest particle or contaminant could adversely affect the manufacturing process, therefore equipment must meet certain standards and requirements that vary from industry to industry.

The Zephyr can be specially designed to help you meet these standards. The options we offer for our Zephyr hoists can reduce or eliminate the risk of contamination from factors such as corrosion, lubricants or flaking paint. Optional features include:

- STAINLESS STEEL LOAD CHAIN
- STAINLESS STEEL HAND CHAIN
- STAINLESS STEEL HAND CHAIN WHEELS
- STAINLESS STEEL LIFT WHEELS
- STAINLESS STEEL HOOKS
- STAINLESS STEEL LATCHES
- STAINLESS STEEL HOOK BLOCKS
- STAINLESS STEEL HOUSINGS
- GREASE-TIGHT ENCLOSURES WITH FOOD-GRADE LUBRICANTS
- FOOD-GRADE EPOXY FINISH

No matter the clean room environment, Chester has the hoists and trolleys to meet the needs of your application.



In addition to the Chester Zephyr, Chester Hoist manufactures a wide range of hoists, trolleys and crane components to meet all of your material handling challenges. Similar to the Zephyr, these products are available in a wide range of capacities and configurations and are available with several options, including spark resistance, clean-room features and corrosion resistance. Many of Chester's wire rope hoists, electric chain hoists and tractors can be equipped for air operation as well. The majority of Chester products are made here in the USA. Contact our product experts with your specific requirements.

MANUAL HOISTS



MODEL AM MANUAL CHAIN HOISTS

CAPACITIES: 1/4 TO 5 METRIC TONS

LIFTS: 10 FEET STANDARD (UP TO 30 FEET)

Chester Model AM manual chain hoists are designed to be cost efficient, lightweight, portable and versatile. With durable steel frames, steel covers and heat-treated, load-bearing components, the AM hoist is ideal for standard industrial duty or standby maintenance.

Chester's Model AM army-type hoist provides an ideal combination of lightweight construction and versatility in an economically priced army-type manual chain hoist. With capacities from 1/4 to 5 tons, the beam-mounted AM trolley hoist is compact and built to last under a variety of standard industrial and maintenance-duty applications. With Chester's legendary designed-in strength, reliability and durability, each model AM hoist is made in America and designed and tested to meet ANSI B30.16 requirements.

Units are available for all types of beams, including patented tracks and wide flange beams.



FEATURES AND BENEFITS:

- Metric rating with 4:1 design factor
- Steel gear and hand wheel covers for impact resistance and durability
- Alloy steel hoist load chain that is heat treated for strength and endurance
- Forged steel hooks and fully machined cast iron trolley wheels with precision ball bearings
- Simple assembly and maintenance
- Excellent headroom and efficiency

ADDITIONAL OPTIONS & ACCESSORIES:

- Chain containers
- Drop stop/bumpers
- Zinc-plated chains
- Special finishes

ELECTRIC CHAIN HOISTS



MODEL SEL ELECTRIC CHAIN HOISTS

CAPACITIES: 1 TO 25 TONS

LIFTS: 10 FEET STANDARD

OPTIONS: SPARK & CORROSION RESISTANCE, CLEAN ROOM

Chester electric low-headroom chain hoists are designed for applications where headroom is limited. Engineered around proven designs, these hoists provide smooth, quiet, trouble-free operation in a variety of Class III applications.

These low-headroom hoists come equipped with worm drive gear reducers, case-hardened load chain and are available in capacities from 1 to 25 tons. Choose from lug-mounted, push/pull, hand geared or motorized trolley drives, depending on your needs.

Chester electric low-headroom chain hoists can be easily customized to meet the end users' specific needs. Units can be supplied to fit a variety of beams, including I-beams, wide flange beams and patented track, with each unit being custom built for the beam specified on the order.

FEATURES AND BENEFITS:

- 5- or 6-pocket load wheels
- Durable self-locking worm drive transmissions
- Sturdy steel construction
- Direct-acting motor brakes and two precision bearings per trolley wheel
- Standard controls include reversing contactors, 115V control transformers and terminal blocks in a Nema 12 enclosure
- Redundant paddle-type and geared limit switches for both upper and lower hook travel
- Standard voltage of 230/460 Volt, 3 phase

ADDITIONAL OPTIONS & ACCESSORIES:

- Special control enclosures and motors for hazardous environments, including explosion-proof applications
- Application-specific trolleys, including push/pull, hand geared or motorized
- Specially designed push button pendants and control circuits (Common control circuit options include non-standard voltages, fuses, TOLs, current load limiters, trolley soft starts, two-speed or variable-speed operation, inching circuits, encoders and additional limit switches for hoist and trolley travel.)
- Special finishes, including plating and corrosion-resistant paints

PNEUMATIC CHAIN HOISTS



MODEL ALH PNEUMATIC CHAIN HOISTS

CAPACITIES: 1 TO 24 TONS

LIFTS: 10 FEET STANDARD

OPTIONS: SPARK & CORROSION RESISTANCE, CLEAN ROOM

Chester ALH air chain hoists feature a compact, ultra-low headroom design, allowing them to operate in areas where most hoists will not fit. Its steel construction makes it strong and durable, making the hoist suitable for harsh environments. Limit switches and pilot air controls permit safe, variable speed hoisting and trolley movement. Trolleys are available in plain, hand-gearred or motor-driven configurations and feature anti-tilt rollers.

The unique design of the Chester ALH allows it to be easily installed on virtually any closed-end monorail beam.

ADDITIONAL OPTIONS & ACCESSORIES:

- Swivel trolleys for curved monorails
- E-stop on control pendants
- Chain containers
- Rubber trolley bumpers
- Anti-drop lugs

ELECTRIC WIRE ROPE HOISTS



MODEL WD WORM DRIVE WIRE ROPE HOISTS

CAPACITIES: 1/2 TO 15 TONS

LIFTS: UP TO 120 FEET

OPTIONS: SPARK & CORROSION RESISTANCE, CLEAN ROOM

Chester wire rope electric hoists feature worm gear drives for quiet, smooth and reliable operation. Available in capacities ranging from 1 to 15 tons in a variety of configurations, so you can choose the best hoist for your application. Choose from single-hook, twin-hook or multiple-hook models designed for lug, floor, ceiling or trolley mounting.



Low-headroom models are available in capacities ranging from 1 to 7-1/2 tons and are specifically designed for applications requiring minimal hook-to-beam clearance. Low-headroom hoists are available with a lug-mounted, plain trolley, hand-gear trolley or motorized trolley suspension.

Floor- and ceiling-mounted worm drive hoists are used from a stationary position, such as over a hatchway, a loading dock or in an auditorium. Single twin-hook or multiple-hook models with hook spacing up to 40 feet are also available.

Chester trolley-suspended, twin-hook wire rope hoists are designed with dual hooks for special handling applications that require two-point support. Available with push/pull, hand-gear trolley or motorized trolley suspension, these hoists are ideal for lifting and transporting long loads or rolls.

Chester wire rope hoists can be adapted and customized to a variety of applications.

ADDITIONAL OPTIONS & ACCESSORIES:

- Special mounting
- Special controls
- Long lifts
- Pneumatic units available for some models
- Special trolleys

POWERED TRACTOR DRIVES



MODEL TD POWERED TRACTOR DRIVE

CAPACITIES: 1 TO 5 TONS STANDARD

SPEEDS: VARIOUS

LIFTS: VARIOUS

Chester tractor drives offer motorized travel to improve productivity when using push-type underhung crane bridges or push-type monorail hoists. Designed for capacities up to 5 tons, Chester tractor drives are easy to install without removing or disturbing existing equipment.

For underhung crane bridges, the tractor is designed to accommodate any make of crane on various tracks. Twin tractor units can be used to convert push-type cranes to a motorized drive. To do this, the twin tractor drives are wired into a single control panel located on one of the tractors to provide simultaneous operation.

For monorail trolley suspended hoists, a single, powerful motorized tractor provides fast horizontal travel while minimizing worker fatigue. A squirrel cage electric motor and heavy-duty worm gear reducer drives a urethane drive wheel that engages the underside of the track, providing positive travel.

Units are available for a variety of capacities, speeds and runway beams. Choose from standard controls for single or dual operation, without controls or with customized controls.

ADDITIONAL OPTIONS & ACCESSORIES:

- Two speed
- Motor brakes
- Variable speed
- Various voltages and control options
- Soft starts
- Pneumatic units available for some models



CHESTER
CHESTER HOIST, LISBON, OHIO
ZEPHYR
ALL STEEL
5 TON

5
TONS

ASK US ABOUT YOUR SPECIAL REQUIREMENTS

In addition to the large selection of basic Zephyr hoists and trolleys in this catalog, Chester prides itself on its ability to specially engineer products to meet the most exacting customer requirements. Our hoists and trolleys are available with numerous variations and adaptations for unique and specialized applications.

If you have a specific requirement or need a product with specialized features, contact us. We have the experience and breadth of product needed to design and build the exact hoist or trolley you require. The Zephyr line, in particular, can be engineered for exacting clearances and to operate on tight radius curves as well as on switches, turntables and interlocks. We can also customize hoists to operate on narrow-flanged patented monorail track and extra-wide track where wide flange sections are used.

Spark-resistant bronze or stainless steel parts can also be supplied, along with other options such as chain containers or buckets, track clamps, hand wheel extensions or twin-hook features.

Call us today and let us show you what we can do. We can engineer a product to meet your most demanding requirements.



BUY WITH CONFIDENCE

Chester Hoist is proud to be compliant with the "Buy American Act".

We know that American-made products are important to our customers. That's why Chester manufactures the majority of its hoists at our two Ohio facilities. We also manufacture many of our other brands' hoists and rigging products here in America as well.

Dating back to 1933, the Buy American Act requires end products for supplies or construction material to be manufactured domestically. For a product to comply with this Act, it is required that more than half the cost of its components is derived from U.S.-made components.

Chester Hoist is proud to comply with the Buy American Act and is happy to supply a Certificate of Compliance upon request.



ABOUT US**A CLOSER LOOK
AT CHESTER HOIST**

The roots of Chester Hoist date back to 1881 when Mr. Hugh Wright started the Wright Hoist Company in Lisbon, Ohio. In 1928, the Wright Hoist Company was sold to the American Chain and Cable Company, today known as ACCO, and later moved to York, Pennsylvania. In 1942, the Wright Brothers returned to Lisbon from York and followed their grandfather into the hoist business by starting the Chester Manufacturing Company. Using a design similar to their grandfather's, they began manufacturing hoists in Lisbon, Ohio, under the Chester brand name.

Since the 1940s, high quality standards and qualification testing have positioned Chester Hoist as a major supplier of hoists to the U.S. Military. In 1954, Chester introduced the Zephyr steel-frame hand chain hoist. Tested and approved to U.S. military specifications, this hoist enabled Chester to become a key hoist supplier to the U.S. Navy. That same year, a spark-resistant version of the Zephyr is introduced, marking Chester's entry into the oil and gas industry.

In 1986, Chester Hoist purchased the Coffing Worm Drive Electric Wire Rope Hoist line from the Duff-Norton Company and began manufacturing the line in Lisbon under the Chester Label. Then, in 1989, Chester Hoist began manufacturing ultra-low headroom electric chain hoists. This line, in addition to its low-headroom wire rope hoists and "Zephyr" low headroom manual hoists, makes Chester the industry leader in close headroom hoists.

Acquired by Columbus McKinnon in 1995, Chester Hoist still produces Zephyr low-headroom manual hoists at its facility in Lisbon, Ohio. In addition to the Zephyr, Chester is known for its specially engineered hoists and trolleys used in a variety of industries.



THE POWER OF INTELLIGENT LIFTING

Columbus McKinnon is one of the most respected and well-known names in the material handling industry. We combine two different yet complimentary areas of expertise – rigging products and hoists – to develop complete floor-to-ceiling lifting systems for even the most unique material handling applications.

Columbus McKinnon designs and manufactures a large portfolio of durable and reliable products for a variety of industries. Our portfolio includes powered and manual hoists, rigging products, below-the-hook attachments, cranes, enclosed track systems and specially engineered products.

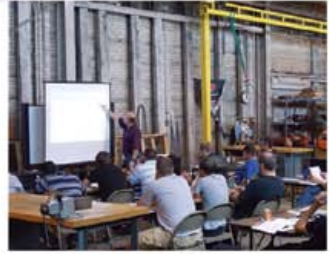

KNOW HOW. KNOW WHY. BE SAFE. GET TRAINED.

Not only is Columbus McKinnon a leader in material handling products, we are also a global leader in providing expertise and training on the proper use and inspection of rigging and overhead lifting equipment. With a range of comprehensive programs and seminars conducted at venues throughout North America, including our hands-on training centers and private companies, our courses include:

- Hoist Maintenance
- Safe Hoisting
- Rigging Gear Inspection
- Crane & Hoist Inspection
- Load Securement
- Crane Operator Training
- Rigging

One of our newest programs, **CMCO University**,™ is a three-day course designed to give attendees an intimate knowledge of our products, the information they'll need to select the right product for the application, and the tools to win in the marketplace.

Classes are available at our state-of-the-art, hands-on training centers, including the **Niagara Training Center** and the **Hoist & Rigging Training Center of Excellence in the Center for Occupational Health and Automobile Manufacturing (COHAM) lab at The Ohio State University**.

Rely on Columbus McKinnon for the products and expertise you need to keep your workforce productive and safe.

