

FIXED STEEL GANTRY CRANE - FHS-2-20

APPROX WEIGHT: 843.95 lbs.
DOES NOT INCLUDE WEIGHT OF POWER OR PACKAGING!!!

*** ANY ADDITIONS, DELETIONS, OR OMISSIONS MUST BE CORRECTED ON THIS DRAWING AS THIS DRAWING WILL BE CONSIDERED ALL INCLUSIVE ***

ALL GRAPHICS PROVIDED ARE FOR REFERENCE ONLY. IF CERTAIN DIMENSIONS ARE CRITICAL PLEASE VERIFY THOSE DIMENSIONS WITH YOUR SALESPERSON

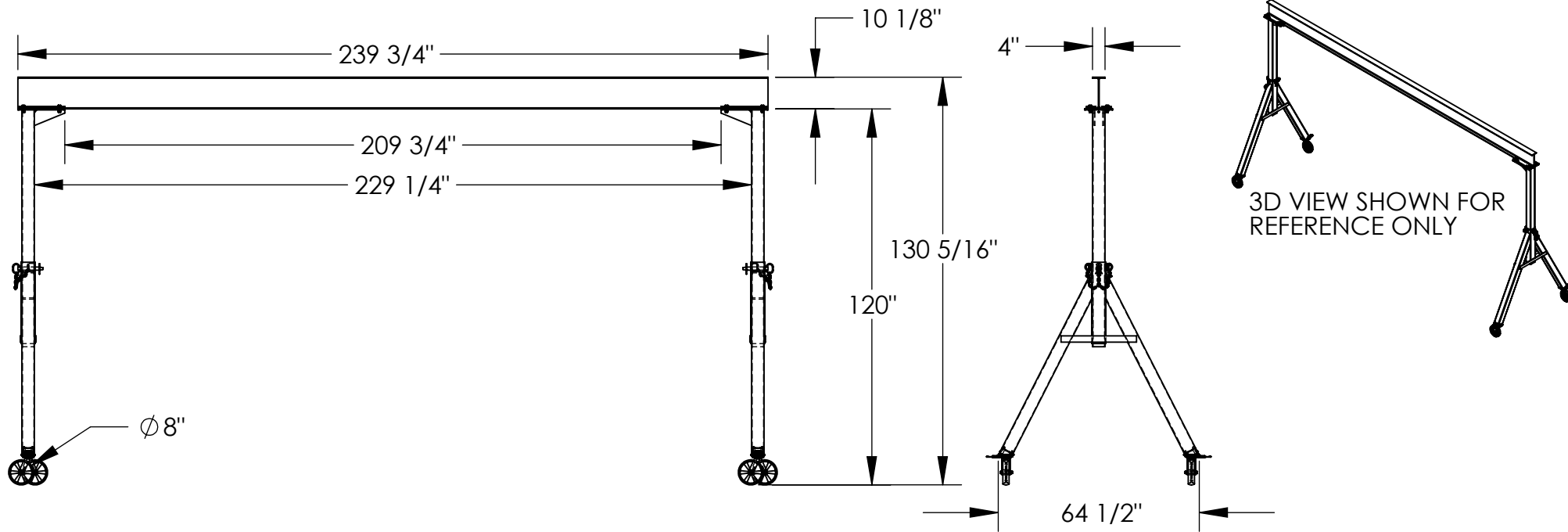

DIMENSION TOLERANCE $\pm 1/4"$

STANDARD FEATURES

MODEL NUMBER IS FHS-2-20
CAPACITY IS 2,000 LBS.
BASE WIDTH IS 64 1/2"
OVERALL HEIGHT IS 130 5/16"
I-BEAM HEIGHT IS 10 1/8"
I-BEAM FLANGE WIDTH IS 4"
OVERALL I-BEAM LENGTH IS 239 3/4"
USABLE I-BEAM LENGTH IS 209 3/4"
UNDER I-BEAM HEIGHT IS 120"
CASTERS: (4) $\varnothing 8"$ X 2" WIDE GLASS FILLED
NYLON SWIVEL CASTERS WITH FOUR LOCKING POSITIONS
DURABLE LIQUID PAINT BLUE FINISH

SPECIAL FEATURES

NONE

APPROVAL

I, THE UNDERSIGNED, AGREE THAT THE PRODUCT AS REPRESENTED SATISFIES DESIGN AND DIMENSION REQUIREMENTS. I ALSO ACKNOWLEDGE MY DUTY TO CONFIRM PRODUCT AND INSTALLATION COMPLIANCE WITH ALL APPLICABLE FEDERAL, STATE AND LOCAL REGULATIONS AND STANDARDS.
UNITS REQUIRING APPROVAL DRAWINGS OR MODIFIED ARE NON-RETURNABLE
[] As drawn [] As marked

Signed: _____ Date: _____

Printed Name: _____

LEAD TIME WILL START UPON RECEIPT OF SIGNED APPROVAL DRAWING

DISTRIBUTOR'S NAME:		P.O.#
VESTIL MANUFACTURING		X
DRAWN BY: MTS	DATE: 08/18/2014	W.O.#
REFERENCE: X	SCALE: 1:48	X
QUOTED LEAD TIME: X	QUOTE #	FILE NAME:
	X	28-007-352