

FORK MOUNTED DRUM CARRIER/ROTATOR - DCR-205-8

APPROX WEIGHT: 150.31 lbs.
 DOES NOT INCLUDE WEIGHT OF POWER OR PACKAGING!!!

*** ANY ADDITIONS, DELETIONS, OR OMISSIONS MUST BE CORRECTED ON THIS DRAWING AS THIS DRAWING WILL BE CONSIDERED ALL INCLUSIVE ***

ALL GRAPHICS PROVIDED ARE FOR REFERENCE ONLY. IF CERTAIN DIMENSIONS ARE CRITICAL PLEASE VERIFY THOSE DIMENSIONS WITH YOUR SALESPERSON

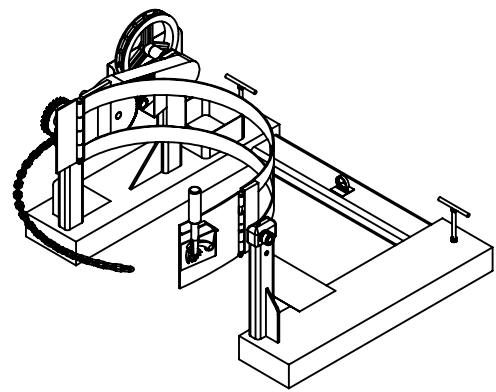
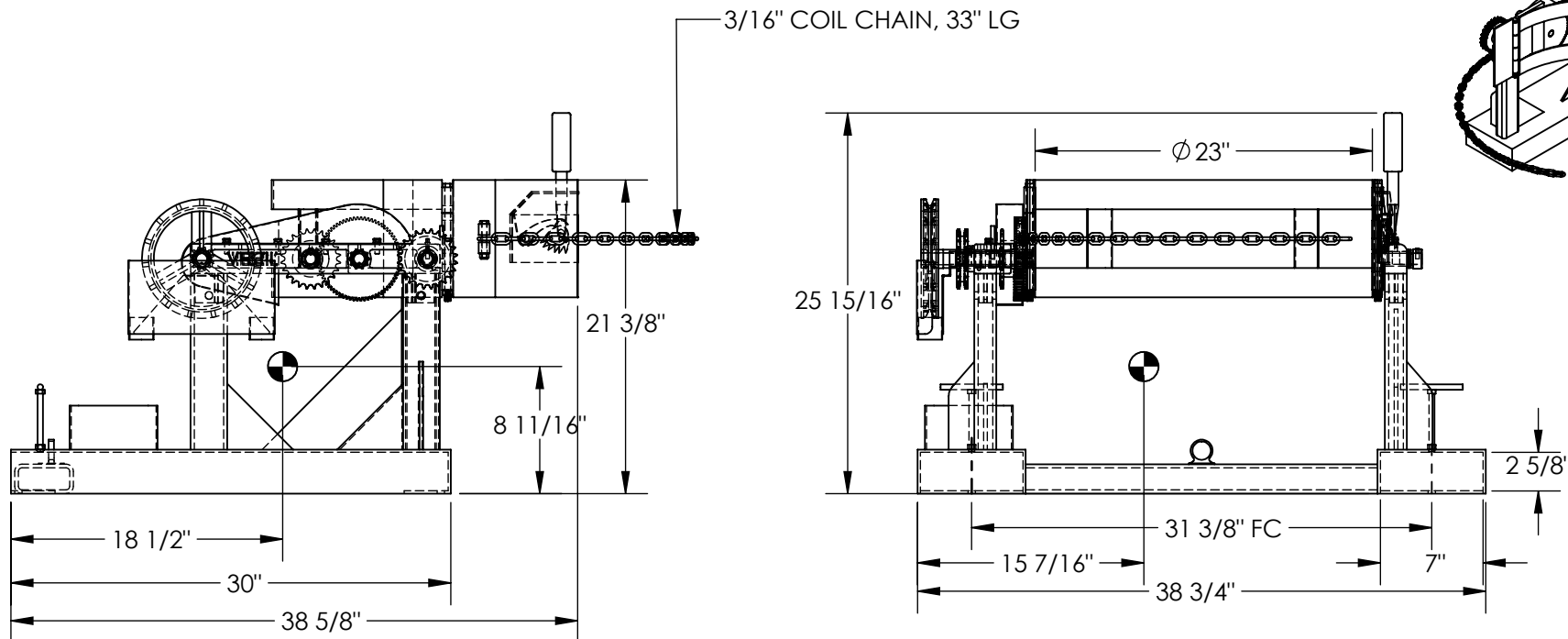

STANDARD FEATURES

- MODEL NUMBER IS DCR-205-8
- OVERALL WIDTH IS 38 3/4"
- OVERALL LENGTH IS 38 5/8"
- OVERALL HEIGHT IS 25 15/16"
- FITS 1- 55 GALLON DRUM
- MAX CAPACITY IS 800 LBS.
- FORK TRUCK RESTRAINT CHAIN LENGTH IS 56" (NOT SHOWN)
- 15' ROTATION PULL CHAIN (NOT SHOWN)
- FORK POCKET CENTER-TO-CENTER IS 31 3/8"
- USABLE FORK POCKET SIZE IS 7" X 2 5/8"
- BUNG WRENCH INCLUDED (NOT SHOWN)
- LOST LOAD IS 151 LBS. (APPROX)
- EFFECTIVE THICKNESS IS FORK LENGTH MINUS 29 3/4"
- FRAME IS TOUGH BAKED IN POWDER COATED YELLOW FINISH
- CRADLE IS TOUGH BAKED IN POWDER COATED BLUE FINISH

NEVER EXCEED LOAD CENTER RATING PER FORK TRUCK MANUFACTURER'S GUIDELINES.

DO NOT USE THIS FORK TRUCK ATTACHMENT IF LOAD WILL EXCEED FORK TRUCK MANUFACTURER'S LOAD CENTER RATING.

SPECIAL FEATURES

NONE

DIMENSION TOLERANCE ± 1/2"

UNITS REQUIRING APPROVAL DRAWINGS OR MODIFIED ARE NON-RETURNABLE

[] As drawn [] As marked

Signed: _____ Date: _____

Printed Name: _____

LEAD TIME WILL START UPON RECEIPT OF SIGNED APPROVAL DRAWING

DISTRIBUTOR'S NAME:		P.O.#
VESTIL MANUFACTURING		X
DRAWN BY: CA		W.O.#
DATE: 08/26/2013		X
REFERENCE: X	SCALE: 1:12	SALES: X
QUOTED LEAD TIME: X	QUOTE #	FILE NAME:
	X	09-007-179