

TNER Series Theatrical Chain Hoists

Unique Features

Standards

Hoist exceeds stringent world standards; complies with German regulation **BGV-D8**. Standard configuration meets CE Declaration.



Pull-Rotor Motor Brake

World's most reliable theatrical hoist brake. Simple design. No brake coil to fail or brake disc to replace. **5 year hoist brake warranty.**



Unique Chain Guide

Provides quiet and smooth guiding of chain into hoist and chain container. Durable, heavy cast iron construction.



Sleek Rounded Body

Rugged aluminum housing; no sharp edges and flexible, soft-grip handles.



Plug and Play Voltage Changer

Quickly change between 208/230V and 460V. Saves valuable time during setup and integration.

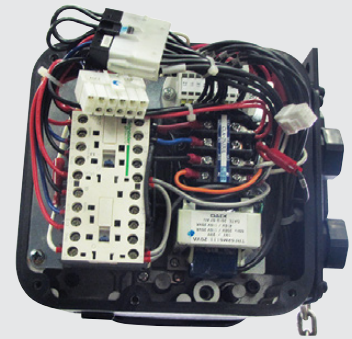

Low Profile Upper/Lower Limit Switches

No adjustment required. Protects hoist and provides maximum travel.



Size and Speed

Designed to fit standard road cases. ½ and 1 Ton—16 fpm; 2 Ton—8 fpm.



Grease-Packed Gearbox

For demanding theatrical applications. Maintenance free.

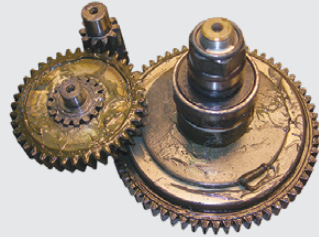

Nickel-Plated Load Chain

Meets DIN and EN 818-7 standards. Optional black chain available.



Friction Clutch

Carbon friction material provides consistent performance over a wide temperature range.



Chain Container

Reversible black canvas chain container needed to meet **BGV-D8** regulations. Also designed with two secure attachment points.



Optional Pendant Control (Pickle)

Red button emergency stop. NEMA 4X, UL/cUL (CSA) listed.



TNER Series Theatrical Chain Hoists

Swivel Top and Bottom Hooks

Both hooks swivel 360 degrees. Ball bearings produce smooth rotation. Heavy duty hook latches standard.

Corrosion Resistant Load Chain

Nickel-plated, DIN chain for superb durability, strength and corrosion resistance.

Flexible Handles

Equipped with two convenient handles for comfortable and easy handling.

Heavy Duty Motor

Increased performance and standard thermal motor protection.

Quiet Load Sheave

Deep groove pockets fully support the load chain during operation. Reduces vibration and chain wear and provides a true vertical lift.

Heat Treated Helical and Spur Gears

Precision machined for long life. Grease lubrication results in quiet and smooth operation. No oil change required.

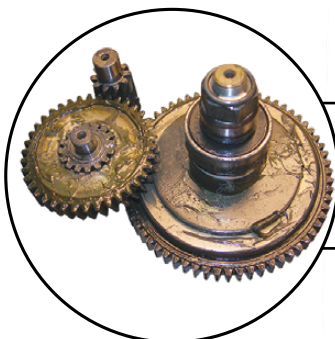
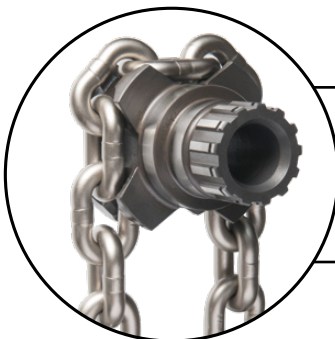

Unique Chain Guide

Provides quiet and smooth guiding of chain. Easily replaced without disassembly of the hoist. Heavy cast iron construction for improved wear versus stamped steel design offered by many manufacturers.

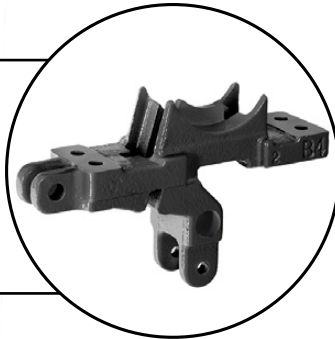

Completely Sealed Body

Suitable for both indoor and outdoor applications, including harsh environments. (Consult Owner's Manual for details.) Gaskets throughout the hoist provide IP55 rating.

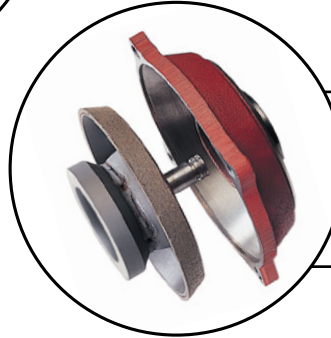

Pull-Rotor Motor Brake

Extremely durable and reliable, this advanced design contains no brake coil to fail like conventional disc brakes.

Long Life Friction Clutch

Protects hoist from damage and prevents overwinding.



Quick Voltage Changer

Change voltage on-the-fly from 208/230V to 460V-3-60. Minimizes prep time from venue to venue. Simple as plug and play.

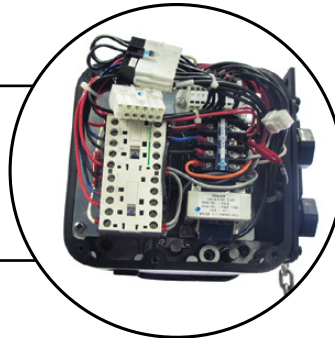

Optional Push Button Pendant (Pickle)

Easy to use, one-handed operation. Rated NEMA 4X, UL/cUL (CSA) listed. Standard control voltage is 110V. Strain relief wire is molded to pendant cord for added support and dependability. Emergency stop on all pendants.



TNER Series Theatrical Chain Hoists



TNER010L

Our TNER Series theatrical chain hoists were designed using the latest technology for handling stage and theatrical equipment. These high quality, low-headroom, full-featured hoists provide reliable performance for use in theaters, concert halls, arenas and studios.

Features

Standards

Hoist exceeds stringent world standards; complies with German regulation BGV-D8. Standard configuration meets CE Declaration.

Pull-Rotor Motor Brake

World's most reliable theatrical hoist brake. Simple design. No brake coil to fail or brake disc to replace. **5 year hoist brake warranty.**

Unique Chain Guide

Provides quiet and smooth guiding of chain into hoist and chain container. Durable, heavy cast iron construction.

Sleek Rounded Body

Rugged aluminum housing; no sharp edges and flexible soft-grip handles.

Plug and Play Voltage Changer

Quickly change between 208/230V and 460V. Saves valuable time during setup and integration.

Low Profile Upper/Lower Limit Switches

No adjustment required. Protects hoist and provides maximum travel.

Size and Speed

Designed to fit standard road cases. ½ and 1 Ton—16 fpm; 2 Ton—8 fpm.

Grease-Packed Gearbox

For demanding theatrical applications. Maintenance free. No oil changes required.

Nickel-Plated Load Chain

Meets DIN and EN 818-7 standards. Optional black chain available.

Friction Clutch

Carbon friction material provides consistent performance over a wide temperature range.

Chain Container

Reversible black canvas chain container needed to meet **BGV-D8** regulations. Also designed with two secure attachment points.

Optional Pendant Control (Pickle)

Red button emergency stop. Nema 4X, UL/cUL (CSA) listed.

Standard Hoist Specifications

Capacity Range

1/2 Ton – 2 Ton

Reconnectable Voltage

208-230/460-3-60

Control Voltage

110V

Duty Cycle*

30 Minutes

Classification*

ASME H3
JS/ISO M3
FEM 1Bm

Ratings

Hoist — IP55
Optional Pendant — NEMA 4X,
UL/cUL (CSA) listed

Chain Container

Standard
Canvas

Standard Lift

60' (other lengths available)

Standard Pendant and Power Supply Cord

2.5' (longer lengths available)

Optional**

Pendant (Pickle)
Pendant Cord
Power Supply Cord
Hubbell, 7-Pin or 14-Pin Connectors
Road Case
Black Load Chain
Bullard® and Shur-Loc® Hooks

*See page 12 for additional information.

**See page 10 for additional information.

HARRINGTON TNER SERIES THEATRICAL CHAIN HOISTS



TNER010L

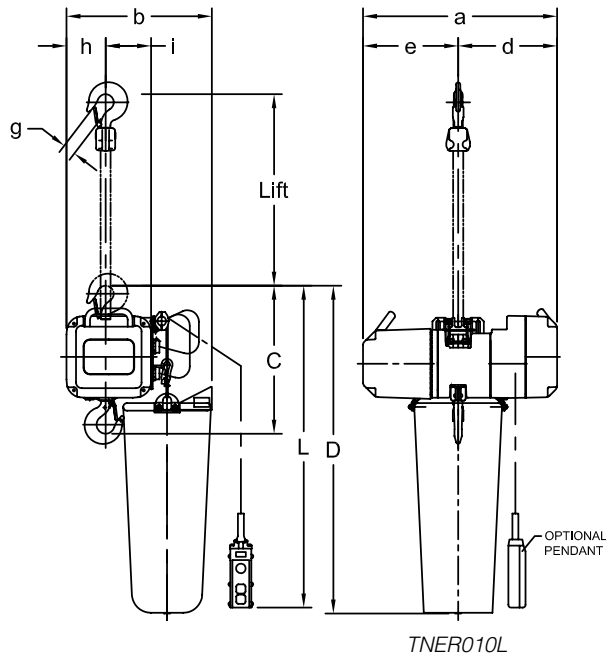

TNER010L

SINGLE SPEED—SPECIFICATIONS

Capacity (Tons)	Product Code	Standard Lift (ft)	Standard Push Button Cord L* (ft)	Lifting Speed (ft/min)	Lifting Motor 3 Phase 60 Hz			Load Chain Diameter (mm) x Chain Fall Lines	Net Weight for 10' Lift (lbs)	Net Weight for 60' Lift (lbs)	Weight for Additional One Foot of Lift (lbs)
					Output (Hp)	Rated Current (amps)					
						@208 - 230V	@460V				
1/2	TNER005L	10 or 60	2.5	16	0.65	3.7	1.9	6.3 x 1	77	104	0.57
1	TNER010L				1.3	5.6	2.8	8.0 x 1	99	146	
1	TNER010S			32	2.4	10.4	5.2		108	155	
2	TNER020L			8	1.3	5.6	2.8		8.0 x 2	126	217
2	TNER020S			16	2.4	10.4	5.2	135		225	1.9

*Pendant (pickle) is optional.

SINGLE SPEED—DIMENSIONS

Capacity (Tons)	Product Code	Headroom C (in)	a (in)	b (in)	d (in)	e (in)	g (in)	h (in)	i (in)	D (in)
1/2	TNER005L	13.2	18.7	14.2	9.6	9.2	0.9	3.9	4.0	35.4
1	TNER010L	16.1	20.0	15.0	10.2	9.8	1.2	4.1	4.7	37.0
1	TNER010S	16.1			8.8	11.2				
2	TNER020L	22.8			10.2	9.8	1.5			48.8
2	TNER020S	22.8			8.8	11.2				