

Lift a Rimmed Steel, Plastic or Fiber Drum with Your Crane

MADE
IN
USA



- Each Model Works with a Range of Drum Sizes (See chart below)
- Capacity: 1000 Lb. (454 kg)

Self adjusting tong-like action automatically grips various common types of closed drums. Slim-profile grippers allow you to lower a drum into an overpack or salvage drum... place 30's into 55's, or 55's into 85's. Handle steel drum, a rimmed plastic drum, or a lever-lock fiber drum.

Drum lid MUST be on and properly secured. **NOTE: Rim must be within 1" of the top of drum to be lifted.** Do not exceed drum manufacturer's packing limit.

Each Morse below-hook drum handler is load tested at the factory at 125% of rated capacity as per American National Standard ASME B30.20, and a load test certificate is supplied.



Use with model 284 Fork Hook

- Engages Under Top Rim
- Place Drum into Salvage Drum



Load an upright drum into a 309 Series Drum Tumbler



Model 92-SS
Stainless Steel 55-Gallon Lifter
Handle drum with 18" to 26"
(45.7 to 66 cm) diameter



Model 92-30
30-Gallon Lifter
Handle drum with 15" to 23"
(38.1 to 58.4 cm) diameter



PailPRO Model 92-5
5-Gallon Pail Lifter
Handle pail 11" to 15"
(27.9 to 38.1 cm) diameter



Load an upright drum onto a 456 Series Hydra-Lift Drum Roller

Model #	Description	For Diameter Range
92	30 to 85 gallon drum lifter	18" to 26" (45.7 to 66 cm)
92M	Spark Resistant 30 to 85 gallon drum lifter	18" to 26" (45.7 to 66 cm)
92-SS	Stainless Steel 30 to 85 gallon drum lifter	18" to 26" (45.7 to 66 cm)
92-30	30 to 55 gallon drum lifter	15" to 23" (38.1 to 58.4 cm)
92-30SS	Stainless Steel 30 to 55 gallon drum lifter	15" to 23" (38.1 to 58.4 cm)
92-5	5 to 15 gallon pail lifter	11" to 15" (27.9 to 38.1 cm)



morsedrums.com



service@morsedrums.com



(315) 437-8475



103 Kuhn Rd.
Syracuse, NY, 13208 USA

Minimum and Maximum Drum Diameter

Model 92, 92M & 92-SS

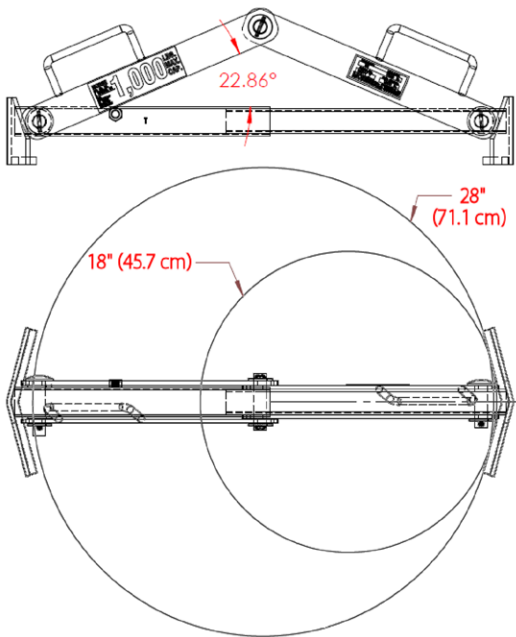

Model # 92-30 & 92-30SS

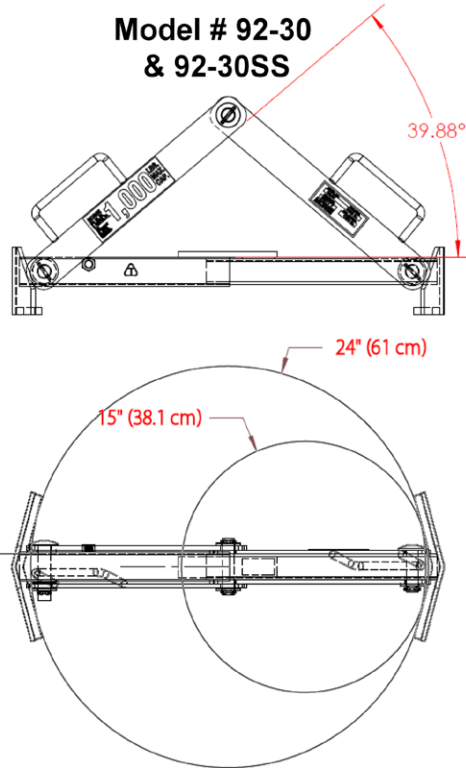

Model # 92-5

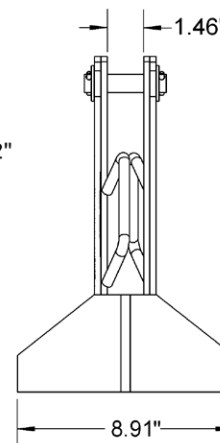
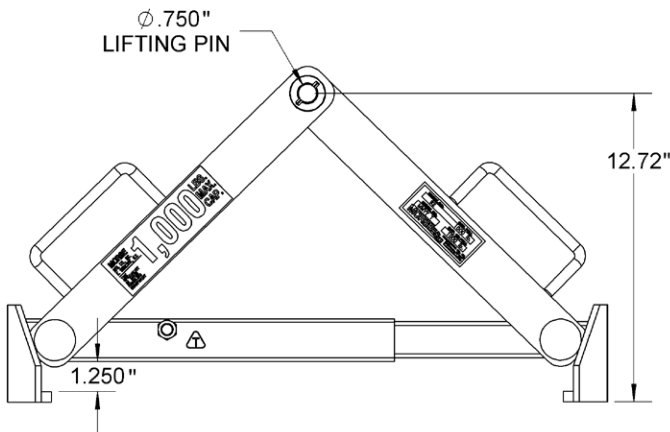
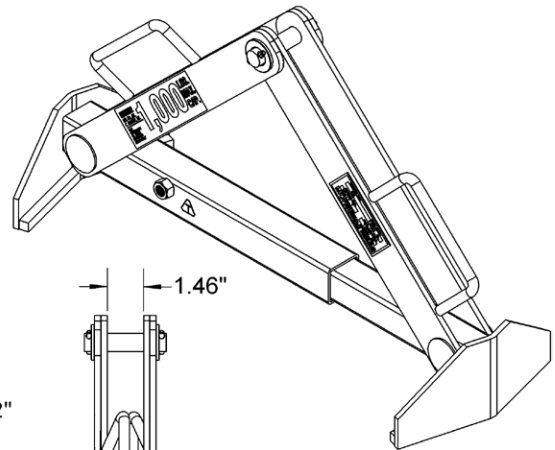
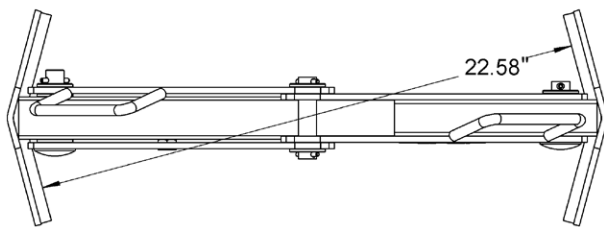
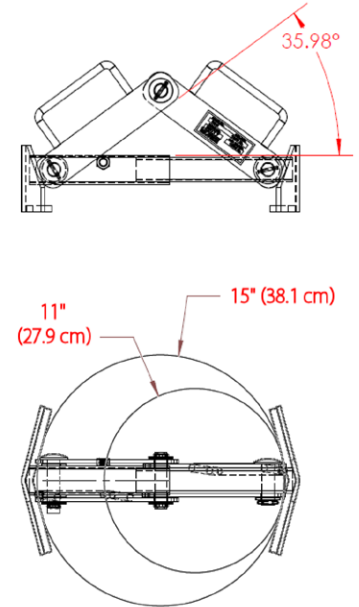

Model 92, 92M or 92-SS Configured for typical 55-gallon (210 liter) steel drum

MADE
IN
USA